

DIASWISS

PRECISION DENTAL INSTRUMENTS

2019



*Dental instruments
and consumables*

All rights reserved

Reproduction, also in part, is only permitted with written authorization by Diaswiss S.A. The general sales and delivery terms of Diaswiss S.A. apply to all offers, orders and shipments. We reserve the right to modify the product range and product designs as well as to deviate from the illustrations, photos and data shown.

Tous droits réservés

La reproduction, même partielle, et copie par quelque procédé que ce soit est permise uniquement avec l'autorisation écrite de Diaswiss S.A. Les conditions générales de Diaswiss S.A. s'appliquent à toutes les offres, ventes et livraisons. Diaswiss réserve le droit de modifier la gamme de produits ainsi que les formes. Des déviations par rapport aux illustrations et aux indications sont possibles.

Alle Rechte vorbehalten

Nachdruck, auch auszugsweise und jede Art von Vervielfältigung sind nur mit schriftlicher Genehmigung der Diaswiss S.A. zulässig. Für sämtliche Angebote, Verkäufe und Lieferungen gelten die allgemeinen Geschäftsbedingungen der Diaswiss S.A. Programm- und Konstruktionsänderungen sowie Abweichungen von den Abbildungen und Angaben bleiben vorbehalten.

Todos los derechos reservados.

Tanto la reimpresión, aunque sea parcial, como cualquier tipo de reproducción sólo están permitidas con previa autorización escrita de Diaswiss S.A. Las condiciones comerciales generales de Diaswiss S.A. se aplican a todas las ofertas, ventas y envíos. Queda reservado el derecho a realizar modificaciones en el programa y en la construcción, así como a las divergencias respecto a las imágenes y los datos.

Tutti i diritti riservati.

La ristampa, anche parziale, e qualsiasi forma di riproduzione sono ammesse esclusivamente su autorizzazione scritta della Diaswiss S.A. Tutte le offerte, le operazioni di vendita e fornitura sono soggette alle condizioni commerciali generali della Diaswiss S.A. Con riserva di eventuali modifiche all'assortimento e alle caratteristiche costruttive, nonché discrepanze rispetto alle immagini e ai dati.

Diaswiss

Precision dental instruments and consumables in Swiss quality.

Diaswiss offers state-of-the art solutions for clinical and dental lab applications that enable the user to work efficiently from a medical, technical and economic perspective. Development and manufacturing of our instruments follows the strictest quality standards, at the same time we provide innovative solutions for new applications and demands.

Our broad product range contains the right instrument for almost any application. The technical specification of the instruments in terms of cutting geometries, crosscuts or diamond coatings is driven strictly by the clinical or technical application needs and/or the material thereby reducing the need for frequent instrument change. We are confident that this will help you deliver outstanding results.

Our modern, certified quality management system ensures a consistently high quality across all product groups. We believe that our modern product range will set a standard for the dental industry. More information is available at

www.diaswiss.ch

Diaswiss

Instruments dentaires de précision et consommables de qualité suisse.

Diaswiss propose des solutions modernes aux problèmes médico-dentaires et techniques. Ces solutions permettent de travailler avec efficacité et rentabilité. Nous développons et fabriquons nos instruments conformément aux critères de qualité les plus rigoureux et proposons des solu-

tions innovantes pour répondre aux exigences les plus pointues.

Vous êtes assurés de trouver dans notre gamme de produits des instruments appropriés pour chaque application. Les caractéristiques de chaque instrument, comme la denture, la géométrie de coupe ou le diamantage, sont étudiés en fonction du matériau. Nous contribuons de cette manière à vous permettre d'obtenir des résultats optimaux sans être obligé de changer souvent d'instrument.

Notre système certifié de gestion de la qualité est le garant d'un niveau de qualité élevé. Nous avons étendu et renouvelé notre gamme, et sommes convaincus qu'elle répondra à toutes les exigences actuelles. Pour plus d'informations, consultez notre site

www.diaswiss.ch

Diaswiss

Dentale Präzisionswerkzeuge und Verbrauchsartikel in Schweizer Qualität.

Diaswiss bietet moderne Lösungen für alle zahnmedizinischen und zahntechnischen Anforderungen und ermöglicht so ein effizientes und wirtschaftliches Arbeiten. Die Entwicklung und Herstellung unserer Instrumente erfolgt nach strengsten Qualitätsmaßstäben, zudem bieten wir für neue Anforderungen innovative Lösungen.

Das breite Sortiment stellt sicher, dass für jede Anwendung ein geeignetes Instrument vorhanden ist, wobei die einzelnen Instrumente hinsichtlich Spezifikation wie Verzahnung, Schneidengeometrie oder Diamantierung auf die jeweiligen Werkstoffe ausgelegt sind. Auf diese Weise tragen wir dazu bei, dass Sie

beste Arbeitsergebnisse erzielen und gleichzeitig einen häufigen Instrumentenwechsel vermeiden können.

Unser zertifiziertes Qualitätsmanagement sichert einen konstant hohen Qualitätsstandard über alle Produktbereiche hinweg. Wir sind zuversichtlich, dass unser modernes Produktsortiment Maßstäbe setzen wird. Weitere Informationen sind auch über unsere Homepage erhältlich unter:

www.diaswiss.ch

Diaswiss

Herramientas dentales de precisión y artículos consumibles de calidad suiza.

Diaswiss ofrece soluciones modernas para los problemas odontológicos y protésicos con las que usted podrá trabajar de un modo eficaz y rentable. Tanto el desarrollo como la fabricación de nuestros instrumentos se realizan conforme a las normas de calidad más exigentes. Además, también ofrecemos soluciones innovadoras para nuevas aplicaciones.

Nuestra amplia gama de productos garantiza la disponibilidad del instrumental adecuado para cada indicación. En este sentido, cada uno de los instrumentos está diseñado para el correspondiente material en lo que a las características especificadas se refiere, como el dentado, la geometría de los filos y el diamantado. De este modo le ayudamos a conseguir los mejores resultados a la vez que le evitamos el cambio frecuente del instrumental.

Nuestra gestión de calidad moderna y certificada garantiza un elevado estándar de calidad constante para todos nuestros pro-

ductos. Estamos seguros de que nuestra gama de productos renovada y ampliada establecerá nuevos estándares. Encontrará más información en nuestra página web:

www.diaswiss.ch

Diaswiss

Strumenti dentali di precisione e articoli di consumo di qualità svizzera.

Per applicazioni odontoiatriche e odontotecniche di qualsiasi livello Diaswiss offre soluzioni moderne che consentono di operare in modo efficiente ed economico. Lo sviluppo e la lavorazione dei nostri strumenti avvengono secondo i più rigorosi standard qualitativi. Allo stesso tempo Diaswiss offre anche soluzioni innovative per soddisfare nuovi tipi di esigenze.

L'ampio assortimento garantisce la disponibilità del giusto strumentario per ogni tipo di applicazione ed offre strumenti idonei per varie tipologie di materiali in base a specifiche quali taglio, geometria di taglio o diamantatura. Contribuiamo in tal modo al raggiungimento del miglior risultato possibile e alla riduzione di una frequente sostituzione dello strumento.

Il nostro moderno sistema di gestione della qualità è certificato e garantisce un livello di qualità costantemente elevato per tutta la gamma dei nostri prodotti. Siamo certi che il nostro assortimento di prodotti rinnovato e ampliato imporrà nuovi standard. Per ulteriori informazioni consultare il nostro sito all'indirizzo

www.diaswiss.ch

SQS **EC-Certificate**

SQS as a conformity assessment body identification number 1250 herewith certifies the company

Diaswiss SA
Instruments et fournitures dentaires
Rte de St-Cergue 293
1260 Nyon
Switzerland

the use of a quality assurance system in its manufacturing and distribution which fulfills the requirements set out in:

ANNEX V **Directive 93/42/EEC**

This approval is based on the result of the report dated April 9, 2018.

The scope of validity covers the products
Class IIa
Diamond and carbide instruments,
Bone cutters (steel and carbide),
Dental polishers,
Ceramic burs,
Endodontic instruments

The following CE label can be applied to the products mentioned in this certificate
CE 1250

A condition for the validity of this certificate is a regular examination in accordance with Annex V.4 of the Directive 93/42/EEC

Validity 20.04.2018–19.04.2021
Issue 20.04.2018

Reg. no. 32850
Approved PV Medical 20.04.2018

F. Müller
F. Müller, CEO SQS

D. Tabbou
D. Tabbou, Medical Responsible

Swiss Association for Quality and Management Systems SQS
Bermstrasse 103, 3052 Zollikofen, Switzerland

Swiss Made

Partner of **IQNet**

IQNet
THE INTERNATIONAL CERTIFICATION NETWORK
CERTIFICATE

SQS has issued an IQNet recognized certificate that the organization:

Diaswiss SA
Instruments et fournitures dentaires
Rte de St-Cergue 293
1260 Nyon
Switzerland

has implemented and maintains a
Management System
for the following scope(s):
Dental Instruments

which fulfills the requirements of the following standard(s):
EN ISO 13485:2016 Medical devices – Quality Management System

Issued on: 2018-04-20
Expires on: 2021-04-19

This attestation is directly linked to the IQNet Partner's original certificate and shall not be used as a stand-alone document

Registration Number: CH- 23961

IQNet *Alex Stoichitoiu* *F. Müller* **SQS**
Alex Stoichitoiu, President of IQNet Felix Müller, CEO SQS

IQNet Partners:
AENOR Spain AFNOR Certification France ANCCER Portugal CCC Cyprus CIBQ Italy
CQC China CQM China CQS Czech Republic Cto Cert Croatia DQS Holding GmbH Germany FGV Brazil
FONDQWEMA Venezuela IZOTEC Colombia Inspire Certification by Finland INTECO Costa Rica
IRAM Argentina IQA Japan IFS Korea IIRTEC Greece MERT Industry Nerts AS Norway NSAI Ireland
NYTE-SIGC Mexico QCS Poland Q-STAR Austria Austria RIF Russia SII Israel SIB Slovenia
SIRIM QAS International Malaysia SQS-Switzerland SRIAC Romania TISI Switzerland TUV SUD TUVQSS Serbia
IQNet is represented in the USA by: AFNOR Certification, CIBQ, DQS Holding GmbH and NSAI Inc.

* The list of IQNet partners is valid at the time of issue of this certificate. Updated information is available under www.iqnet-certification.com

SQS **Certificate**

SQS herewith certifies that the company named below has a management system which meets the requirements of the standard specified below.

Diaswiss SA
Instruments et fournitures dentaires
Rte de St-Cergue 293
1260 Nyon
Switzerland

Scope of certification
Whole company

Field of activity
Dental Instruments

Normative base
EN ISO 13485:2016 Medical devices – Quality Management System

Validity 20.04.2018–19.04.2021
Issue 20.04.2018

Reg. no. 23961

X. Edelmann
X. Edelmann, President SQS

F. Müller
F. Müller, CEO SQS

Swiss Association for Quality and Management Systems SQS
Bermstrasse 103, 3052 Zollikofen, Switzerland

Swiss Made

Partner of **IQNet**

Dentistry Cabinet dentaire Zahnarzt Clinica dental Studio	6 - 76
Diamond instruments Instruments diamantés Diamantwerkzeuge Instrumentos diamantados Strumenti diamantati	8 - 43
Carbide instruments Fraises en carbure de tungstène Hartmetallwerkzeuge Fresas en carburo de tungsteno Strumenti in carburo di tungsteno	44 - 55
Polishers Polissoirs Polierer Pulidores Gommini	56 - 62
Surgery Chirurgie Chirurgie Cirugia Strumenti chirurgici	63 - 68
Endodontic instruments Instruments endodontiques Endodontische Instrumente Instrumentos de endodoncia Strumenti canalari ENDO	69 - 72
Accessories Divers Sonstige Instrumente Accesorios Accessori	73
Disinfection and cleaning Désinfection et nettoyage Desinfektion und Reinigung Desinfección y limpieza Disinfezione e pulizia	74 - 75
Pictograms and E-Labeling Pictogrammes et étiquetage électronique Piktogramme und E-Labeling Pictogramas y E-Labeling Pittogramme ed E-Labeling	76
Dental lab Laboratoire Labor Laboratorio dental Laboratorio	78 - 162
Carbide instruments Fraises en carbure Hartmetallinstrumente Fresas en carburo de tungsteno Frese in carburo di tungsteno	78 - 99
Electroplated diamonds Instruments diamantés galvaniques Galvanische Diamanten Instrumentos diamantados galvánicos Strumenti diamantati galvanizzati	100 - 109
Sintered diamonds Instruments diamantés dans la masse Sinterdiamanten Instrumentos de diamante macizo Strumenti diamantati sinterizzati	110 - 117
Discs Disques Scheiben Discos Dischi	118 - 129
Zirconia tools Outils pour le zircon Zirkonwerkzeuge Instrumentos para zirconio Strumenti per zirconia	130 - 138
Polishers Polissoirs Polierer Pulidores Gommini	139 - 147
Tool Kits Sets de travail Bearbeitungssets Sets de elaboración Set di rifinitura	148 - 151
Consumables Consommables Verbrauchsartikel Consumibles Articoli di consumo	152 - 160
Accessories Divers Sonstige Instrumente Accesorios Accessori	161 - 162
Index Index Index Índice Indice	163 - 167

Shank information | Longueurs de tiges | Schaftlängen | Longitudes de vástago | Lunghezza del gambo

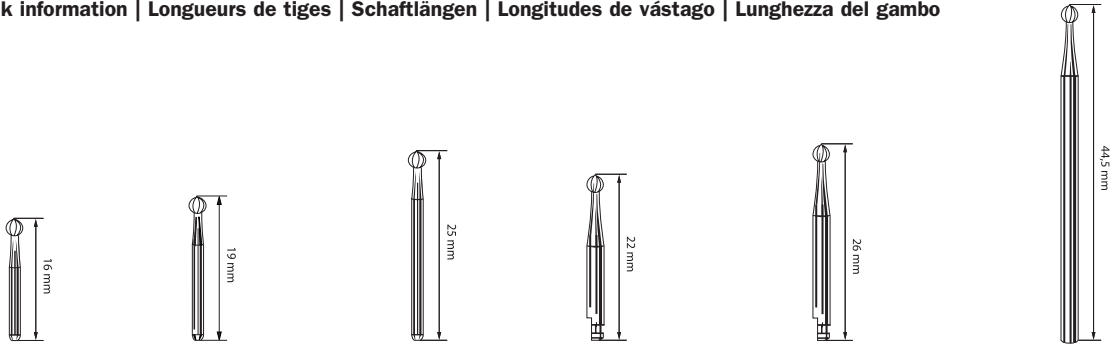

ISO 313 FG short	ISO 314 FG standard	ISO 316 FG XL	ISO 204 right angle	ISO 205 right angle L	ISO 104 HP hand piece
ISO 313 FG court	ISO 314 FG standard	ISO 316 FG XL	ISO 204 contre-angle	ISO 205 contre-angle L	ISO 104 HP pièce à main
ISO 313 FG kurz	ISO 314 FG Standard	ISO 316 FG XL	ISO 204 Winkelstück	ISO 205 Winkelstück L	ISO 104 HP Handstück
ISO 313 FG corto	ISO 314 FG estándar	ISO 316 FG XL	ISO 204 Contraángulo	ISO 205 Contraángulo L	ISO 104 HP pieza de mano
ISO 313 FG corto	ISO 314 FG standard	ISO 316 FG XL	ISO 204 contrangolo	ISO 205 contrangolo L	ISO 104 HP manipolo

Usage symbols | Conseils d'utilisation | Anwendungssymbole | Propuesta de aplicación | Consigli d'uso



Root treatment
Traitement canalaire
Wurzelbehandlung
Tratamiento endodóntico
Per la cura della radice



Crown cutter
Coupe couronnes
Kronentrenner
Cortador de coronas
Tagliacorone



Microprep
Microprep
Minimal invasiv
Minimamente invasivo
Minimale invasivo



Veneers
Facettes
Veneers
Carillas
Faccette



Trepanation
Trépaner
Trepanieren
Trepanar
Trepanare



Inlay preparation
Préparation d'inlay
Inlaypräparation
Preparación de inlay
Preparazione di inlay



Depth marker
Marqueurs de profondeur
Tiefenmarkierung
Marcadores de profundidad
Incisori di profondità



Orthodontics
Orthodontie
KFO
Ortodoncia
Ortodonzia



Fillings
Travail sur obturation
Bearbeiten von Füllungen
Trabajar rellenos
Per la otturazione



Cavity preparation
Préparation de cavités
Kavitätenpräparation
Preparación de cavidades
Preparazione di cavità



Crown preparation
Préparation de couronnes
Kronenpräparation
Preparación de coronas
Preparazione di corone



Prophylaxis
Prophylaxie
Prophylaxe
Profilaxis
Profilassi

ISO codification

The ISO codification consists of 15 digits in 5 groups:

Code ISO

Le code ISO est composé de 15 chiffres répartis en cinq groupes :

ISO-Nummernaufbau

Die ISO-Kodifizierung besteht aus 15 Ziffern, welche in 5 Teilblöcke eingeteilt sind:

Composición del número ISO

La codificación ISO se compone de 15 cifras, divididas en 5 bloques:

Struttura del numero ISO

La codifica ISO è costituita da 15 cifre, suddivise in 5 blocchi:

806

314

001

524

012

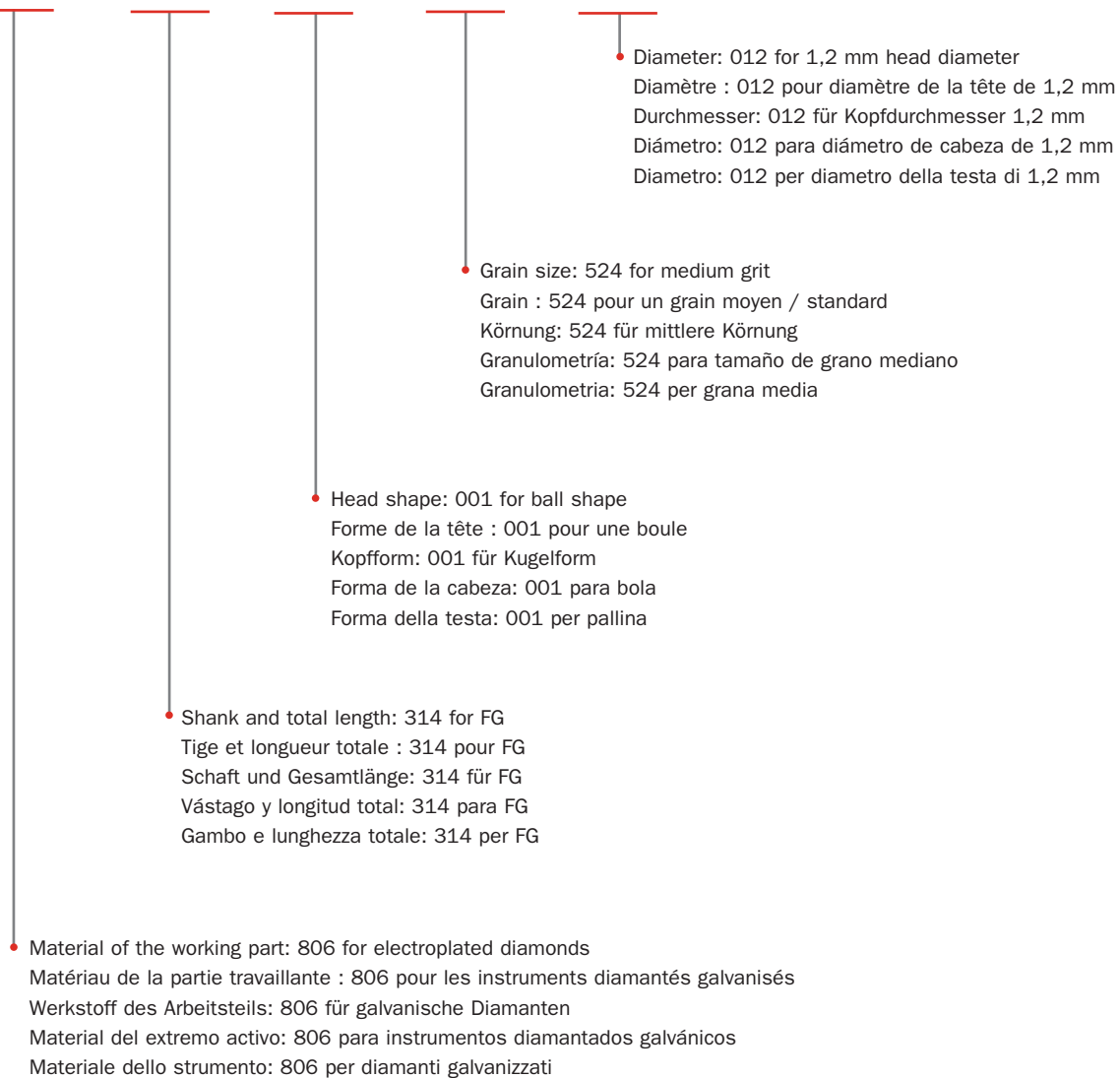

Diamond instruments

Diaswiss diamond instruments are manufactured in a unique quality with an extremely homogeneous and dense diamond coating. They therefore have outstanding durability and economic efficiency. The choice of specially selected all-natural diamonds ensures a superb cutting efficiency and a fast, efficient and patient-friendly treatment.

All Diaswiss diamonds undergo a multi-layer diamond coating with individually controlled embedding. This complex production process is necessary to sustain a quality which meets your and our quality expectations.

The breadth of our diamond range ensures that you will find all the tools you need for cavity and crown preparation as well as for veneers or any other application.

Order-No

You will find the order number in each product segment, please use this order number plus the required diameter. Alternatively, you may also use the ISO-number for the shape plus desired grit and diameter.

Packaging

Diaswiss diamonds are packed as 6 pcs.

Maximum recommended speed FG

Head diameter up to 023	300.000 rpm
Head diameter up to 031	160.000 rpm
Head diameter up to 045	120.000 rpm
Head diameter > 045	90.000 rpm

Maximum recommended speed RA

-30.000 rpm

Instruments diamantés

Diaswiss vous propose des instruments diamantés de qualité incomparable. Ils se caractérisent par une répartition extrêmement homogène et dense des cristaux de diamant, à laquelle ils doivent leur longévité supérieure à la moyenne. L'utilisation de diamants naturels sélectionnés garantit une excellente capacité de coupe. Elle permet en outre de travailler rapidement et sans inconfort pour le patient.

Les instruments Diaswiss sont revêtus de plusieurs couches de cristaux de diamants à sertissage multiple. Ce processus de fabrication complexe est nécessaire pour obtenir une qualité homogène à la hauteur de nos exigences et des vôtres.

Les instruments que nous fabriquons sont disponibles dans de nombreuses formes universelles, qui couvrent toutes les applications, de la préparation des cavités à celle des facettes, en passant par la préparation des moignons pour les couronnes, et bien d'autres encore.

Référence

La référence est indiquée pour chaque article en anglais («Order-No.»). Veuillez indiquer cette référence avec le diamètre lors de la commande. Vous pouvez également indiquer dans votre commande le code ISO de la forme de la tête, le grain ainsi que diamètre.

Conditionnement

Les instruments diamantés FG Diaswiss sont conditionnés par 6 pièces.

Vitesses recommandées pour les instruments diamantés FG:

Diamètre de la tête jusqu'à 023	300'000 tpm
Diamètre de la tête jusqu'à 031	160'000 tpm
Diamètre de la tête jusqu'à 045	120'000 tpm
Diamètre de la tête > 045	90'000 tpm

Vitesse recommandée pour les instruments diamantés RA:

-30'000 tpm

Diamantwerkzeuge

Diaswiss bietet Ihnen Diamantwerkzeuge in einzigartiger Qualität an. Unsere Werkzeuge zeichnen sich durch eine extrem homogene und dichte Diamantbeschichtung aus, die überdurchschnittlich hohe Standzeiten ermöglicht. Die Verwendung von besonders ausgesuchten Naturdiamanten sichert eine hohe Schneidfreudigkeit und ein schnelles, patientenfreundliches Arbeiten.

Die Diaswiss Diamanten sind mehrfach beschichtet und eingebettet, dieser aufwändige Produktionsprozess ist jedoch notwendig, um eine konsistente Qualität zu garantieren, die höchsten Ansprüchen genügt.

Die Vielfalt der von uns hergestellten Formen deckt alle Anwendungen von der Kavitätenpräparation über die Kronenstumpfpräparation bis zur Veneerpräparation und vielen anderen mehr ab.

Bestellnummer

Die Bestellnummer ist als „Order-No.“ bei jedem Artikel angegeben, bitte verwenden Sie diese Bestellnummern inkl. der Durchmesserangabe. Alternativ können Sie unter Angabe der ISO-Kopfform, Körnung und Durchmesser bestellen.

Verpackung

Diaswiss FG Diamanten werden zu 6 Stück verpackt.

Maximale Drehzahlen für FG Diamanten:

Kopfdurchmesser bis 023	300.000 UpM
Kopfdurchmesser bis 031	160.000 UpM
Kopfdurchmesser bis 045	120.000 UpM
Kopfdurchmesser > 045	90.000 UpM

Maximale Drehzahl für WST Diamanten:

-30.000 UpM



Multiple coating and individually controlled embedding

Diamantage et sertissage optimale

Ideale Mehrfachdiamantbeschichtung und Einbettung

Revestimiento e incrustación optima de los diamantes

Rivestimento e deposizione ideale

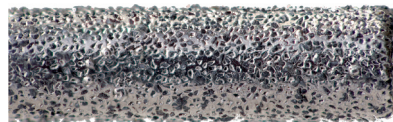

Embedding too deep, diamonds are covered and do not cut

Sertissage trop profond, les diamants ne sont pas assez dégagés

Zu tiefe Einbettung, Diamanten liegen nicht genügend frei

Una incrustración demasiado profunda hace que los cristales de diamante no estén suficientemente expuestos

Con una deposizione troppo profonda le particelle di diamante non sono sufficientemente libere



Embedding too shallow, diamonds break off too fast

Sertissage trop superficiel, les diamants sont dégagés et se cassent

Zu flache Einbettung, Diamanten liegen frei und brechen weg

Una incrustración demasiado superficial hace que los cristales de diamante estén expuestos y se rompan

Con una deposizione troppo superficiale le particelle di diamante sono libere e si staccano

Instrumentos diamantados

Diaswiss le ofrece instrumentos diamantados de calidad exclusiva. Nuestras herramientas destacan por su revestimiento diamantado extremadamente homogéneo y compacto, por eso su vida útil es muy superior a la media. El uso de diamantes naturales seleccionados garantiza un alto rendimiento de corte y un trabajo rápido y cómodo para el paciente.

Los instrumentos diamantados Diaswiss están revestidos e incrustados varias veces. Este complejo proceso de fabricación es necesario para satisfacer su exigencia de una calidad elevada y consistente, y la nuestra también.

La diversidad de las formas de uso universal que fabricamos cubre todas las indicaciones; desde la preparación de las cavidades y de muñones de coronas, hasta la preparación de fundas y mucho más.

Número de pedido

El número de pedido aparece indicado en todos los artículos como "Order-No.". Por favor, utilice este número junto con la indicación del diámetro. Alternativamente puede hacer su pedido indicando la forma de la cabeza ISO, la granulometría y el diámetro.

Envase

Los instrumentos diamantados FG de Diaswiss se suministran en envases de 6 unidades.

Velocidad máxima para los instrumentos diamantados FG:

Diámetro de la cabeza hasta 023	300.000 rpm
Diámetro de la cabeza hasta 031	160.000 rpm
Diámetro de la cabeza hasta 045	120.000 rpm
Diámetro de la cabeza > 045	90.000 rpm

Velocidad máxima para los instrumentos diamantados CA:

-30.000 rpm

Strumenti diamantati

Diaswiss offre strumenti diamantati ad alta qualità. I nostri strumenti si distinguono per un rivestimento diamantato di elevata uniformità e spessore, che consente una durata utile superiore alla media. L'utilizzo di diamanti naturali particolarmente ricercati garantisce un'elevata efficienza di taglio e una rapida lavorazione confortevole per il paziente.

Gli strumenti diamantati Diaswiss sono sottoposti ad un processo produttivo multiplo di rivestimento e deposizione che, pur essendo dispendioso, è necessario per garantire una qualità coerente e conforme ai nostri e ai vostri requisiti.

La molteplicità di forme d'uso universale da noi prodotte copre tutti i settori di applicazione, dalla preparazione di cavità alla preparazione di monconi per corone, fino alla realizzazione di faccette.

Numero d'ordine

Il numero d'ordine è indicato con "Order-No." per ogni articolo. Per ordinazioni si prega di utilizzare questo numero più l'indicazione del diametro. In alternativa è possibile effettuare ordini indicando la forma della testa ISO, la granulometria e il diametro.

Confezione

Gli strumenti diamantati FG Diaswiss sono in confezioni da 6 pezzi.

Velocità massime per gli strumenti diamantati FG:

Diámetro testa fino a 023	300.000 giri/min
Diámetro testa fino a 031	160.000 giri/min
Diámetro testa fino a 045	120.000 giri/min
Diámetro testa > 045	90.000 giri/min

Velocità massima per gli strumenti diamantati CA:

-30.000 giri/min

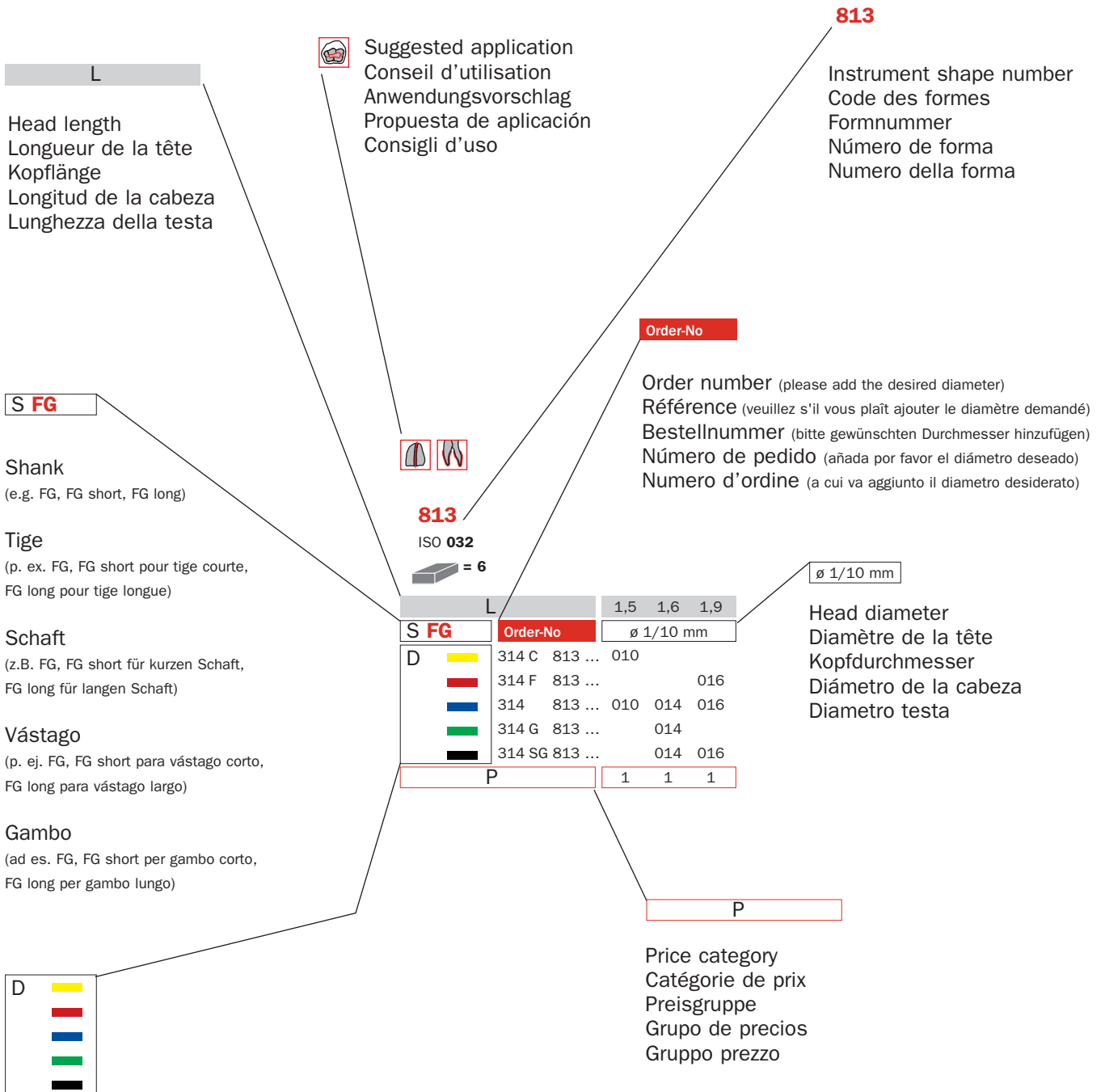

Diamond coating

Yellow (C): superfine ISO 504; Red (F): fine ISO 514; Blue: medium (standard) ISO 524; Green (G): coarse ISO 534; Black (SG): supercoarse ISO 544

Diamantage

Jaune (C): superfin ISO 504; Rouge (F): fin ISO 514; Bleu: moyen (standard) ISO 524; Vert (G): gros ISO 534; Noir (SG): supergros ISO 544

Diamantierung

Gelb (C): superfein ISO 504; Rot (F): fein ISO 514; Blau: mittel (standard) ISO 524; Grün (G): grob ISO 534; Schwarz (SG): supergrob ISO 544

Diamantado

Amarillo (C): superfino ISO 504; Rojo (F): fino ISO 514; Azul: mediano (estándar) ISO 524; Verde (G): grueso ISO 534; Negro (SG): supergrueso ISO 544

Diamantatura

Giallo (C): superfine ISO 504; Rosso (F): fine ISO 514; Blu: media (standard) ISO 524; Verde (G): grossa ISO 534; Nero (SG): supergrossa ISO 544

FG and RA diamonds

Fraises diamantées FG et RA

FG und WST Diamanten

Fresas diamantadas FG y CA

Frese diamantate FG e CA



801

ISO 001

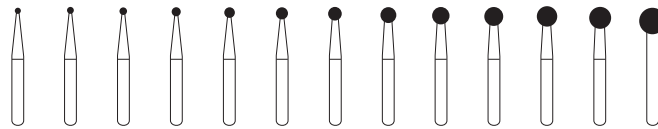

L		-												
S FG	Order-No	ø 1/10 mm												
D	314 C 801 ...					014	016	018	021	023	025	027	029	035
	314 F 801 ...	008		010	012	014	016	018	021	023	025	027	029	035
	314 801 ...	008	009	010	012	014	016	018	021	023	025	027	029	035
	314 G 801 ...	008	009	010	012	014	016	018	021	023	025	027	029	035
	314 SG 801 ...			010	012	014	016	018	021	023	025	027	029	035
P		1	1	1	1	1	1	1	2	2	2	2	3	4
S FGshort	Order-No	ø 1/10 mm												
D	313 801 ...		009	010	012	014	016	018						
P			1	1	1	1	1	1						
S RA	Order-No	ø 1/10 mm												
D	204 801 ...			010	012	014	016	018		023			029	
P				11	11	11	11	11		12			14	



801 L

ISO 697



L		-						
S FG	Order-No	ø 1/10 mm						
D	314 F 801L ...	012	014	016			023	
	314 801L ...	012	014	016	018	021	023	027
	314 G 801L ...	012	014	016	018	021	023	027
	314 SG 801L ...			014	016			
P		2	2	2	2	3	3	4



802

ISO 002

= 6

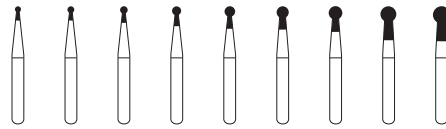

L		2,5	2,5	2,5	3,0	3,0	3,0	3,5	4,0	4,5
S FG	Order-No	ø 1/10 mm								
D	314 F 802 ...				012	014				
	314 802 ...	008	009	010	012	014	016	018	021	023
	314 G 802 ...			010	012	014	016	018		
	314 SG 802 ...					014	016	018		
P		1	1	1	1	1	1	2	2	
S FGshort	Order-No	ø 1/10 mm								
D	313 802 ...		009		012		016			023
P			1		1		1			2
L		4,0								
S RA	Order-No	ø 1/10 mm								
D	204 802 ...	018								
P		11								



802 L

ISO 494

= 6

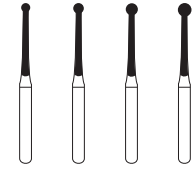

L		11	11	11	11
S FG	Order-No	ø 1/10 mm			
D	314 802L ...	012	014	016	018
	314 G 802L ...	012	014	016	018
P		2	2	2	2



805

ISO 010

= 6



L		1,0	1,0	1,5	1,5	1,5	2,0	2,0	2,0
S FG	Order-No	ø 1/10 mm							
D	314 F 805 ...		010		014		018		
	314 805 ...	009	010	012	014	016	018	021	023
	314 G 805 ...		010	012	014	016	018		
	314 SG 805 ...				014	016	018		
P		1	1	1	1	1	2	2	
S FGshort	Order-No	ø 1/10 mm							
D	313 805 ...		010	012		016			
P			1	1		1			
L		2,0 2,5 3,0							
S RA	Order-No	ø 1/10 mm							
D	204 805 ...		012	014	016				
P			11	11	11				



806

ISO 019

= 6



L		2,2	3,0	3,0	3,0	3,2	4,0
S FG	Order-No	ø 1/10 mm					
D	314 C 806 ...		012				
	314 806 ...	010	012	014	016	018	023
	314 G 806 ...	010	012	014	016	018	
	314 SG 806 ...			014			
P		1	1	1	1	1	2
S FGshort	Order-No	ø 1/10 mm					
D	313 806 ...	010	012				
P		1	1				



807

ISO 225

= 6

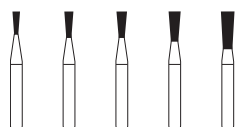

L		3,0	3,5	3,5	4,0	5,0
S FG	Order-No	ø 1/10 mm				
D	314 807 ...	010	012	014	016	018
	314 G 807 ...		012	014	016	018
	314 SG 807 ...		012			
P		1	1	1	1	1
L		4,0				
S RA	Order-No	ø 1/10 mm				
D	204 807 ...	016				
P		11				



810

ISO 021

= 6



L		2,0
S RA	Order-No	ø 1/10 mm
D	204 810 ...	040
P		14



811

ISO 038

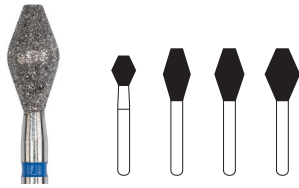

L		4,0	7,0	7,0	7,0
S FG	Order-No	ø 1/10 mm			
D	314 811 ...	033	037	040	
	314 G 811 ...	033		040	047
	314 SG 811 ...	033	037		
P		4	4	4	4



813

ISO 032



L		1,5	1,5	1,8
S FG	Order-No	ø 1/10 mm		
D	314 F 813 ...	014		
	314 813 ...	010	014	016
	314 G 813 ...	014 016		
P		1	1	1



813L

ISO 032



L		3,0	3,0
S FG	Order-No	ø 1/10 mm	
D	314 813L...	014	016
P		1	1



815

ISO 040

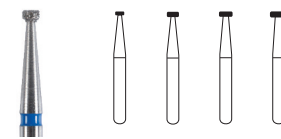

L		1,0	1,0	1,0	1,0
S FG	Order-No	ø 1/10 mm			
D	314 815 ...	012	016	018	023
P		1	1	1	2



817

ISO 041

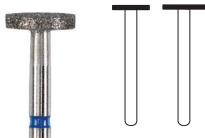

L		1,0	1,0
S FG	Order-No	ø 1/10 mm	
D	314 817 ...	050	057
	314 G 817 ...	050	057
P		4	4



818

ISO 041

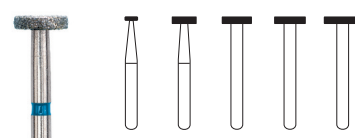

L		1,0	1,0	1,0	1,0	1,0
S FG	Order-No	ø 1/10 mm				
D	314 818 ...	018	033	040	042	050
	314 G 818 ...	033 040 042				
P		1	4	4	4	4
L		1,0				
S RA	Order-No	ø 1/10 mm				
D	204 818 ...	040				
P		14				



820

ISO 043

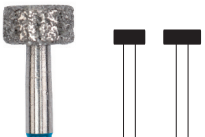

L		1,5	2,0
S FG	Order-No	ø 1/10 mm	
D	314 820 ...	042	050
P		4	4



822

ISO 237

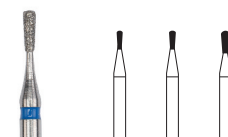

L		2,5	2,5	3,0
S FG	Order-No	ø 1/10 mm		
D	314 822 ...	008	009	012
	314 G 822 ...	008	009	012
P		1	1	1



825

ISO 304

= 6



L		1,0	1,0	1,5
S FG	Order-No	ø 1/10 mm		
D	314 825 ...	018	025	040
P		1	2	4



826

ISO 310

= 6



L		3,0
S FG	Order-No	ø 1/10 mm
D	314 826 ...	018
P		1



829L

ISO 236

= 6

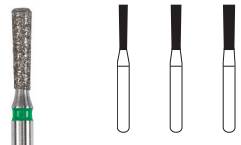

L		6,0	6,0	6,0
S FG	Order-No	ø 1/10 mm		
D	314 829L...			016
	314 G 829L...	012	014	016
P		1	1	1



830

ISO 238

= 6

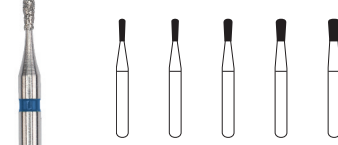

L		3,0	3,0	3,0	3,0	3,0
S FG	Order-No	ø 1/10 mm				
D	314 C 830 ...	010	012	014	016	
	314 F 830 ...	010	012	014	016	
	314 830 ...	009	010	012	014	016
	314 G 830 ...	010	012	014	016	
	314 SG 830 ...		012	014	016	
P		1	1	1	1	1
S FG_{short}	Order-No	ø 1/10 mm				
D	313 830 ...	010	012			
P		1	1			



830L

ISO 239

= 6

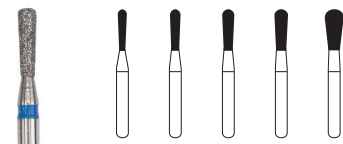

L		5,5	5,5	5,5	5,5	5,5
S FG	Order-No	ø 1/10 mm				
D	314 C 830L...	012	014		018	
	314 F 830L...	012	014	016		
	314 830L...	012	014	016	018	025
	314 G 830L...	012	014	016	018	
	314 SG 830L...	012	014	016		
P		1	1	1	1	2
S FG_{short}	Order-No	ø 1/10 mm				
D	313 830L...	014				
P		1				



833

ISO 463

= 6

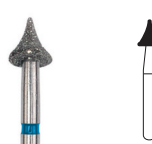

L		3,5
S FG	Order-No	ø 1/10 mm
D	314 F 833 ...	031
	314 833 ...	031
P		4



835
ISO 107

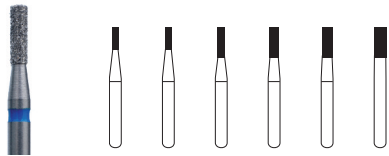

		L	3,5	3,5	4,0	4,0	4,0	4,5
S FG	Order-No	ø 1/10 mm						
D	314 C 835 ...	008						
	314 F 835 ...			010	012	014		
	314 835 ...	008	009	010	012	014	016	
	314 G 835 ...	008	009	010	012	014	016	
	314 SG 835 ...			010	012	014	016	
P		1	1	1	1	1	1	
S FGshort	Order-No	ø 1/10 mm						
D	313 835 ...	008	009	010				
P		1	1	1				
		L	5,0	5,0				
S RA	Order-No	ø 1/10 mm						
D	204 835 ...			010	012			
P				11	11			



835KR
ISO 156

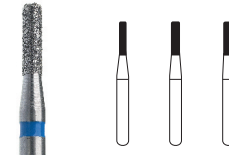

		L	4,5	4,5	4,5
S FG	Order-No	ø 1/10 mm			
D	314 F 835KR ...	010	012		
	314 835KR ...	010	012	014	
	314 G 835KR ...	010	012		
P		1	1	1	



836
ISO 110

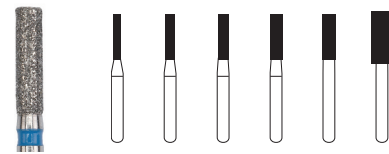

		L	6,5	6,5	6,5	6,5	6,5	7,5
S FG	Order-No	ø 1/10 mm						
D	314 F 836 ...	010	012	014			018	
	314 836 ...	010	012	014			018	027
	314 G 836 ...	010	012	014	016	018		
	314 SG 836 ...	010	012	014			027	
P		1	1	1	1	1	2	
S FGshort	Order-No	ø 1/10 mm						
D	313 836 ...		012	014				
P			1	1				



836KR
ISO 157



		L	5,0	5,0
S FG	Order-No	ø 1/10 mm		
D	314 F 836KR...	012		
	314 836KR...	012	014	
	314 G 836KR...		014	
P		1	1	



837
ISO 111

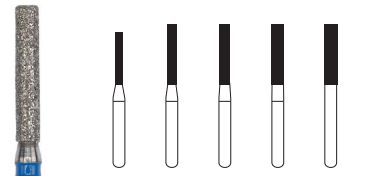

		L	7,5	8,0	8,0	8,0	8,0
S FG	Order-No	ø 1/10 mm					
D	314 F 837 ...	010	012	014	016	018	
	314 837 ...	010	012	014	016	018	
	314 G 837 ...	010	012	014	016	018	
	314 SG 837 ...	010	012	014	016		
P		1	1	1	1	1	
S FGshort	Order-No	ø 1/10 mm					
D	313 837 ...			014			
P				1			



837L
ISO 112



		L	10,0	10,0	10,0	10,0
S FG	Order-No	ø 1/10 mm				
D	314 F 837L...	012	014			
	314 837L...	012	014	016	018	
	314 G 837L...	012	014	016		
P		1	1	1	1	



837KR

ISO 158

$\square = 6$

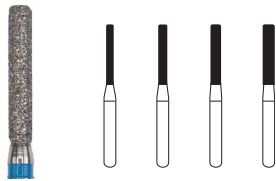

L		8,0	8,0	8,0	8,0
S FG	Order-No	ø 1/10 mm			
D	314 F 837KR...		014	016	
	314 837KR...	010	012	014	016
	314 G 837KR...	010	012	014	016
P		1	1	1	1



838

ISO 137

$\square = 6$

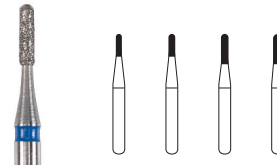

L		3,5	3,5	4,0	4,0
S FG	Order-No	ø 1/10 mm			
D	314 F 838 ...			010	012
	314 838 ...	008	009	010	012
	314 G 838 ...			010	012
	314 SG 838 ...			010	012
P		1	1	1	1



839

ISO 150

$\square = 6$

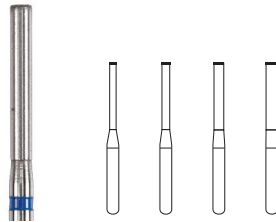

L		-	-	-	-
S FG	Order-No	ø 1/10 mm			
D	314 839 ...	010	012	014	016
P		2	2	2	2



845

ISO 170

$\square = 6$

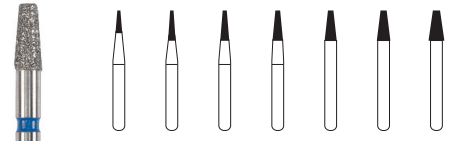

L		3,5	4,0	4,0	4,0	4,0	4,0	4,0
S FG	Order-No	ø 1/10 mm						
D	314 F 845 ...		010	012	014	016		
	314 845 ...	009	010	012	014	016	018	021
	314 G 845 ...		010	012	014	016		
	314 SG 845 ...			012	014			
P		1	1	1	1	1	1	2



845KR

ISO 544

$\square = 6$



L		4,0
S FG	Order-No	ø 1/10 mm
D	314 F 845KR...	025
	314 G 845KR...	025
P		2



846

ISO 171

$\square = 6$

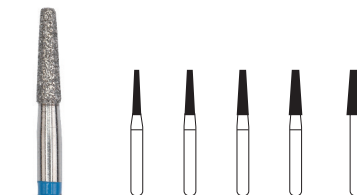

L		6,0	6,0	6,0	6,0	7,0
S FG	Order-No	ø 1/10 mm				
D	314 F 846 ...	012		016		025
	314 846 ...	012	014	016		025
	314 G 846 ...	012		016	018	025
	314 SG 846 ...	012		016		
P		1	1	1	1	2



846KR

ISO 545

$\square = 6$



L		6,0	7,0
S FG	Order-No	ø 1/10 mm	
D	314 F 846KR...	018	025
	314 846KR...	018	
P		1	2



847

ISO 172

$\square = 6$

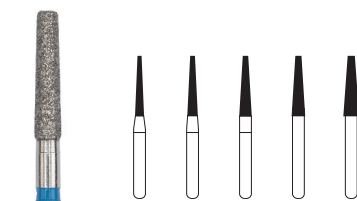

L		8,0	8,0	8,0	8,0	8,0
S FG	Order-No	ø 1/10 mm				
D	314 F 847 ...	012	014	016	018	021
	314 847 ...	012	014	016	018	021
	314 G 847 ...	012	014	016	018	
	314 SG 847 ...	012	014	016	018	021
P		1	1	1	1	2
S FG_{short}	Order-No	ø 1/10 mm				
D	313 847 ...	012	014			
P		1	1			



847KR

ISO 546

= 6



L		8,0	
S FG	Order-No	ø 1/10 mm	
D	314 F 847KR...	016	
	314 847KR...	016	
	314 G 847KR...	016	
P		1	



848

ISO 173

= 6

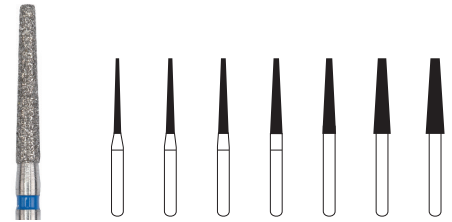

L		10,0 10,0 10,0 10,0 10,0 10,0 10,0						
S FG	Order-No	ø 1/10 mm						
D	314 C 848 ...	012	016					
	314 F 848 ...	012	014	016	018	025		
	314 848 ...	010	012	014	016	018	023 025	
	314 G 848 ...	010	012	014	016	018	023 025	
	314 SG 848 ...	012	014	016	018			
P		1	1	1	1	1	2 2	
S FGshort	Order-No	ø 1/10 mm						
D	313 848 ...	016						
P		1						



848L

ISO 174

= 6



L		11,5	
S FG	Order-No	ø 1/10 mm	
D	314 848L...	014	
P		1	



849

ISO 196

= 6

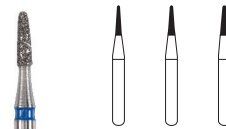

L		4,0 4,0 4,0		
S FG	Order-No	ø 1/10 mm		
D	314 C 849 ...	009		
	314 F 849 ...	009	012	
	314 849 ...	009	010	012
	314 G 849 ...		010	012
	314 SG 849 ...			012
P		1	1	1



850

ISO 199

= 6

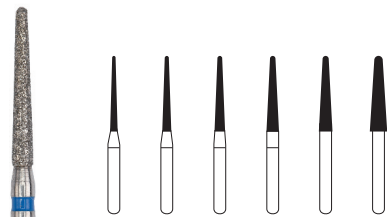

L		10,0 10,0 10,0 10,0 10,0 10,0					
S FG	Order-No	ø 1/10 mm					
D	314 C 850 ...	012	014	016			
	314 F 850 ...	010	012	014	016	018 023	
	314 850 ...	010	012	014	016	018 023	
	314 G 850 ...	010	012	014	016	018 023	
	314 SG 850 ...		012	014	016	018 023	
P		1	1	1	1	2	
L		10,0 10,0					
S RA	Order-No	ø 1/10 mm					
D	204 850 ...	012	014				
P		11	11				



850L

ISO 200

= 6



L		11,5 11,5 11,5		
S FG	Order-No	ø 1/10 mm		
D	314 850L...	016	018	
	314 G 850L...	014	016	018
	314 SG 850L...	014	016	018
P		1	1	1



851

ISO 219



L		8,0	8,0	8,5
S FG	Order-No	ø 1/10 mm		
D	314 F 851 ...	012		016
	314 851 ...	012	014	016
	314 G 851 ...	012	014	
P		1	1	1



852

ISO 164

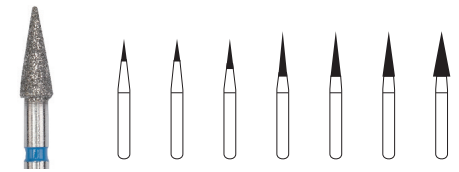

L		3,0	3,5	4,5	6,0	6,0	6,0	6,0
S FG	Order-No	ø 1/10 mm						
D	314 C 852 ...				010	012	014	
	314 F 852 ...				008	010	012	016
	314 852 ...			008	009	010	012	016 023
	314 G 852 ...					010	012	023
	314 SG 852 ...						012	
P		1	1	1	1	1	1	2
S FGshort	Order-No	ø 1/10 mm						
D	313 852 ...					012		
P		1						



855

ISO 197



L		6,5	7,0	7,0
S FG	Order-No	ø 1/10 mm		
D	314 F 855 ...	012	014	
	314 855 ...	012	014	016
	314 G 855 ...	012	014	
P		1	1	1



856

ISO 198

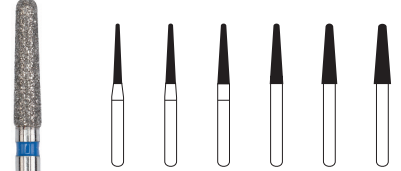

L		8,0	8,0	8,0	8,0	8,0	8,0	
S FG	Order-No	ø 1/10 mm						
D	314 C 856 ...	012			016		023	
	314 F 856 ...	012	014	016	018	021	023	
	314 856 ...	012	014	016	018	021	023	
	314 G 856 ...	012	014	016	018	021	023	
	314 SG 856 ...	012	014	016	018	021	023	
P		1	1	1	1	2	2	
S FGshort	Order-No	ø 1/10 mm						
D	313 856 ...			014	016			
	313 SG 856 ...			014	016			
P		1 1						



856L

ISO 198



L		9,0	9,0	9,0	9,0
S FG	Order-No	ø 1/10 mm			
D	314 856L...	012	014	018	023
	314 G 856L...	012	014	018	
P		1	1	1	2



857

ISO 220



L		10,0	10,0
S FG	Order-No	ø 1/10 mm	
D	314 F 857 ...	014	
	314 857 ...	014	016
P		1	1



858

ISO 165

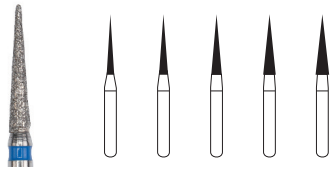

L		8,0	8,0	8,0	8,0	8,0
S FG	Order-No	ø 1/10 mm				
D	314 C 858 ...	012	014	016		
	314 F 858 ...	012	014	016		
	314 858 ...	010	012	014	016	018
	314 G 858 ...	012	014	016	018	
	314 SG 858 ...		014			
P		1	1	1	1	1
S FGshort	Order-No	ø 1/10 mm				
D	313 858 ...		014			
P		1				



859

ISO 166

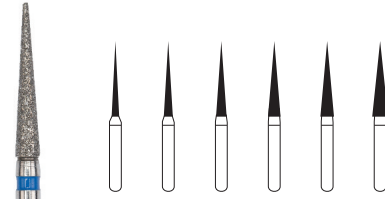

L		10,0	10,0	10,0	10,0	10,0	10,0
S FG	Order-No	ø 1/10 mm					
D	314 C 859 ...	010	012	014	016		
	314 F 859 ...	010	012	014	016	018	
	314 859 ...	010	012	014	016	018	
	314 G 859 ...	010	012	014	016	018	021
	314 SG 859 ...	010	012	014	016	018	
P		1	1	1	1	1	2
S FGshort	Order-No	ø 1/10 mm					
D	313 859 ...	010			016		
P		1			1		
L		10,0	10,0				
S RA	Order-No	ø 1/10 mm					
D	204 859 ...		012		016		
P		11			11		



859L

ISO 167

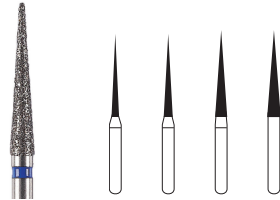

L		11	11	11,5	11,5
S FG	Order-No	ø 1/10 mm			
D	314 F 859L ...	010	012		
	314 859L ...	010	012	016	018
	314 G 859L ...				018
P		1	1	1	1



860

ISO 247

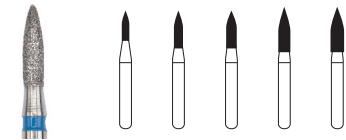

L		5,0	5,0	5,0	6,0	6,0
S FG	Order-No	ø 1/10 mm				
D	314 C 860 ...	010	012	014		
	314 F 860 ...	010	012	014		
	314 860 ...	010	012	014	016	018
	314 G 860 ...	010	012	014		
P		1	1	1	1	1
L		5,0				
S RA	Order-No	ø 1/10 mm				
D	204 860 ...				016	
P		11				



861

ISO 248



L		6,0
S FG	Order-No	ø 1/10 mm
D	314 G 861 ...	014
P		1



862

ISO 249

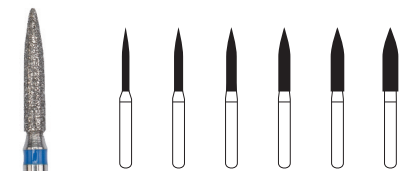

L		8,5	8,5	8,5	8,5	8,5	8,5
S FG	Order-No	ø 1/10 mm					
D	314 C 862 ...	010	012	014	016		
	314 F 862 ...	010	012	014	016		
	314 862 ...	010	012	014	016	018	021
	314 G 862 ...	010	012	014	016	018	
	314 SG 862 ...	010	012	014	016		
P		1	1	1	1	1	2
S FGshort	Order-No	ø 1/10 mm					
D	313 862 ...		012				
P		1					



863

ISO 250

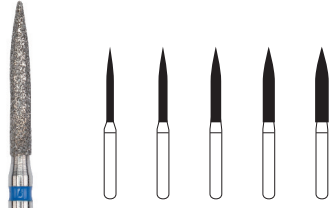

L		10,0 10,0 10,0 10,0 10,0				
S FG	Order-No	ø 1/10 mm				
D	314 C 863 ...	012	016			
	314 F 863 ...	012	014	016	018	
	314 863 ...	010	012	014	016	018
	314 G 863 ...	012	014	016	018	
	314 SG 863 ...	012	016			
P		1	1	1	1	1



864

ISO 251



L		12,0	
S FG	Order-No	ø 1/10 mm	
D	314 C 864 ...	014	
	314 864 ...	014	
P		1	



868K

ISO 223



L		8,0 8,0	
S FG	Order-No	ø 1/10 mm	
D	314 F 868K...	012	016
	314 868K...	012	016
P		1	1



869K

ISO 222



L		6,0	
S FG	Order-No	ø 1/10 mm	
D	314 869K...	014	
P		1	



874

ISO 534



L		2,0	
S FG	Order-No	ø 1/10 mm	
D	314 874 ...	009	
P		1	



875

ISO 535



L		3,0	
S FG	Order-No	ø 1/10 mm	
D	314 F 875 ...	009	
	314 875 ...	009	
P		1	



876

ISO 287



L		5,0	
S FG	Order-No	ø 1/10 mm	
D	314 C 876 ...	010	
	314 F 876 ...	010	
	314 876 ...	010	
	314 G 876 ...	010	
P		1	



877

ISO 288



L		6,5 6,5	
S FG	Order-No	ø 1/10 mm	
D	314 C 877 ...	010	
	314 F 877 ...	010	012
	314 877 ...	010	012
	314 G 877 ...	010	012
	314 SG 877 ...	010	012
P		1	1



877K

ISO 297

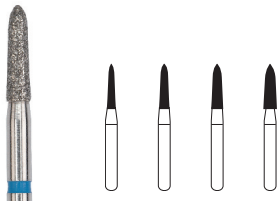

L		6,0 6,0 6,0 6,0			
S FG	Order-No	ø 1/10 mm			
D	314 C 877K...	014			
	314 F 877K...	012	014		
	314 877K...	012	014	016	018
	314 G 877K...	012	014		
	314 SG 877K...	012	014	016	
P		1	1	1	1



878

ISO 289



L		8,0 8,0 8,0 8,0 8,0					
S FG	Order-No	ø 1/10 mm					
D	314 C 878 ...	010	012	014			
	314 F 878 ...	010	012	014	016	018	
	314 878 ...	010	012	014	016	018	
	314 G 878 ...	010	012	014	016	018	
	314 SG 878 ...	010	012	014	016		
P		1	1	1	1	1	
S FGshort	Order-No	ø 1/10 mm					
D	313 878 ...	012	014				
P		1	1				



878K

ISO 298

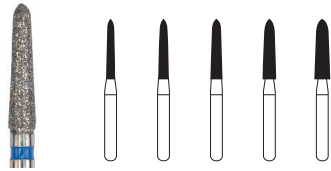

S FG		L	8,0 8,0 8,0 8,0 8,0				
Order-No		ø 1/10 mm					
D	314 C	878K...				018	
	314 F	878K...	014	016	018	021	
	314	878K...	012	014	016	018 021	
	314 G	878K...	012	014	016	018 021	
	314 SG	878K...	014	016	018	021	
P			1	1	1	2	



879

ISO 290

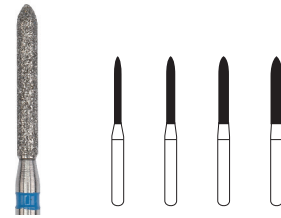

S FG		L	10,0 10,0 10,0 10,0			
Order-No		ø 1/10 mm				
D	314 C	879 ...	012	014		
	314 F	879 ...	012	014	016	
	314	879 ...	012	014	016	
	314 G	879 ...	010	012	014	016
	314 SG	879 ...	012	014	016	
P			1	1	1	1



879K

ISO 299

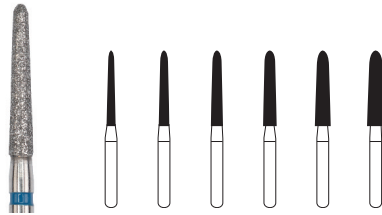

S FG		L	10,0 10,0 10,0 10,0 10,0 10,0					
Order-No		ø 1/10 mm						
D	314 C	879K...	014	016	018			
	314 F	879K...	014	016	018			
	314	879K...	012	014	016	018	021 023	
	314 G	879K...	012	014	016	018	021 023	
	314 SG	879K...	014	016	018	021		
P			1	1	1	2	2	



880

ISO 140

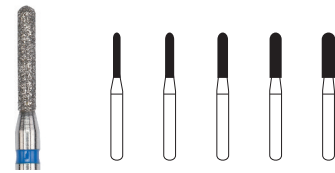

S FG		L	6,5 6,5 6,5 6,5 6,5				
Order-No		ø 1/10 mm					
D	314 C	880 ...		014			
	314 F	880 ...		012	014		
	314	880 ...	010	012	014	016 018	
	314 G	880 ...	010	012	014		
	314 SG	880 ...		014			
P			1	1	1	1	



880SH

ISO 139



S FG		L	4,5 4,5	
Order-No		ø 1/10 mm		
D	314	880SH ...	010	014
	314 G	880SH ...	010	
P			1	1



881

ISO 141



S FG		L	8,5 8,5 8,5 8,5 8,5				
Order-No		ø 1/10 mm					
D	314 C	881 ...	012	014	016	018	
	314 F	881 ...	010	012	014	016 018	
	314	881 ...	010	012	014	016 018	
	314 G	881 ...	010	012	014	016 018	
	314 SG	881 ...	012	014	016	018	
P			1	1	1	1	



882

ISO 142



S FG		L	10,5 10,5 10,5 10,5			
Order-No		ø 1/10 mm				
D	314	882 ...	012	014	018	
	314 G	882 ...	012	014	016	018
P			1	1	1	1



883

ISO 536



S FG		L	3,0
Order-No		ø 1/10 mm	
D	314 F	883 ...	010
	314	883 ...	010
P			1



884

ISO 129



L		6,0	
S FG	Order-No	ø 1/10 mm	
D	314 C 884 ...	012	
	314 884 ...	012	
	314 G 884 ...	012	
P		1	



885

ISO 130

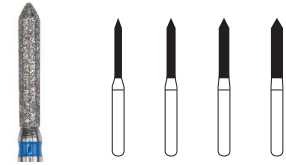

L		8,0			
S FG	Order-No	ø 1/10 mm			
D	314 C 885 ...	012	014		
	314 F 885 ...	012	014		
	314 885 ...	010	012	014	016
	314 G 885 ...	012	014	016	
	314 SG 885 ...	012			
P		1	1	1	1



886

ISO 131



L		10,0			
S FG	Order-No	ø 1/10 mm			
D	314 F 886 ...	010	012	014	016
	314 886 ...		012	014	016
	314 G 886 ...		012	014	016
	314 SG 886 ...		012	014	
P		1	1	1	1



888

ISO 496



L		8,0	
S FG	Order-No	ø 1/10 mm	
D	314 C 888 ...	012	
	314 888 ...	012	
	314 G 888 ...	012	
P		1	

PX

889

ISO 540



L		5,0	
S FG	Order-No	ø 1/10 mm	
D	314 C 889 ...	009	010
	314 F 889 ...	009	010
	314 889 ...	009	010
	314 G 889 ...	009	010
P		1 1	



899

ISO 033



L		7,0		
S FG	Order-No	ø 1/10 mm		
D	314 F 899 ...	021	027	
	314 899 ...	021	027	031
	314 G 899 ...	021		
P		2	2	4



909

ISO 068

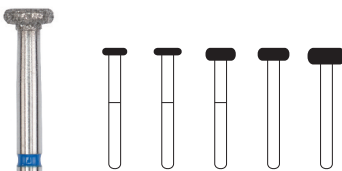

L		1,0 2,0 2,0 2,0 2,5				
S FG	Order-No	ø 1/10 mm				
D	314 909 ...	033	037	040	042	050
	314 G 909 ...		037	040	042	
	314 SG 909 ...			040		
P		4	4	4	4	4
S FGshort	Order-No	ø 1/10 mm				
D	313 909 ...				042	
P		4				

PX

955

ISO 699

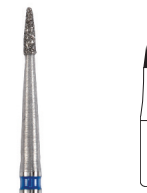

L		3,5	
S FG	Order-No	ø 1/10 mm	
D	314 955 ...	008	
P		1	



956

ISO 159

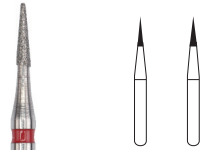

L		4,0	4,0
S FG	Order-No	ø 1/10 mm	
D	314 F 956 ...	008	010
P		1	1



369

ISO 263



L		5,5
S FG	Order-No	ø 1/10 mm
D	314 369 ...	025
P		2



370

ISO 507



L		5,5
S FG	Order-No	ø 1/10 mm
D	314 F 370 ...	023
	314 370 ...	023
	314 G 370 ...	023
P		2



390

ISO 274



L		3,0
S FG	Order-No	ø 1/10 mm
D	314 C 390 ...	016
	314 F 390 ...	016
	314 390 ...	016
	314 G 390 ...	016
P		1



368

ISO 257

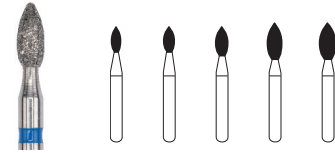

L		3,5	3,5	4,0	4,5	5,0
S FG	Order-No	ø 1/10 mm				
D	314 C 368 ...	014	016	018	021	023
	314 F 368 ...		016	018	021	023
	314 368 ...	014	016	018	021	023
	314 G 368 ...		016	018	021	023
	314 SG 368 ...		016	018	021	023
P		1	1	1	2	2
S FGshort	Order-No	ø 1/10 mm				
D	313 368 ...	016				
P		1				
L		5,5 5,5				
S RA	Order-No	ø 1/10 mm				
D	204 368 ...	021 023				
P		12 12				



379

ISO 277



L		3,0	3,0	3,5	3,5	4,5
S FG	Order-No	ø 1/10 mm				
D	314 C 379 ...	014		018	023	
	314 F 379 ...	014	016	018	023	
	314 379 ...	012	014	018	023	
	314 G 379 ...	014	016	018	023	
	314 SG 379 ...			018	023	
P		1	1	1	1	2
S FGshort	Order-No	ø 1/10 mm				
D	313 SG 379 ...	023				
P		2				



392

ISO 465



L		5,0
S FG	Order-No	ø 1/10 mm
D	314 F 392 ...	016
	314 392 ...	016
P		1

FG turbo grinders

FG Turbo

FG Turboschleifer

Fresas diamantadas FG con espiral

Frese diamantate FG a spirale



R 837

ISO 115

= 6



L		8,0	10,0
S	FG	Order-No	ø 1/10 mm
D		314 R 837 ...	014 018
		314 SG R 837 ...	014 018
P		4	4



R 847

ISO 177

= 6



L		8,0	
S	FG	Order-No	ø 1/10 mm
D		314 R 847 ...	016
		314 SG R 847 ...	016
P		4	



R 848

ISO 178

= 6



L		10,0	10,0
S	FG	Order-No	ø 1/10 mm
D		314 R 848 ...	018 025
		314 SG R 848 ...	018 025
P		4	4



FG diamonds reducers and depth markers

Diamants FG réducteurs et marqueurs de profondeur

FG Diamanten Reduzierer und Tiefenmarkierer

Fresas diamantadas FG reductores y marcadores de profundidad

Riduttori e incisori di profondità FG



RD 655

ISO 519

= 6



L	9,0
S FG	Order-No
D	314 G RD 655 ... 018
P	4



RD 834

ISO 552

= 6

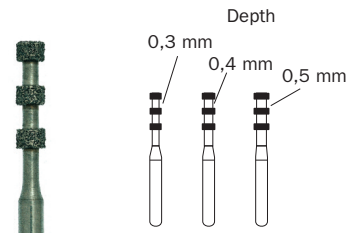

L	7,0	7,0	7,0
S FG	Order-No	ø 1/10 mm	
D	314 RD 834 ... 016	018	021
	314 G RD 834 ...	018	
P	4	4	4



RD 837

ISO 515

= 6



L	8,0
S FG	Order-No
D	314 RD 837 ... 016
	314 G RD 837 ... 016
P	4



RD 848

ISO 520

= 6



L	10,0
S FG	Order-No
D	314 RD 848 ... 016
	314 G RD 848 ... 016
P	4



FG diamonds microprep

Diamants FG microprep

FG Diamanten Microprep

Fresas diamantadas FG microprep

Frese diamantate FG microprep



MP 801

ISO M 001

= 6

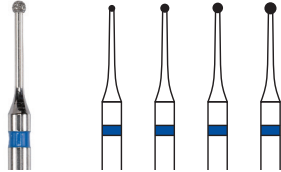

L		-			
S FG	Order-No	ø 1/10 mm			
D	314 F MP 801 ...	009			
	314 MP 801 ...	009	012	014	016
P		2	2	2	2



MP 830

ISO M 237

= 6



L		2,6	2,6
S FG	Order-No	ø 1/10 mm	
D	314 F MP 830 ...	009	012
	314 MP 830 ...	009	012
P		2	2



MP 835KR

ISO M 156

= 6

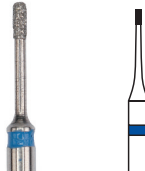

L		2,0
S FG	Order-No	ø 1/10 mm
D	314 MP 835KR ...	008
P		2



MP 889

ISO M 537

= 6

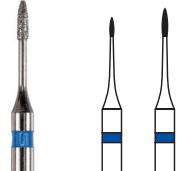

L		2,7	3,9
S FG	Order-No	ø 1/10 mm	
D	314 F MP 889 ...	007	009
	314 MP 889 ...	007	009
P		2	2



MP 368

ISO M 244

= 6



L		2,6
S FG	Order-No	ø 1/10 mm
D	314 F MP 368 ...	012
	314 MP 368 ...	012
P		2



MP 802

ISO M 019

= 6

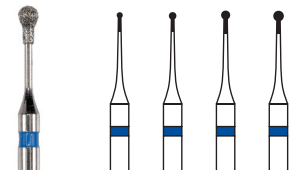

L		2,5	2,5	3,0	3,0
S FG	Order-No	ø 1/10 mm			
D	314 F MP 802 ...	008	010	012	014
	314 MP 802 ...	008	010	012	014
P		2	2	2	2



MP 830RM

ISO M 237

= 6

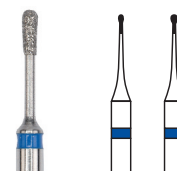

L		2,5	2,5
S FG	Order-No	ø 1/10 mm	
D	314 F MP 830RM ...	008	010
	314 MP 830RM ...	008	010
P		2	2



MP 838

ISO M 138

= 6



L		2,6
S FG	Order-No	ø 1/10 mm
D	314 F MP 838 ...	007
	314 MP 838 ...	007
P		2



MP 890

ISO M 271

= 6



L		3,0
S FG	Order-No	ø 1/10 mm
D	314 F MP 890 ...	014
	314 MP 890 ...	014
P		2



Perio diamond instruments

Instruments diamantés perio

Perio Instrumente



Instrumentos diamantados perio



Frese diamantate perio

 

831
ISO 267

 = 6









L		7,0	
S	RA	Order-No	ø 1/10 mm
D		205 C 831 ...	012
		205 F 831 ...	012
		205 831 ...	012
P		4	



 

831L
ISO 268

 = 6









L		7,0	
S	RA	Order-No	ø 1/10 mm
D		205 C 831L...	012
		205 F 831L...	012
		205 831L...	012
P		4	



 

832
ISO 258

 = 6









L		5,0	
S	RA	Order-No	ø 1/10 mm
D		205 C 832 ...	014
		205 F 832 ...	014
		205 832 ...	014
P		4	

832L
ISO 259

 = 6

L		5,0	
S	RA	Order-No	ø 1/10 mm
D		205 C 832L...	014
		205 F 832L...	014
		205 832L...	014
P		4	



P 856

Crown prep tool

ISO 508

= 6



L	8
S FG	Order-No
D	314 SG P 856 ...
P	3

FG preparation tools with guide pin

Outils de préparation avec guide FG

FG Präparationswerkzeuge mit Führungspin

Fresas diamantadas FG con pin de guia

Frese diamantate FG con punta di riferimento



P 850

Crown prep tool

anterior

ISO 198

= 6



L	8
S FG	Order-No
D	314 SG P 850 ...
P	3



P 856

Crown prep tool

anterior

ISO 508

= 6



L	9
S FG	Order-No
D	314 F P 856 ...
P	3



P 850

Crown prep tool

posterior

ISO 198

= 6



L	8
S FG	Order-No
D	314 SG P 850 ...
P	4



P 856

Crown prep tool

posterior

ISO 508

= 6



L	9
S FG	Order-No
D	314 F P 856 ...
P	4



P 850

Crown prep tool

allceramics

ISO 152

= 6



L	8
S FG	Order-No
D	314 SG P 850 ...
P	4



P 856

Crown prep tool

allceramics

ISO 509

= 6



L	8
S FG	Order-No
D	314 F P 856 ...
P	4



P 850Z

Crown prep tool

zirconia

ISO 152

= 6



L	8
S FG	Order-No
D	314 SG P 850Z ...
P	3



P 856

Crown prep tool

zirconia

ISO 509

= 6



L	8
S FG	Order-No
D	314 F P 856 ...
P	3

- Preparation tools for metal, allceramics and zirconia
- Ideal preparation of the margin line
- Helps respect recommended wall strengths
- Non-diamond coated pin to avoid injury

- Instruments pour la préparation, idéal pour métal, tout-céramique et zircon
- Idéal pour la définitions de la ligne de préparation
- Facilite le respect de l'épaisseur des parois
- Pointe-guide non-diamantée, évite d'éventuelles lésions

- Präparationsinstrumente für Metall, Vollkeramik und Zirkon
- Ideal zur Festlegung der Präparationsgrenze
- Erleichtert die Einhaltung der empfohlenen Wandstärke
- Nicht-diamantierter Führungspin zur Vermeidung von Verletzungen.

- Instrumentos de preparación para metal, cerámica sin metal y circonio
- Ideal para establecer el limite de preparación
- Facilita la observancia del espesor de pared recomendado
- Pin de guia no diamantado para evitar lesiones

- Strumenti per la preparazione di corone in metallo, zirconio e ceramica integrale
- Ideale per la delimitazione della preparazione marginale
- Facilita il mantenimento dei parametri dello spessore delle pareti
- Punta di delimitazione non diamantata per evitare ferite

FG diamonds for zirconia / allceramics

Diamants FG pour zircon / céramique sans métal

FG Diamanten für Zirkon / Vollkeramik

Fresas diamantadas FG para zirconio / cerámica sin metal

Frese diamantata FG per zirconio / ceramica integrale

830L
ISO 239
= 6



L	6,0	
S FG	Order-No	ø 1/10 mm
D	314 ZF 830L ...	018
	314 Z 830L ...	018
P	3	

877K
ISO 297
= 6



L	6,0	
S FG	Order-No	ø 1/10 mm
D	314 ZF 877K ...	016
	314 Z 877K ...	016
P	3	

- Specially designed diamond coating
- Superior abrasive effect
- Excellent operating life
- **Water cooling required**

- Revêtement en diamant spécial
- Importante capacité abrasive
- Excellente durée de vie
- **Refroidissement à eau**

- Spezielle Diamantbeschichtung
- Ausgezeichnete Abtragsleistung
- Hohe Standzeit
- **Wasserkühlung**

368
ISO 257
= 6



L	4,5	
S FG	Order-No	ø 1/10 mm
D	314 ZF 368 ...	021
	314 Z 368 ...	021
P	4	

379
ISO 277
= 6



L	3,5	
S FG	Order-No	ø 1/10 mm
D	314 ZF 379 ...	016
	314 Z 379 ...	016
P	3	

- Diamantado especial para zirconio
- Importante fuerza de abrasión
- Excelente vida útil
- **Refrigeración por agua**

- Diamantatura speciale
- Sgrossatura veloce e efficiente
- Di lunga durata
- **Raffreddamento ad acqua**

Zirconia Adjustment Set

P: 362
S: FG/RA

F	830L	368	856	379	243	243	243	372
L	6,0	4,5	8,0	5,5	10,5	10,5	10,5	3,0
S	FG	FG	FG	FG	RA	RA	RA	RA
ø	018	021	018	023	045	045	045	090
Step	-	-	-	-	1	2	3	-
D	■	■	■	■	-	-	-	-
P	3	3	3	4	70	70	70	76
Order-No	314 Z 830L 018	314 Z 368 021	314 FSG 856 018	314 FSG 379 023	150 RA	160 RA	170 RA	260 RA



Crown cutters

Coupe couronnes

Kronentrenner

Disco para cortar coronas

Tagliacorone

Diazircon crown cutter

- Diamond-coated disk for separating crowns and bridges made of zirconia and full ceramics.
- Heat-related damage to the dental pulp can be avoided if used correctly, as the disk and diamond coating are designed to provide a maximum cooling effect.
- Avoid tilting, do not use the disk as a lever.
- Avoid contact with soft tissue, risk of injury!
- Water cooling required.

Recommended speed:
15' – 25000 rpm.
Pu: single



943

Diazircon
ISO 369



L	0,6
S RA	Order-No
	204 943 ...
P	7



943

Diazircon
ISO 369



L	0,6
S HP	Order-No
	104 943 ...
P	7

Diazircon coupe couronne

- Disque diamanté pour la séparation de couronnes et de bridges en zircon et céramo-céramique.
- Correctement utilisé, le disque diamanté permet un effet de refroidissement optimal afin d'éviter toute lésion de la pulpe.
- Éviter d'incliner le disque. Ne pas utiliser le disque comme levier.
- Éviter absolument tout contact avec les tissus mous. Risque de blessure !
- Refroidissement par eau nécessaire.

Vitesse de rotation :
15 - 25'000 tpm.
Conditionnement : 1 pièce

Diazircon crown cutter

- Diamantbeschichtete Scheibe zum Trennen von Kronen und Brücken aus Zirkon und Vollkeramik.
- Bei korrekter Anwendung können Pulpaschädigungen durch Hitzeentwicklung während des Trennvorgangs vermieden werden, da die Scheibengestaltung und die Diamantbeschichtung auf maximalen Kühlungseffekt ausgelegt sind.
- Verkanten unbedingt vermeiden, Scheibe nicht als Hebel einsetzen.
- Kontakt mit Weichgewebe vermeiden, Verletzungsgefahr!
- Wasserkühlung erforderlich.

Drehzahl: 15' – 25000 UpM.
VE: 1 Stück

Diazircon crown cutter

- Disco diamantado para separar coronas y puentes de zirconio y de cerámica sin metal.
- El diseño y el revestimiento diamantado del disco han sido concebidos para ofrecer un efecto de refrigeración máximo, por eso, si el instrumento se usa correctamente la pulpa no resulta dañada por el sobrecalentamiento generado durante el proceso de la separación.
- Evitar siempre los ladeos, no usar el disco como palanca.
- ¡Evitar el contacto con el tejido blando, peligro de lesiones!
- Se requiere refrigeración por agua.

Velocidad: 15.000 – 25.000 rpm.
Envase: 1 unidad

Diazircon crown cutter

- Disco diamantato per il taglio di corone e ponti in zirconia e ceramica integrale.
- In caso di utilizzo corretto, durante il processo di taglio è possibile evitare lesioni pulpari dovute alla formazione di calore, poiché il design del disco e il rivestimento diamantato sono progettati per ottenere il massimo effetto di raffreddamento.
- Evitare assolutamente angolazioni e non utilizzare il disco come leva.
- Evitare assolutamente il contatto con il tessuto molle. Pericolo di lesioni!
- È necessario un raffreddamento ad acqua.

Velocità: 15' – 25000 giri/min.
Confezione: 1 unità

Zirconia crown cutter

- For cutting zirconia and all-ceramic crowns
- Avoid any contact with soft tissue, risk of injury!
- Water cooling needed

Speed: 30' - 300.000 rpm.



881Z
ISO 141



L		8,5
S FG	Order-No	∅ 1/10 mm
D	314 G 881Z ...	016
P		5



Coupe couronnes pour zircon

- Pour la découpe de couronnes en zircon et tout-céramique
- Éviter tout contact avec des tissus mous, risque de lésion!
- Irrigation nécessaire

Vitesse : 30' - 300'000 tpm.

Kronentrenner für Zirkon

- Zum Trennen von Kronen aus Zirkon und Vollkeramik
- Kontakt mit Weichgewebe unbedingt vermeiden, Verletzungsgefahr!
- Wasserkühlung erforderlich

Drehzahl: 30' - 300.000 UpM.

Cortadores de coronas para zirconia

- Para la separación de coronas de circonio y cerámica sin metal
- Evitar el contacto con el tejido blando, peligro de lesiones
- Refrigeración por agua necesaria

Velocidad: 30' - 300.000 rpm.

Tagliacorone per lo zirconio

- Per la separazione di corone in zirconio e ceramica integrale
- Evitare assolutamente il contatto con il tessuto molle
- Raffreddamento ad acqua necessario

Velocità: 30' - 300.000 giri/min.

Trepanation instrument for zirconia

Speed: 30' - 300.000 rpm.



389T
ISO 005



L		6,5
S FG	Order-No	∅ 1/10 mm
D	314 G 389T ...	021
P		5



Instrument pour trépaner le zircon

Vitesse : 30' - 300'000 tpm.

Trepanierinstrument für Zirkon

Drehzahl: 30' - 300.000 UpM.

Instrumento para trepanación de circonio

Velocidad: 30' - 300.000 rpm.

Strumento per trepanare lo zirconio

Velocità: 30' - 300.000 giri/min.

Diasoft crown cutter

- Sintered-diamond disk for the injury-free cutting of crowns and bridges.
- Damage to soft tissue caused by the rotating disk will not occur when used correctly due to the sintered-diamond structure.
- Avoid tilting, do not use the disk as a lever.
- Water cooling required.



943S

Diasoft crown cutter
ISO 345



	L	0,3	0,3
S RA	Order-No	ø 1/10 mm	
	204 943S ...	090	100
	P	8	8

Recommended speed:

15' - 20000 rpm.

Pu: single

Diasoft coupe couronne

- Disque en diamant fritté pour séparation de couronnes et de bridges sans risque de blessure du tissu mou.
- Lorsque l'instrument est correctement utilisé, la structure frittée du diamant évite les blessures en cas de contact du disque en rotation avec le tissu mou.
- Éviter absolument d'incliner le disque. Ne pas utiliser le disque comme levier.
- Refroidissement par eau nécessaire.

Vitesse : 15 - 20'000 tpm.

Conditionnement : 1 pièce

Diasoft Kronentrenner

- Sinterdiamantscheibe zum verletzungs-freien Auftrennen von Kronen und Brücken.
- Bei korrekter Anwendung treten aufgrund der Sinterdiamantstruktur im Fall von Berührungen der rotierenden Scheibe am Weichgewebe keine Verletzungen auf.
- Verkanten unbedingt vermeiden, Scheibe nicht als Hebel einsetzen.
- Wasserkühlung erforderlich.

Drehzahl: 15' - 20000 UpM.

VE: 1 Stück

Diasoft disco para cortar coronas

- Discos de diamante sinterizado para separar coronas y puentes sin lesiones.
- Si el disco se emplea correctamente, la estructura del diamante sinterizado impide que se produzcan lesiones cuando el instrumento entra en contacto con la encía.
- Evitar siempre los ladeos, no usar el disco como palanca.
- Se requiere refrigeración por agua.

Velocidad: 15.000 - 20.000 rpm.

Envase: 1 unidad

Tagliacorone Diasoft

- Disco diamantato sinterizzato per il taglio di corone e ponti.
- Se utilizzato in modo corretto, il disco rotante non provoca lesioni al tessuto molle grazie alla diamantatura sinterizzata.
- Evitare assolutamente angolazioni e non utilizzare il disco come leva.
- È necessario un raffreddamento ad acqua.

Velocità: 15' - 20000 giri/min.

Confezione: 1 unità

Diaflex mini

- Interdental corrections
- For ceramic and composites
- Intraoral application
- Avoid any contact with soft tissue, risk of injury!
- Water cooling needed

Speed: 3' - 5000 rpm.

Pu: single



943M

Diaflex mini
ISO 355



	L	0,1
S RA	Order-No	ø 1/10 mm
	204 943M ...	090
	P	6

Diaflex mini

- Corrections interdentaires
- Pour céramiques et composites
- Application intraorale
- Éviter tout contact avec des tissus mous, risque de lésion!
- Irrigation nécessaire

Vitesse : 3 - 5'000 tpm.

Conditionnement : 1 pièce

Diaflex mini

- Interdentale Korrekturen
- Für Keramik und Komposit
- Intraorale Anwendung
- Kontakt mit Weichgewebe unbedingt vermeiden, Verletzungsgefahr!
- Wasserkühlung erforderlich

Drehzahl: 3' - 5000 UpM.

VE: 1 Stück

Diaflex mini

- Correcciones interdenciales
- Para cerámica y resinas compuestas
- Aplicación intraoral
- Evitar el contacto con el tejido blando, peligro de lesiones
- Refrigeración por agua necesaria

Velocidad: 3.000 - 5.000 rpm.

Envase: 1 unidad

Diaflex mini

- Correzioni interdentali
- Per ceramica e compositi
- Applicazione intraorale
- Evitare assolutamente il contatto con il tessuto molle
- Raffreddamento ad acqua necessario

Velocità: 3' - 5000 giri/min.

Confezione: 1 unità

Swiss Goldies

Swiss Goldies diamonds differ from conventional diamonds in several aspects. First, the specially developed coating and embedding process achieves a density and homogeneity never seen before. Second, diamonds are set free for cutting in a controlled release process so that the cutting efficiency is maintained over a longer period of time. Finally, the diamond coating consists of several layers of all-natural diamonds with different grit sizes. Taken together, this new generation of Swiss Goldies diamonds contributes significantly to efficiency and comfort in your clinic.



Swiss Goldies

Les outils diamantés Swiss Goldies se distinguent en plusieurs aspects des outils diamantés traditionnels. D'une part, grâce à une technique de diamantage et de sertissage spéciale, on obtient une densité du revêtement diamanté plus forte et une durée de vie nettement plus élevée. D'autre part, les diamants sont dégagés non pas en une seule, mais en plusieurs étapes, afin de garantir une capacité de coupe constante et durable. Finalement, le diamantage se compose de diamants naturels de différents grains en plusieurs couches adaptées les unes aux autres. Au final, les instruments Swiss Goldies vous permettent un travail plus efficace et agréable.

Swiss Goldies

Die Swiss Goldies Diamantwerkzeuge unterscheiden sich in mehreren Aspekten von herkömmlichen Diamantwerkzeugen. Zum einen wird durch eine spezielle Beschichtungs- und Einbettungstechnik eine noch nie dagewesenen Dichte an Diamantbelag erreicht, was zu deutlich erhöhten Standzeiten führt. Zum zweiten werden die Diamanten nicht in einem Schritt, sondern stufenweise freigelegt, so dass eine möglichst konstante Schneidleistung über einen längeren Zeitraum gewährleistet ist. Schließlich besteht die Diamantierung aus ausgesuchten Naturdiamanten in mehreren, aufeinander abgestimmten Lagen unterschiedlicher Korngröße. In Summe tragen die Swiss Goldies wesentlich zu einem effizienten und angenehmen Arbeiten bei.

Swiss Goldies

Los instrumentos diamantados Swiss Goldies se diferencian en varios aspectos de los instrumentos diamantados habituales. Por un lado, gracias a una técnica especial de revestimiento e incrustación se consigue un recubrimiento de espesor único hasta el momento que ofrece una durabilidad notablemente superior. Y, por otro, la exposición de los diamantes no se realiza en un sólo paso sino de forma gradual, de modo que se garantiza una potencia de corte lo más constante posible durante un mayor periodo de tiempo. Además, el diamantado se compone de diamantes naturales seleccionados dispuestos en varias capas adaptadas entre sí y de diferente granulometría. Por eso, los Swiss Goldies permiten trabajar de un modo eficaz y agradable.

Swiss Goldies

Gli strumenti diamantati Swiss Goldies si differenziano per diversi aspetti dagli strumenti diamantati tradizionali. In primo luogo, grazie a una speciale tecnica di rivestimento e applicazione, si ottiene un eccezionale spessore del rivestimento in diamante, garantendo livelli di durata particolarmente elevati. In secondo luogo, i diamanti vengono consumati gradualmente, in modo da consentire prestazioni di taglio costanti per un periodo di tempo prolungato. Infine, il rivestimento consiste in pregiati diamanti naturali in diversi strati, collocati l'uno sull'altro, con grana di diverse dimensioni. In conclusione, gli Swiss Goldies contribuiscono in misura sostanziale a rendere più efficiente e gradevole il lavoro odontoiatrico.



SG 801

ISO 001

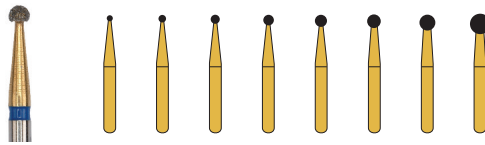

L		-							
S FG	Order-No	ø 1/10 mm							
D	314 S SG 801 ...	008	010	012	014	016	018	021	027
	314 G SG 801 ...		010	012	014	016	018	021	
P		3	3	3	3	3	3	4	4



SG 801 L

ISO 697

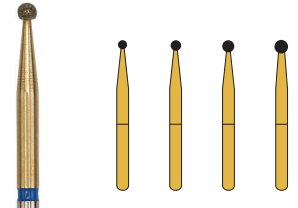

L		-			
S FG	Order-No	ø 1/10 mm			
D	314 S SG 801L ...	012	014	016	018
P		3	3	3	3



SG 805

ISO 010



L		1,5	1,5
S FG	Order-No	ø 1/10 mm	
D	314 S SG 805 ...	012	014
P		3	3



SG 807

ISO 225



L		5,0
S FG	Order-No	ø 1/10 mm
D	314 F SG 807 ...	018
	314 S SG 807 ...	018
	314 G SG 807 ...	018
P		3



SG 811

ISO 039



L		4,5
S FG	Order-No	ø 1/10 mm
D	314 S SG 811 ...	033
P		4



SG 830L

ISO 234



L		5,0	5,0
S FG	Order-No	ø 1/10 mm	
D	314 S SG 830L ...	014	
	314 G SG 830L ...	014	016
P		3	3



SG 830RL

ISO 238



L		3,0
S FG	Order-No	ø 1/10 mm
D	314 G SG 830RL ...	012
P		3



SG 835

ISO 109



L		4,0
S FG	Order-No	ø 1/10 mm
D	314 S SG 835 ...	010
P		3



SG 835KR

ISO 156



L		5,0
S FG	Order-No	ø 1/10 mm
D	314 S SG 835KR ...	012
	314 G SG 835KR ...	012
P		3



SG 837KR

ISO 158

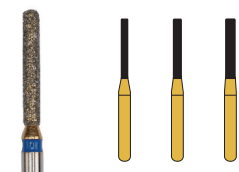

L		8,0	8,0	8,0
S FG	Order-No	ø 1/10 mm		
D	314 C SG 837KR ...	010		
	314 S SG 837KR ...	010	012	014
	314 G SG 837KR ...		012	014
P		3	3	3



SG 837ND

ISO 116



L	8,0
S FG	Order-No
D	314 S SG 837ND ... 016
P	3



SG 845KR

ISO 544



L	4,0	4,0
S FG	Order-No	ø 1/10 mm
D	314 S SG 845KR ... 018 025	
P	3	4



SG 847KR

ISO 269



L	8,0
S FG	Order-No
D	314 S SG 847KR ... 016
P	3



SG 848

ISO 173



L	10,0
S FG	Order-No
D	314 G SG 848 ... 014
P	3



SG 850

ISO 199

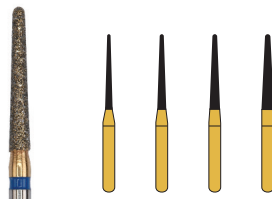

L	10,0	10,0	10,0	10,0	
S FG	Order-No	ø 1/10 mm			
D	314 C SG 850 ...	010	014	016	
	314 F SG 850 ...		012	014	
	314 S SG 850 ...	010	012	014	016
	314 G SG 850 ...	010	012	014	016
P		3	3	3	3



SG 852

ISO 164



L	6,0
S FG	Order-No
D	314 F SG 852 ... 012
	314 S SG 852 ... 012
	314 G SG 852 ... 012
P	3



SG 855

ISO 197



L	6,0	6,0
S FG	Order-No	ø 1/10 mm
D	314 S SG 855 ...	012 014
P	3	3



SG 856

ISO 198



L	8,0	8,0	8,0	
S FG	Order-No	ø 1/10 mm		
D	314 F SG 856 ...	016	018	021
	314 S SG 856 ...	016	018	021
	314 G SG 856 ...	016	018	021
P	3	3	4	



SG 858

ISO 165

= 6



L		8,0
S FG	Order-No	ø 1/10 mm
D	314 F SG 858 ...	014
	314 S SG 858 ...	014
	314 G SG 858 ...	014
P		3



SG 859

ISO 166

= 6



L		10,0	10,0
S FG	Order-No	ø 1/10 mm	
D	314 F SG 859 ...	010	018
	314 G SG 859 ...	010	018
P		3	3



SG 862

ISO 249

= 6



L		8,0
S FG	Order-No	ø 1/10 mm
D	314 S SG 862 ...	012
	314 G SG 862 ...	012
P		3



SG 863

ISO 250

= 6



L		10,0	10,0	10,0
S FG	Order-No	ø 1/10 mm		
D	314 C SG 863 ...	012		
	314 F SG 863 ...	012	014	016
	314 S SG 863 ...	012	014	016
	314 G SG 863 ...	012	014	016
P		3	3	3



SG 864

ISO 251

= 6

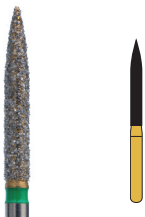

L		11,6
S FG	Order-No	ø 1/10 mm
D	314 F SG 864 ...	016
	314 S SG 864 ...	016
	314 G SG 864 ...	016
P		3



SG 878

ISO 289

= 6



L		8,0	8,0	8,0
S FG	Order-No	ø 1/10 mm		
D	314 F SG 878 ...	010	012	014
	314 S SG 878 ...	010	012	014
	314 G SG 878 ...	010	012	014
P		3	3	3



SG 878K

ISO 298

= 6

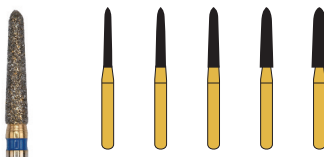

L		8,0	8,0	8,0	8,0	8,0
S FG	Order-No	ø 1/10 mm				
D	314 F SG 878K ...	018				
	314 S SG 878K ...	014	016			
	314 G SG 878K ...	014	016	018	020	022
P		3	3	3	4	4



SG 879

ISO 290

= 6



L		10,0	10,0	10,0
S FG	Order-No	ø 1/10 mm		
D	314 F SG 879 ...	012	014	016
	314 S SG 879 ...	012	014	016
	314 G SG 879 ...	012	014	016
P		3	3	3



SG 879K

ISO 299



		L				
		10,0	10,0	10,0	10,0	10,0
S FG	Order-No	ø 1/10 mm				
D	314 F SG 879K ...	014	016			
	314 S SG 879K ...	012				
	314 G SG 879K ...	012	014	016	018	021
P		3	3	3	3	4



SG 880

ISO 140

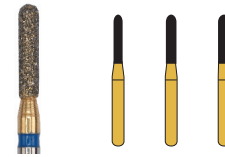

		L		
		6,5	6,5	6,5
S FG	Order-No	ø 1/10 mm		
D	314 F SG 880 ...	012	014	
	314 S SG 880 ...	012	014	
	314 G SG 880 ...	012	014	016
P		3	3	3



SG 881

ISO 141



		L		
		8,5	8,5	8,5
S FG	Order-No	ø 1/10 mm		
D	314 F SG 881 ...	014	016	
	314 S SG 881 ...	012	014	016
	314 G SG 881 ...	012	014	016
P		3	3	3



SG 889

ISO 540

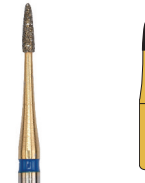

		L	
		3,9	
S FG	Order-No	ø 1/10 mm	
D	314 C SG 889 ...	009	
	314 S SG 889 ...	009	
P		3	



SG 909

ISO 068



		L	
		1,0	
S FG	Order-No	ø 1/10 mm	
D	314 S SG 909 ...	037	
P		4	



SG 368

ISO 257



		L	
		4,0	5,0
S FG	Order-No	ø 1/10 mm	
D	314 C SG 368 ...	023	
	314 F SG 368 ...	018	023
	314 S SG 368 ...	018	023
	314 G SG 368 ...	018	023
P		3	4



SG 379

ISO 277



		L	
		5,5	
S FG	Order-No	ø 1/10 mm	
D	314 F SG 379 ...	023	
	314 S SG 379 ...	023	
	314 G SG 379 ...	023	
P		4	

Porcelain Veneer Set

P: 364

S: FG



Crown Cutter Set

P: 361

S: RA/FG

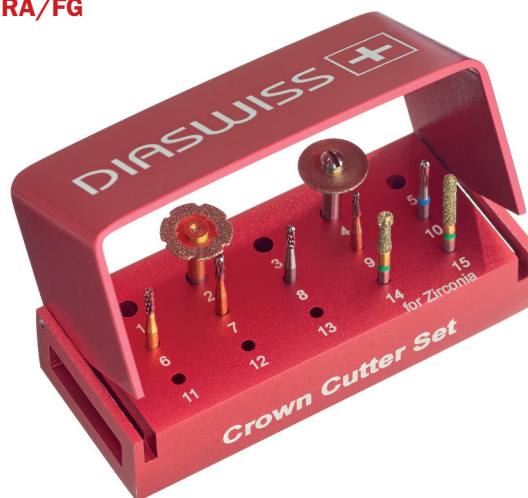

F	834RD	837RD	856	856L	859	852	379
S	FG	FG	FG	FG	FG	FG	FG
∅	018	016	023	023	014	014	018
D	G		SG		C	C	C
P	4	4	2	2	1	1	1
Order-No	314 GRD 834 018	314 RD 837 016	314 SG 856 023	314 856L 023	314 C 859 014	314 C 852 014	314 C 379 018

F	943	943S	21X	21RX	21SC	23RX	36R	881Z	389T
S	RA	RA	FG	FG	FG	FG	FG	FG	FG
∅	090	090	012	012	012	012	012	016	021
D								G	G
P	7	8	37	37	37	37	36	5	5
Order-No	204 943 090	204 943S 090	314 021X 012	314 021RX 012	314 021SC 012	314 023RX 012	314 036R 012	314 G 881Z 016	314 G 389T 021

Prep Set

P: 365

S: FG



F	811	848	848	850	858	859	863	863	878	879
S	FG	FG	FG	FG	FG	FG	FG	FG	FG	FG
∅	033	012	016	014	012	012	012	016	012	012
D			G							
P	4	1	1	1	1	1	1	1	1	1
Order-No	314 811 033	314 848 012	314G 848 016	314 850 014	314 858 012	314 859 012	314 863 012	314 863 016	314 878 012	314 879 012

Cavity Access Set

P: 362

S: FG



F	1	1	7	152	2	801	802	830	835KR	851
S	FG	FG	FG	FG	FG	FG	FG	FG	FG	FG
∅	014	014	012	015	012	012	012	012	012	012
D										
P	31	33	31	81	31	1	1	1	1	1
Order-No	314 001 014	316 001 014	314 007 012	316C 152 015	314 002 012	314 801 012	314 802 012	314 830 012	314 835KR 012	314 851 012

Orthodontic Set

P: 369

S: RA/FG



F	44E	194	030	304	243	44E	135	247UF	44EUF	48UF	851	862	852	379	858
S	RA	RA	RA	RA	RA	FG	FG	FG	FG	FG	FG	FG	FG	FG	FG
∅	018	016	033	065	100	014	014	012	018	012	012	F	F	C	C
D															
P	34	83	70	71	72	34	34	35	35	35	1	1	1	1	1
Order-No	204 044E 018	204 C 194 016	110RA	111RA	112RA	314 044E 014	314 135 014	314 247UF 012	314 044EUF 018	314 048UF 012	314 F 851 012	314 F 862 012	314 C 852 012	314 C 379 014	314 C 858 012

Cavity Set

P: 365

S: FG

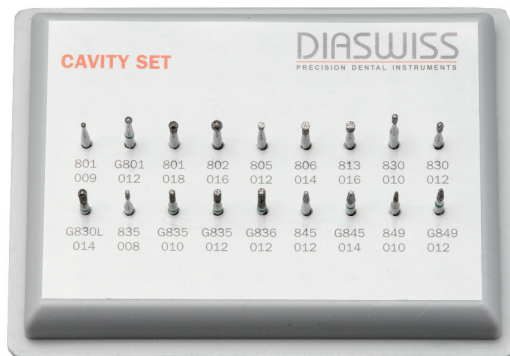

F	801	801	801	802	805	806	813	830	830	830L	835	835	835	836	845	845	849	849
Ø 1/10mm	009	012	018	016	012	014	016	010	012	014	008	010	012	012	012	014	010	012
D		G								G		G	G	G		G		G
P	1	1	1	1	1	1	1	1	1	1	1	1	1	1	1	1	1	1
Order-No	314 801 009	314 G 801 012	314 801 018	314 802 016	314 805 012	314 806 014	314 813 016	314 830 010	314 830 012	314 G 830L 014	314 835 008	314 G 835 010	314 G 835 012	314 G 836 012	314 845 012	314 G 845 014	314 849 010	314 G 849 012

Preparation Set

P: 364

S: FG

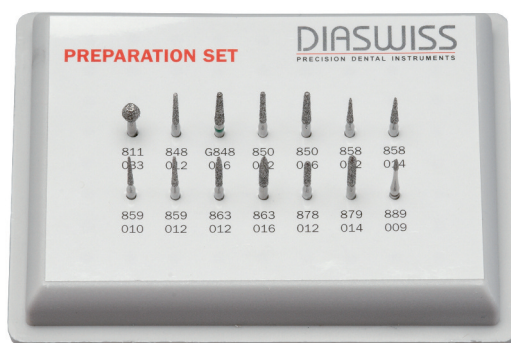

F	811	848	848	850	850	858	858	859	859	863	863	878	879	889
Ø	033	012	016	012	016	012	014	010	012	012	016	012	014	009
D			G											
P	4	3	3	3	3	3	3	3	3	3	3	2	3	1
Order-No	314 811 033	314 848 012	314 G 848 016	314 850 012	314 850 016	314 858 012	314 858 014	314 859 010	314 859 012	314 863 012	314 863 016	314 878 012	314 879 014	314 889 009

Crown Prep Set
allceramics with guide pin
P: 367
S: FG



Crown Prep Set
zirconia with guide pin
P: 368
S: FG



F	856	801	850	856	856
∅	014	018	020	020	020
D	SG	SG	SG	SG	F
P	3	1	4	4	4

Order-No	314 SGP 856 014	314 801 018	314 SGP 850 020	314 SGP 856 020	314 FP 856 020
-----------------	-----------------	-------------	-----------------	-----------------	----------------

F	856	801	850Z	856	856
∅	014	014	016	018	018
D	SG	SG	SG	SG	F
P	3	1	3	3	3

Order-No	314 SGP 856 014	314 801 014	314 SGP 850Z 016	314 SGP 856 018	314 FP 856 018
-----------------	-----------------	-------------	------------------	-----------------	----------------

Micro Prep Set
for minimally invasive
preparation technique
P: 362
S: FG



F	801	802	830	830	838	889	368	890	801	802	830	830	838	889	368	890
∅	009	014	009	012	007	007	012	014	009	014	009	012	007	007	012	014
D	SG	SG	SG	SG	SG	SG	SG	SG	F	F	F	F	F	F	F	F
P	2	2	2	2	2	2	2	2	2	2	2	2	2	2	2	2

Order-No	314 MP801 009	314 MP802 014	314 MP830 009	314 MP830 012	314 MP838 007	314 MP889 007	314 MP368 012	314 MP890 014	314 MPF801 009	314 MPF802 014	314 MPF830 009	314 MPF830 012	314 MPF838 007	314 MPF889 007	314 MPF368 012	314 MPF890 014
-----------------	---------------	---------------	---------------	---------------	---------------	---------------	---------------	---------------	----------------	----------------	----------------	----------------	----------------	----------------	----------------	----------------

Finishing Set

P: 366

S: **FG**



F	801	852	858	859	862	368	801	852	858	859	862	368
∅	014	010	014	016	014	023	014	010	014	016	014	023
D	F	F	F	F	F	F	C	C	C	C	C	C
P	1	1	1	1	1	2	1	1	1	1	1	2
Order-No	314 F 801 014	314 F 852 010	314 F 858 014	314 F 859 016	314 F 862 014	314 F 368 023	314 C 801 014	314 C 852 010	314 C 858 014	314 C 859 016	314 C 862 014	314 C 368 023

Perio Set (RA)

P: 363

S: **RA**



F	832	831	832L	831L	832	831	832L	831L	832	831	832L	831L
S	RA	RA	RA	RA	RA	RA	RA	RA	RA	RA	RA	RA
∅	014	012	014	012	014	012	014	012	014	012	014	012
D	F	F	F	F	F	F	F	F	C	C	C	C
P	4	4	4	4	4	4	4	4	4	4	4	4
Order-No	205 832 014	205 831 012	205 832L 014	205 831L 012	205 F 832 014	205 F 831 012	205 F 832L 014	205 F 831L 012	205 C 832 014	205 C 831 012	205 C 832L 014	205 C 831L 012

Diacarb Carbide burs

Diacarb carbide burs are a winning solution for all clinical applications. The burs are characterized by an outstanding cutting efficiency, true running accuracy and long lifetime helping you to achieve optimum results. The range of shapes and cutting geometries allows you to avoid frequent instrument change thereby saving time and money.

Shank information

ISO 314 FG standard

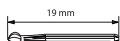

ISO 313 FG short

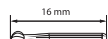

ISO 316 FG XL



ISO 204 right angle

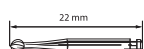

Order-No

You will find the order number in each product segment, please use this order number plus the required diameter. Alternatively, you may also use the ISO-number for the shape plus the shank and diameter information.

Packaging

Diacarb carbide burs are packed as 6 pcs.

Maximum recommended speed

FG head diameter up to 018	300.000 rpm
FG head diameter up to 023	200.000 rpm
FG head diameter up to 027	120.000 rpm
RA/HP head diameter up to 023	30.000 rpm
RA/HP head diameter 025 and greater	20.000 rpm

Instruments en carbure de tungstène Diacarb

La gamme d'instruments en carbure offre des solutions pour toutes les applications odontologiques. Les instruments Diacarb se distinguent de par leur excellente capacité de coupe, leur durée de vie prolongée ainsi que leur parfaite concentricité. Ils vous permettent d'obtenir des résultats optimaux. Le choix des formes et des dentures adaptées vous permet d'éviter les changements fréquents d'instrument, afin de travailler efficacement, tout en réalisant de réels gains de temps.

Longueurs de tige

ISO 314 FG standard

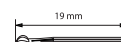

ISO 313 FG courte

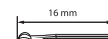

ISO 316 FG XL



ISO 204 Contre-angle



Référence

La référence est indiquée pour chaque article en anglais («Order-No.»). Veuillez s'il vous plaît indiquer à la commande cette référence ainsi que le diamètre. Au lieu de la référence, vous pouvez aussi indiquer dans votre commande le code ISO de la forme de la tête, la tige et le diamètre.

Conditionnement

Les instruments en carbure Diacarb sont conditionnés par 6.

Vitesses recommandées pour les instruments en carbure :

FG diamètre de la tête jusqu'à 018	300'000 tpm
FG diamètre de la tête jusqu'à 023	200'000 tpm
FG diamètre de la tête jusqu'à 027	120'000 tpm
CA/PM diamètre de la tête jusqu'à 023	30'000 tpm
CA/PM diamètre de la tête à partir de 025	20'000 tpm

Diacarb Hartmetallwerkzeuge

Das Sortiment an Hartmetallwerkzeugen bietet überzeugende Lösungen für alle zahnmedizinischen Anwendungen. Diacarb Werkzeuge zeichnen sich durch hohe Schneidfrequenz, lange Standzeit und hohe Rundlaufgenauigkeit aus und helfen Ihnen, optimale Arbeitsergebnisse zu erzielen. Das abgestimmte Sortiment an Formen und Verzahnungen vermeidet häufige Instrumentenwechsel und führt zu einer zeitsparenden und effizienten Arbeitsweise.

Schaftlängen

ISO 314 FG Standard

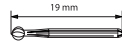

ISO 313 FG short



ISO 316 FG XL

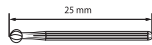

ISO 204 Winkelstück



Bestellnummer

Die Bestellnummer ist als „Order-No.“ bei jedem Artikel angegeben, bitte verwenden Sie diese Bestellnummern inkl. der Durchmesserangabe. Alternativ können Sie unter Angabe der ISO-Kopfform, Schaft und Durchmesser bestellen.

Verpackung

Diacarb Hartmetallwerkzeuge werden zu 6 Stück verpackt.

Maximale Drehzahlen für Hartmetallwerkzeuge:

FG Kopfdurchmesser bis 018	300.000 UpM
FG Kopfdurchmesser bis 023	200.000 UpM
FG Kopfdurchmesser bis 027	120.000 UpM
WST/HST Kopfdurchmesser bis 023	30.000 UpM
WST/HST Kopfdurchmesser ab 025	20.000 UpM

Instrumentos de carburo de tungsteno Diacarb

La gama de instrumentos de carburo de tungsteno ofrece soluciones para todas las indicaciones odontológicas. Los instrumentos Diacarb se destacan por su elevado rendimiento de corte, su larga durabilidad y su alta precisión de concentricidad, por eso le ayudan a conseguir unos resultados óptimos. El surtido adaptado de formas y dentados evita el cambio frecuente de los instrumentos y permite trabajar de un modo eficaz y rápido.

Longitudes de vástago

ISO 314 FG Standard

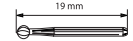

ISO 313 FG short

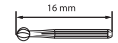

ISO 316 FG XL

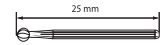

ISO 204 Contraángulo



Número de pedido

El número de pedido aparece indicado en todos los artículos como “Order-No.”. Por favor, utilice este número junto con la indicación del diámetro. Alternativamente puede hacer su pedido indicando la forma de la cabeza ISO, el vástago y el diámetro.

Envase

Los instrumentos de carburo de tungsteno de Diacarb se suministran en envases de 6 unidades.

Velocidades máximas para los instrumentos de carburo de tungsteno:

FG diámetro de cabeza hasta 018	300.000 rpm
FG diámetro de la cabeza hasta 023	200.000 rpm
FG diámetro de cabeza hasta 027	120.000 rpm
CA/PM diámetro de cabeza hasta 023	30.000 rpm
CA/PM diámetro de cabeza a partir de 025	20.000 rpm

Strumenti in carburo di tungsteno Diacarb

L'assortimento di strumenti in carburo di tungsteno offre soluzioni per tutte le applicazioni odontoiatriche. Gli strumenti Diacarb si distinguono per l'elevata efficienza di taglio, la lunga durata utile e l'ottima concentricità, e consentono di ottenere risultati di lavorazione ottimali. L'assortimento coordinato di forme e tagli permette di evitare una frequente sostituzione dello strumento e di ottenere una lavorazione rapida ed efficiente.

Lunghezza del gambo

ISO 314 FG standard

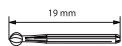

ISO 313 FG short

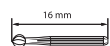

ISO 316 FG XL

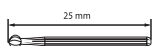

ISO 204 contrangolo



Numero d'ordine

Il numero d'ordine è indicato con "Order-No." per ogni articolo. Per ordini si prega di utilizzare questo numero più l'indicazione del diametro. In alternativa è possibile effettuare ordini indicando la forma della testa ISO, il gambo e il diametro.

Confezione

Gli strumenti in carburo di tungsteno Diacarb sono in confezioni da 6 pezzi.

Velocità massime per gli strumenti in carburo di tungsteno:

FG diametro testa fino a 018	300.000 giri/min
FG Diametro testa fino a 023	200.000 giri/min
FG diametro testa fino a 027	120.000 giri/min
WST/HST diametro testa fino a 023	30.000 giri/min
WST/HST diametro testa fino a 025	20.000 giri/min

ISO codification

The ISO codification consists of 15 digits in 5 groups:

Code ISO

Le code ISO est composé de 15 chiffres répartis en cinq groupes :

ISO-Nummernaufbau

Die ISO-Kodifizierung besteht aus 15 Ziffern, welche in 5 Teilblöcke eingeteilt sind:

Composición del número ISO

La codificación ISO se compone de 15 cifras, divididas en 5 bloques:

Struttura del numero ISO

La codifica ISO è costituita da 15 cifre, suddivise in 5 blocchi:

500

314

001

006

012

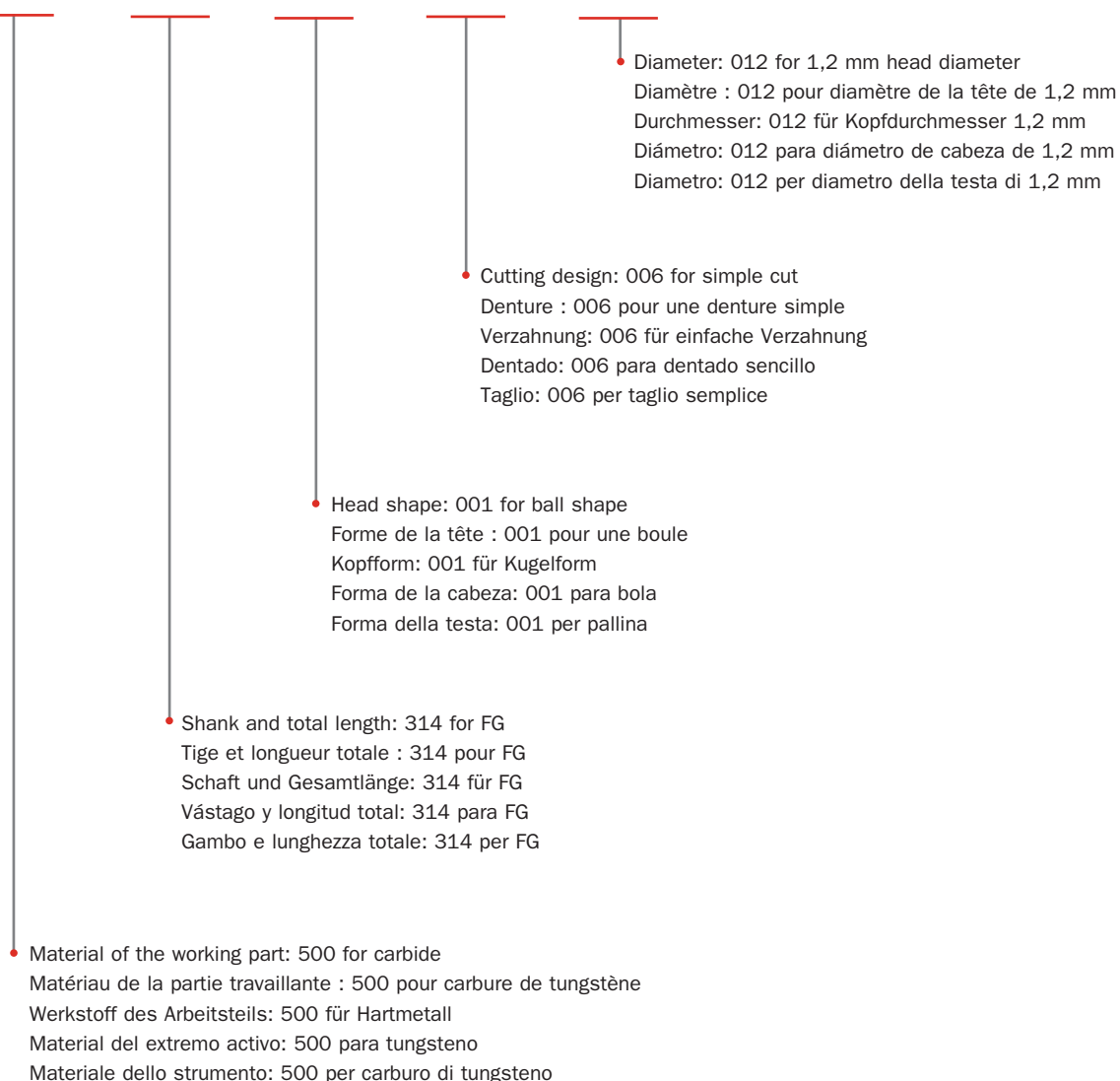

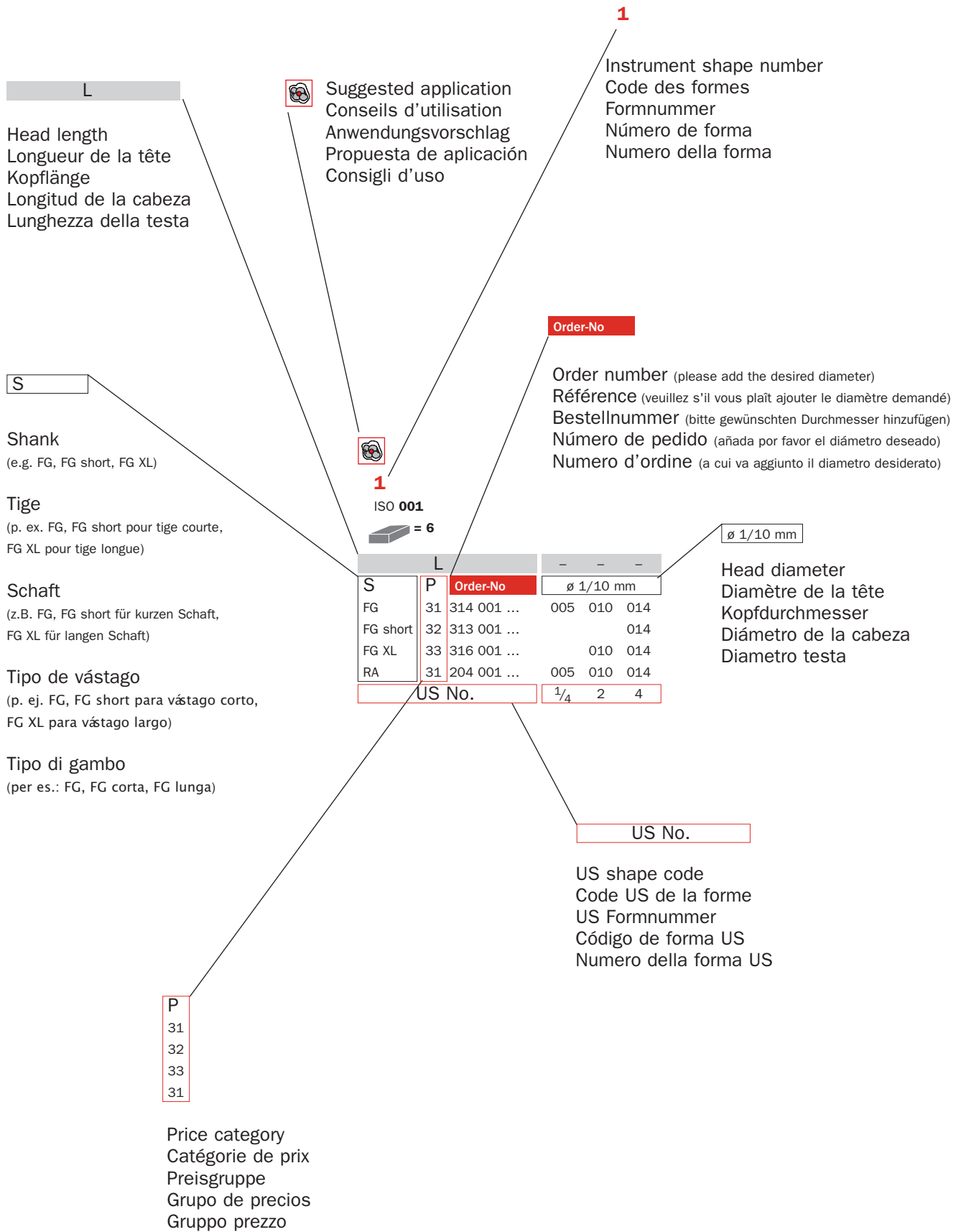



1

ISO 001

= 6



L		ø 1/10 mm												
S	P	Order-No												
FG	31	314 001 ...	005	006	008	010	012	014	016	018	021	023		
FG XL	33	316 001 ...				010	012	014	016	018		023		
RA	31	204 001 ...	005	006	008	010	012	014	016	018	021	023	027	
US No.			1/4	1/2	1	2	3	4	5	6	7	8	10	



1L

ISO 001

= 6



L		ø 1/10 mm					
S	P	Order-No					
RA	33	204 001L ...	010	012	014	016	018
US No.			2	3	4	5	6



1LQ

ISO 697

= 6

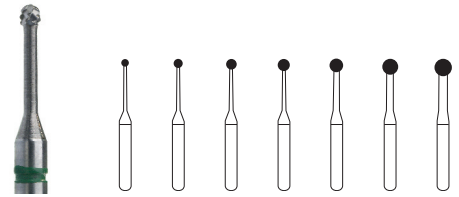

L		ø 1/10 mm							
S	P	Order-No							
RA	33	204 001LQ ...	010	012	014	016	018	021	023
RA	33	205 001LQ ...	010	012	014	016	018	021	
US No.									



2

ISO 010

= 6

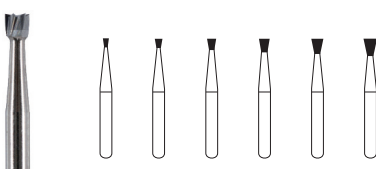

L		ø 1/10 mm						
S	P	Order-No	1,2	1,2	1,5	1,8	2,0	2,3
FG	31	314 002 ...	008	010	012	014	016	018
RA	31	204 002 ...	008	010	012	014	016	018
US No.			34	35	36	37	38	39



7

ISO 237

= 6

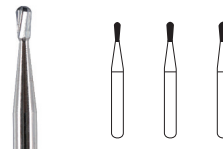

L		ø 1/10 mm			
S	P	Order-No	2,5	2,5	2,5
FG	31	314 007 ...	008	010	012
FG short	32	313 007 ...	008		
RA	31	204 007 ...	008	010	012
US No.			330	331	332



21

ISO 107

= 6

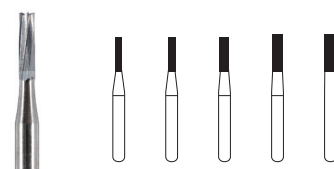

L		ø 1/10 mm					
S	P	Order-No	4,0	4,5	4,5	5,0	5,0
FG	31	314 021 ...	009	010	012	014	016
FG XL	33	316 021 ...			012		
RA	31	204 021 ...	009	010	012		
US No.			56	57	58	59	60



21L

ISO 110

= 6



L		ø 1/10 mm		
S	P	Order-No	6,0	6,0
FG	31	314 021L ...	010	012
US No.			57L	58L



21R

ISO 137

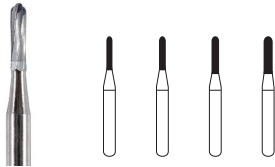

		L	4,5	4,5	5,0	5,0
S	P	Order-No	ø 1/10 mm			
FG	31	314 021R ...	009	010	012	
RA	31	204 021R ...	008	010		
		US No.	1156	1156	1157	1158



23

ISO 168

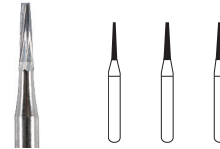

		L	5,0	5,0	5,0
S	P	Order-No	ø 1/10 mm		
FG	31	314 023 ...	008	010	012
		US No.	169	170	171



23L

ISO 171



		L	5,5	5,5	5,5
S	P	Order-No	ø 1/10 mm		
FG	31	314 023L ...	009	010	012
RA	31	204 023L ...	009		
		US No.	169L	170L	171L



23R

ISO 194

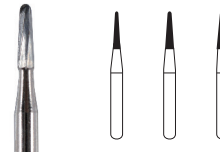

		L	5,0	5,0	5,0
S	P	Order-No	ø 1/10 mm		
FG	31	314 023R ...	010	012	016
RA	31	204 023R ...	012	016	
		US No.	1170	1171	1172



25R

ISO 238

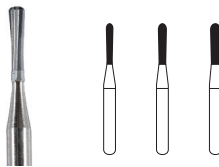

		L	5,5	5,5	5,5
S	P	Order-No	ø 1/10 mm		
FG	31	314 025R ...	010	012	014
RA	31	204 025R ...	012		
		US No.	331L	332L	333L



31

ISO 109

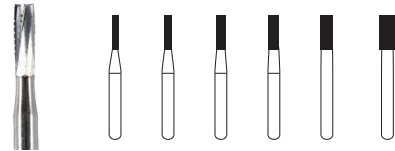

		L	4,5	4,5	4,5	4,5	4,5	4,5
S	P	Order-No	ø 1/10 mm					
FG	31	314 031 ...	008	010	012	014	016	
FG XL	33	316 031 ...		010	012			
RA	31	204 031 ...	008	010	012	014		021
		US No.	556	557	558	559	560	562



31L

ISO 110



		L	6,0	6,0
S	P	Order-No	ø 1/10 mm	
FG	31	314 031L ...	010	012
RA	31	204 031L ...	012	
		US No.	557L	558L



31R

ISO 137

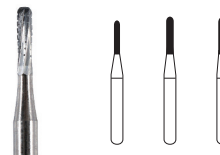

		L	4,5	5,0	5,0
S	P	Order-No	ø 1/10 mm		
FG	31	314 031R ...	008	010	012
RA	31	204 031R ...	010		
		US No.	1556	1557	1558



33
ISO 168

= 6

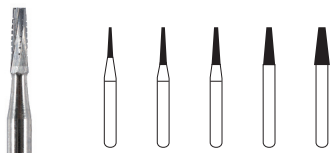

L			4,0	5,0	5,0	5,0	5,0
S	P	Order-No	ø 1/10 mm				
FG	31	314 033 ...	008	010	012	016	021
FG XL	33	316 033 ...			012	016	
RA	31	204 033 ...				016	
US No.			699	700	701	702	703



33L
ISO 171

= 6



L			5,5	5,5	6,0
S	P	Order-No	ø 1/10 mm		
FG	31	314 033L ...	008	010	012
US No.			699L	700L	701L



33R
ISO 194

= 6

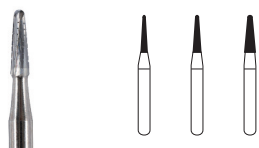

L			5,0	5,0	5,0
S	P	Order-No	ø 1/10 mm		
FG	31	314 033R ...	010	012	016
US No.			1700	1701	1702



1RX
ISO 001

= 6



L			-
S	P	Order-No	ø 1/10 mm
FG	34	314 001RX ...	014
US No.			1904



31RX
ISO 109

= 6



L			4,5
S	P	Order-No	ø 1/10 mm
FG	34	314 031RX ...	009
US No.			2056

Finishing burs | Fraises de finition | Finierer | Fresas para acabado | Frese per la finitura



41

Finishing bur 12 flutes
ISO 001

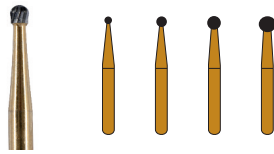

L		-			
S	P	Order-No	ø 1/10 mm		
FG	34	314 041 ...	012	014	018 023
US No.		7002 7004 7006 7008			



44E

Finishing bur 12 flutes
ISO 277

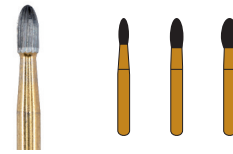

L		3,5 4,0 4,0			
S	P	Order-No	ø 1/10 mm		
FG	34	314 044E ...	014	018 023	
RA	34	204 044E ...	018		
US No.		7404 7406 7408			



46

Finishing bur 12 flutes
ISO 254

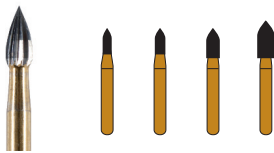

L		3,5 3,5 4,0 5,0			
S	P	Order-No	ø 1/10 mm		
FG	34	314 046 ...	012	014	018 023
US No.		7103 7104 7106 7108			



47L

Finishing bur 12 flutes
ISO 236



L		5,0	
S	P	Order-No	ø 1/10 mm
FG	34	314 047L ...	014
US No.		7304	



48

Finishing bur 12 flutes
ISO 246

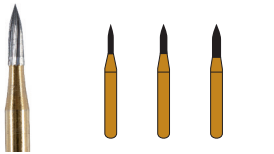

L		4,0 4,0 4,5			
S	P	Order-No	ø 1/10 mm		
FG	34	314 048 ...	008	010 012	
US No.		7901 7902 7903			



132

Finishing bur 12 flutes
ISO 182



L		4,0	
S	P	Order-No	ø 1/10 mm
FG	34	314 132 ...	008
US No.		7114	



133

Finishing bur 12 flutes
ISO 217



L		6,0	
S	P	Order-No	ø 1/10 mm
FG	34	314 133 ...	010
US No.		7214	



135

Finishing bur 12 flutes
ISO 184



L		9,5	
S	P	Order-No	ø 1/10 mm
FG	34	314 135 ...	014
US No.		7714	



212

Finishing bur 12 flutes
ISO 168



		L	5,5	5,5
S	P	Order-No	ø 1/10 mm	
FG	34	314 212 ...	010	012
US No.		7702 7713		



212L

Finishing bur 12 flutes
ISO 184



		L	9,5	9,5	9,5
S	P	Order-No	ø 1/10 mm		
FG	34	314 212L ...	014	016	018
US No.		7204 7205 7206			



247

Finishing bur 12 flutes
ISO 499

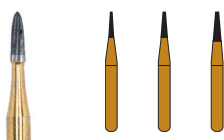

		L	3,5	3,5	4,0
S	P	Order-No	ø 1/10 mm		
FG	34	314 247 ...	008	010	012
US No.		7801 7802 7803			



212UF

Finishing bur 30 flutes
ISO 182



		L	5,5
S	P	Order-No	ø 1/10 mm
FG	35	314 212UF ...	012
US No.		9713	



247UF

Finishing bur 30 flutes
ISO 499



		L	4,0
S	P	Order-No	ø 1/10 mm
FG	35	314 247UF ...	012
US No.		9803	



44E UF

Finishing bur 30 flutes
ISO 277



		L	4,0
S	P	Order-No	ø 1/10 mm
FG	35	314 044EUF ...	018
US No.		9406	



48UF

Finishing bur 30 flutes
ISO 247



		L	6,0	6,0
S	P	Order-No	ø 1/10 mm	
FG	35	314 048UF ...	012	014
US No.		9903 9904		

Crown cutters | Coupe couronnes | Kronentrenner | Cortadores de corona | Tagliacorone



17

Crown cutter

ISO **237**

= 6



L		2,3
S	P	Order-No
FG	36	314 017 ...
US No.		1931



- Non-precious and precious alloys
- Alliages non-précieux et précieux
- Nichtedelmetall, Edelmetall
- Aleaciones no preciosas y preciosas
- Metallo nobile e non nobile



21X

Crown cutter

ISO **107**

= 6



L		4,0	4,5
S	P	Order-No	ø 1/10 mm
FG	37	314 021X ...	010 012
US No.		557X 558X	



- PFM crowns, non-precious and precious alloys, titanium
- Couronnes céramo-métalliques, alliages non-précieux et précieux, titane
- VMK-Kronen, Nichtedelmetall, Edelmetall, Titan
- Coronas de porcelana fundida sobre metal, aleaciones no preciosas y preciosas, titanio
- Corona in metallo-ceramica, metallo nobile e non nobile, titanio



21RX

Crown cutter

ISO **137**

= 6



L		4,5	4,5
S	P	Order-No	ø 1/10 mm
FG	37	314 021RX ...	010 012
US No.		557RX 558RX	



- PFM crowns, non-precious and precious alloys, titanium
- Couronnes céramo-métalliques, alliages non-précieux et précieux, titane
- VMK-Kronen, Nichtedelmetall, Edelmetall, Titan
- Coronas de porcelana fundida sobre metal, aleaciones no preciosas y preciosas, titanio
- Corona in metallo-ceramica, metallo nobile e non nobile, titanio



21SC

Crown cutter

ISO **139**

= 6

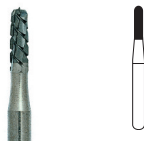

L		4,5
S	P	Order-No
FG	37	314 021SC ...
US No.		58RX

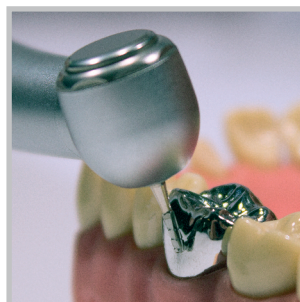

- Non-precious and precious alloys, titanium, composites
- Alliages non-précieux et précieux, titane, composites
- Nichtedelmetall, Edelmetall, Titan, Komposite
- Aleaciones no preciosas y preciosas, titanio, resinas compuestas
- Metallo nobile e non nobile, titanio, composite



23X

Crown cutter

ISO **168**

= 6



L		4,0	4,5
S	P	Order-No	ø 1/10 mm
FG	37	314 023X ...	010 012
US No.		700X 701X	



- PFM crowns, non-precious and precious alloys, titanium
- Couronnes céramo-métalliques, alliages non-précieux et précieux, titane
- VMK-Kronen, Nichtedelmetall, Edelmetall, Titan
- Coronas de porcelana fundida sobre metal, aleaciones no preciosas y preciosas, titanio
- Corona in metallo-ceramica, metallo nobile e non nobile, titanio

- PFM crowns, non-precious and precious alloys, titanium
- Couronnes céramo-métalliques, alliages non-précieux et précieux, titane
- VMK-Kronen, Nichtedelmetall, Edelmetall, Titan
- Coronas de porcelana fundida sobre metal, aleaciones no preciosas y preciosas, titanio
- Corona in metallo-ceramica, metallo nobile e non nobile, titanio



23RX

Crown cutter
ISO **194**

= 6



L		4,5	4,5
S	P	Order-No	∅ 1/10 mm
FG	37	314 023RX ...	010 012
US No.		700RX 701RX	

- Non-precious and precious alloys, titanium, composites
- Alliages non-précieux et précieux, titane, composites
- Nichtedelmetall, Edelmetall, Titan, Komposite
- Aleaciones no preciosas y preciosas, titanio, resinas compuestas
- Metallo nobile e non nobile, titanio, composite



23SC

Crown cutter
ISO **196**

= 6



L		4,5	
S	P	Order-No	∅ 1/10 mm
FG	37	314 023SC ...	012
US No.		71RX	

- PFM crowns, non-precious and precious alloys
- Couronnes céramo-métalliques, alliages non-précieux et précieux
- VMK-Kronen, Nichtedelmetall, Edelmetall
- Coronas de porcelana fundida sobre metal, aleaciones no preciosas y preciosas
- Corona in metallo-ceramica, metallo nobile e non nobile



25CC

ISO **196**

= 6



L		3,5	3,5
S	P	Order-No	∅ 1/10 mm
FG	37	314 025CC ...	012 014
US No.		701SX 702SX	

- Non-precious and precious alloys, composites
- Alliages non-précieux et précieux, composites
- Nichtedelmetall, Edelmetall, Komposite
- Aleaciones no preciosas y preciosas, resinas compuestas
- Metallo nobile e non nobile, composite



36R

Crown cutter
ISO **137**

= 6



L		4,3	
S	P	Order-No	∅ 1/10 mm
FG	36	314 036R ...	012
US No.		1958	

Orthodontic carbide bur

Fraise orthodontique

KFO-Entferner

Removedor de ortodoncia

Per rimuovere i lavori di ortodonzia



C 194

ISO **194**

= 6



L		5,0
S	Order-No	∅ 1/10 mm
RA	204 C 194 ...	016
P		83

Polishers

The Diaswiss polisher range covers all clinical polishing needs. The tools are manufactured using the most recent production techniques and carefully selected polishing materials. These tools allow you to work fast and efficiently, delivering superb polishing results in terms of surface quality and shine. The selected geometries cover all relevant applications.

The recommended speed is indicated in each product segment under the polisher name, in addition, we provide the ISO code information regarding the head shape.

Order-No

The order number is indicated for each article. Alternatively, you may also order by giving the polisher name, the ISO shape number, the diameter and the polishing step.

Packaging unit

The packaging unit (VE) is indicated for each article.

Polissoirs

La gamme de polissoirs de Diaswiss comprend des instruments pour toutes les applications courantes. Elle est réalisée dans les matériaux les plus modernes et selon des procédés de fabrication à la pointe du progrès. Ceci permet de travailler efficacement et ainsi d'obtenir d'excellents résultats.

La vitesse de rotation est indiquée pour chaque segment sous le nom du produit. Le code ISO de la forme est également indiqué pour chaque article.

Référence

La référence est indiquée pour chaque article en anglais («Order-No.»). Veuillez s'il vous plaît toujours utiliser ces références. Au lieu de la référence, vous pouvez aussi indiquer dans votre commande le nom du polissoir, le code ISO de la forme de la tête, le diamètre et l'étape de polissage.

Conditionnement

L'unité d'emballage (VE) est indiquée pour chaque article.

Polierer

Das Poliererprogramm von Diaswiss umfasst Instrumente für alle gängigen Anwendungen. Hinsichtlich Ausführung wurden modernste Materialien und Herstellungsverfahren gewählt, die ein effizientes Arbeiten und ausgezeichnete Polierergebnisse ermöglichen. Die ausgewählten Geometrien decken alle relevanten Polierfälle ab.

Die Drehzahlangabe befindet sich in jedem Produktsegment unterhalb des Produktnamens, die ISO-Nummer der Form ist ebenfalls bei jedem Artikel angegeben.

Bestellnummer

Die Bestellnummer ist als „Order-No.“ bei jedem Artikel angegeben, bitte verwenden Sie stets diese Bestellnummern. Alternativ können Sie unter Angabe des Namens, der ISO-Kopfform, des Durchmessers und der Polierstufe bestellen.

Verpackung

Die Verpackungseinheit (VE) ist bei jedem Artikel angegeben.

Pulidores

El programa de pulidores de Diaswiss incluye instrumentos para todas las indicaciones importantes. Para su fabricación se han empleado materiales y procesos de fabricación de última generación que permiten trabajar con eficacia y obtener unos resultados de pulido excelentes. Las geometrías seleccionadas cubren todos los casos de pulido importantes.

En cada segmento de producto, la velocidad aparece indicada debajo del nombre del producto. El número ISO de la forma también está señalado en cada artículo.

Número de pedido

El número de pedido aparece indicado en todos los artículos como "Order-No.". Por favor, utilice siempre este número. Alternativamente puede realizar el pedido indicando el nombre, la forma de la cabeza ISO, el diámetro y la fase de pulido.

Envase

La unidad de envasado (VE) aparece indicada en cada artículo.

Gommini

Il programma di strumenti per lucidatura da Diaswiss include strumenti per tutte le applicazioni più comuni. Per quanto concerne l'esecuzione sono stati selezionati i materiali e i processi produttivi più all'avanguardia per ottenere un'efficiente lavorazione e ottimi risultati di lucidatura. Le geometrie selezionate coprono tutti i casi di lucidatura.

La velocità di lavorazione di ogni segmento di prodotti è indicata sotto al nome del prodotto. Per ogni articolo è indicato anche il numero ISO della forma.

Numero d'ordine

Il numero d'ordine è indicato con "Order-No." per ogni articolo. Per ordinazioni si prega di utilizzare sempre questo numero. In alternativa è possibile effettuare ordini indicando il nome, la forma della testa ISO, il diametro e il livello di lucidatura.

Confezione

L'unità di pezzi (VE) è indicata per ogni articolo.

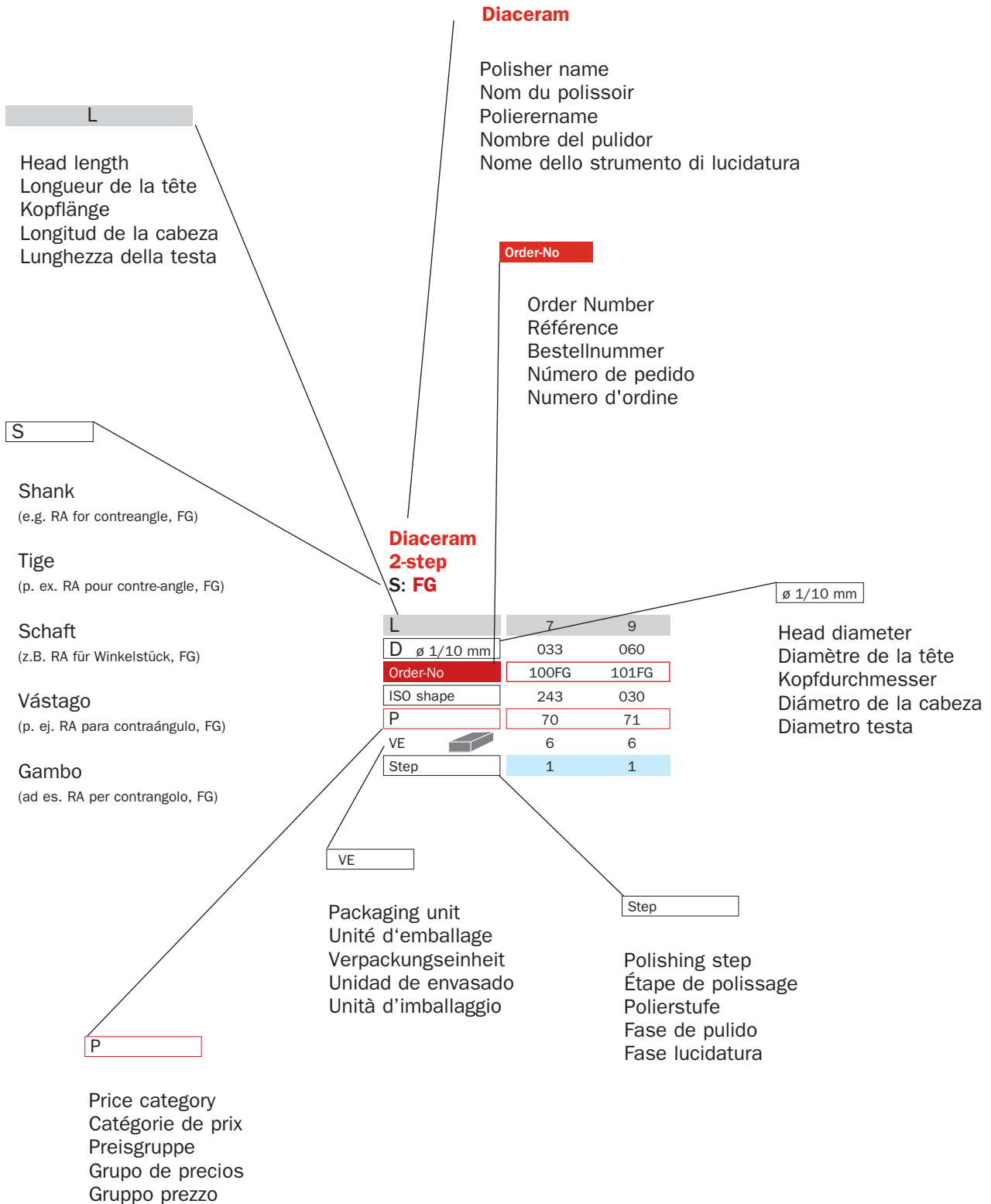

Diaceram 2-step

Polishing system for all ceramics in 2 steps. Diamond-impregnated polishers for polishing, finishing and high-shine.

Diaceram 2-step

Système de polissage en deux étapes pour toutes les céramiques courantes. Polissoirs diamantés pour le polissage, la finition et la haute brillance.

Diaceram 2-step

Zweistufiges Poliersystem für alle gängigen Keramiken. Diamantierte Polierer zum Polieren, Finieren und Hochglanzpolieren.

Diaceram 2-step

Sistema de pulido de dos fases para todas las cerámicas habituales. Pulidores diamantados para el pulido, el acabado y el pulido de alto brillo.

Diaceram 2-step

Sistema di lucidatura a due fasi per tutte le ceramiche in commercio. Gommini diamantati per lucidatura, finitura e brillantatura.

Diaceram 2-step

S: RA

speed 6.000 rpm

L	7	9	6	7	9	6
D \varnothing 1/10 mm	033	065	100	033	065	100
Order-No	100RA	101RA	102RA	110RA	111RA	112RA
ISO shape	243	030	304	243	030	304
P	70	71	72	70	71	72
VE 	6	6	6	6	6	6
Step	1	1	1	2	2	2



Diaceram 2-step

S: FG

speed 6.000 rpm

L	7	9	7	9
D \varnothing 1/10 mm	033	060	033	060
Order-No	100FG	101FG	110FG	111FG
ISO shape	243	030	243	030
P	70	70	72	72
VE 	6	6	6	6
Step	1	1	2	2



Diaceram 3-step

Polishing system for all ceramics including zirconia in 3 steps. Diamond-impregnated polishers for abrasion (step 1), polishing and smoothing of surfaces (step 2) and high shine (step 3).

Diaceram 3-step

Système de polissage en trois étapes pour toutes les céramiques courantes, y compris le zircon. Polissoirs diamantés pour abrasion (étape 1), polissage et lissage superficiel (étape 2) et la haute brillance (étape 3).

Diaceram 3-step			
S: FG			
speed 6.000 rpm			
L	7	7	7
D \varnothing 1/10 mm	033	033	033
Order-No	150FG	160FG	170FG
ISO shape	243	243	243
P	70	70	70
VE 	6	6	6
Step	1	2	3

Diaceram 3-step

Dreistufiges Poliersystem für alle gängigen Keramiken einschließlich Zirkon. Diamantierte Polierer für Materialabtrag (Stufe 1), Polieren und Oberflächenglättung (Stufe 2) und Hochglanzpolitur (Stufe 3).

Diaceram 3-step

Sistema de pulido de tres fases para todas las cerámicas de uso habitual, incluido el zirconio. Pulidores diamantados para la remoción del material (fase 1), el pulido y el alisado de las superficies (fase 2) y el pulido de alto brillo (fase 3).

Diaceram 3-step

Sistema di lucidatura a tre fasi per tutte le ceramiche comuni, inclusa la zirconia. Strumenti diamantati per l'asportazione di materiale (livello 1), la lucidatura e la rifinitura superficiale (livello 2) e la finitura ultra lucida (livello 3).

Diaceram 3-step											
S: RA											
speed 6.000 rpm											
L	10,5	8,3	6	10,5	8,3	6	10,5	8,3	6		
D \varnothing 1/10 mm	045	060	100	045	060	100	045	060	100		
Order-No	150RA	151RA	152RA	160RA	161RA	162RA	170RA	171RA	172RA		
ISO shape	243	030	304	243	030	304	243	030	304		
P	70	72	72	70	72	72	70	72	72		
VE 	6	6	6	6	6	6	6	6	6		
Step	1	1	1	2	2	2	3	3	3		

Adjustment kit for zirconia, IPS e.max® and porcelain (RA)

P: 370

S: RA



L	10,5	8,3	6,0	10,5	8,3	6,0	10,5	8,3	6,0	3,0
S	RA	RA	RA	RA	RA	RA	RA	RA	RA	RA
\varnothing	045	060	100	045	060	100	045	060	100	090
Step	1	1	1	2	2	2	3	3	3	-
P	70	72	72	70	72	72	70	72	72	76
Order-No	150 RA	151 RA	152 RA	160 RA	161 RA	162 RA	170 RA	171 RA	172 RA	260 RA

IPS e.max® ist eine eingetragene Marke der Firma Ivoclar Vivadent.
IPS e.max® is registered trademark of Ivoclar Vivadent.

Diacomp

Polishing system in 2 steps for composites. Polyurethane polishers with silicone carbide and diamonds.

Diacomp

Système de polissage en deux étapes pour tous les composites courants. Polissoirs résistants composés de polyuréthane, carbure de silicium et diamant.

Diacomp

Zweistufiges Poliersystem für Komposite. Polierer aus hochbeständigem Polyurethan mit Siliziumkarbid und Diamant.

Diacomp

Sistema de pulido de dos fases para todas las resinas compuestas habituales. Pulidores de poliuretano altamente resistentes con carburo de silicio y diamante.

Diacomp

Sistema di lucidatura a due fasi per tutti i compositi comuni. Strumenti di lucidatura in poliuretano altamente resistente con carburo di silicio e diamante.

Diacomp

S: RA

speed 6.000 rpm



L	7	9	6	10,5	7	9	6	10,5
D \varnothing 1/10 mm	033	065	100	050	033	065	100	050
Order-No	180RA	181RA	182RA	183RA	190RA	191RA	192RA	193RA
ISO shape	243	030	304	243	243	030	304	243
P	73	73	73	73	73	73	73	73
VE 	6	6	6	6	6	6	6	6
Step	1	1	1	1	2	2	2	2

Diacomp

S: FG

speed 6.000 rpm



L	7	7
D \varnothing 1/10 mm	033	033
Order-No	180FG	190FG
ISO shape	243	243
P	73	73
VE 	6	6
Step	1	2

Diatemp

Silicone polishing system in 2 steps for provisionals.

Diatemp

Sistema de pulidores de silicona de dos fases para provisionales.

Diatemp

Système de polissage silicone en deux étapes pour prothèses provisoires.

Diatemp

Sistema di lucidatura in silicone a due fasi per provvisori.

Diatemp

Zweistufiges Silikonpoliersystem für Provisorien.

Diatemp

S: HP

speed 8.000 rpm



L	-	16,0	9,5	-	16,0	9,5
D \varnothing 1/10 mm	120	055	070	120	055	070
Order-No	231HP	232HP	233HP	241HP	242HP	243HP
ISO shape	303	243	030	303	243	030
P	74	74	74	74	74	74
VE 	6	6	6	6	6	6
Step	1	1	1	2	2	2

Diabrush ceram

Polishing brushes containing abrasive grains for ceramics and composites. You will rapidly achieve excellent polishing results. Note: intermittent pressure and low speed.

Diabrush ceram

Cepillos con grano abrasivo para pulir cerámica y resinas compuestas. Diabrush ceram permite obtener excelentes resultados de pulido en muy poco tiempo. Es importante ejercer siempre una presión intermitente y utilizar velocidades bajas.

Diabrush ceram

Brosses à polir avec grain abrasif pour céramiques et composites. Diabrush ceram permet d'obtenir rapidement d'excellents résultats. Attention : pression intermittente et faible vitesse.

Diabrush ceram

Spazzolini di lucidatura con grano abrasivo per ceramica e composito. Diabrush ceram consente di ottenere ottimi risultati di lucidatura in brevissimo tempo. Applicare una pressione intermittente e rispettare il basso numero di giri.

Diabrush ceram

Polierbürsten mit abrasivem Korn für Keramik und Komposite. Diabrush ceram ermöglicht exzellente Polierergebnisse in kürzester Zeit. Mit intermittierendem Druck und bei niedrigen Drehzahlen verwenden.

Diabrush ceram

S: RA

speed 1.000-3.000 rpm



L	5	8
D \varnothing 1/10 mm	070	045
Order-No	250RA	251RA
ISO shape	541	542
P	75	75
VE 	2	2



Diaswiss Felt

Diamond-impregnated felt for ultimate high-shine. Not for sterilization. Single use only.

Diaswiss Felt

Filtros diamantados para un excelente pulido de alto brillo. No esterilizables, desechables.

Diaswiss Felt

Feutres diamantés pour brillantage ultime. Non stérilisables. Article à usage unique.

Diaswiss Felt

Feltri diamantati per una finitura ultra lucida finale. Non sterilizzabili, solo monouso.

Diaswiss Felt

Diamantierte Filze für den ultimativen Hochglanz. Nicht sterilisierbar. Nicht wiederverwendbar.



Diaswiss Felt

S: RA

speed 1.000-3.000 rpm

L	3
D ø 1/10 mm	090
Order-No	260RA
ISO shape	372
P	76
VE 	12



Diaprophy

The new prophylaxis polishing system. Easy handling and excellent polishing results without damage to the tooth surface.

Diaprophy

El nuevo sistema de pulido de Diaswiss para profilaxis. Manejo sencillo y resultados de pulido óptimos sin dañar la superficie dentaria.

Diaprophy

Le nouveau système de polissage pour la prophylaxie. Simple à manier, ce système donne d'excellents résultats sans endommager la superficie de la dent.

Diaprophy

Nuovo sistema di lucidatura Diaswiss per la profilassi. Utilizzo estremamente facile e ottimi risultati di lucidatura senza danneggiare la superficie dentale.

Diaprophy

Das neue Diaswiss Poliersystem für die Prophylaxe. Einfache Handhabung und beste Polierergergebnisse ohne Schädigung der Zahnoberfläche.



Diaprophy

S: UM

speed 6.000 rpm

L	13,5	8,5
D ø 1/10 mm	060	085
Order-No	270UM	271UM
ISO shape	243	030
P	77	77
VE 	20	20
	incl. 1 mandrel	incl. 1 mandrel

Note: see dental lab section for polishers for acrylics

N.B. : pour les polissoirs pour résines prothétiques, voir la section laboratoire

Hinweis: siehe Laborteil betreffend Polierer für Prothesenkunststoff

Nota: consulte los pulidores para prótesis de acrílico en la parte laboratorio dental.

Nota: Vedere la parte laboratorio per quanto riguarda gli strumenti di lucidatura per protesi in resina.

Surgical burs

Diaswiss offers a range of surgical instruments made of different materials including stainless steel, diamond, carbide and zirconia. This includes a selection of standard bone cutters as well as innovative instruments such as tissue trimmers for soft tissue.

Order-No

Please use the number indicated as "Order-No" plus the desired diameter.

Packaging

Diaswiss surgical burs are packed individually.

Recommended speed:

- Bone cutters (RA): max 30.000 rpm
- FG shank: max 100.000 rpm
- Surgicut: max 300.000 rpm

Fraises chirurgicales

Diaswiss propose un grand nombre d'instruments de chirurgie dans différents matériaux, comme l'acier inoxydable, le diamant, le carbure de tungstène et le zircon. Nous proposons également des fraises pour les découpes d'os ainsi que des instruments innovants pour le traitement des tissus mous.

Référence

La référence est indiquée pour chaque article en anglais («Order-No.»). Veuillez s'il vous plaît toujours indiquer à la commande cette référence ainsi que le diamètre.

Emballage

Les fraises chirurgicales Diaswiss sont emballées individuellement.

Vitesses recommandées :

- Fraises à os (CA): maximum 30'000 tpm
- Tige FG: maximum 100'000 tpm
- Surgicut: maximum 300'000 tpm

Chirurgische Instrumente

Diaswiss bietet ein Sortiment an chirurgischen Instrumenten aus rostbeständigem Stahl, Diamant, Hartmetall sowie Zirkon an. Hierzu gehört auch eine Auswahl an gängigen Knochenfräsern sowie innovative Instrumente zur Bearbeitung von Weichgewebe.

Bestellnummer

Die Bestellnummer ist als „Order-No.“ bei jedem Artikel angegeben, bitte verwenden Sie stets diese Bestellnummern mit Angabe des gewünschten Durchmessers.

Verpackung

Chirurgische Instrumente werden einzeln verpackt.

Drehzahlempfehlung:

- Knochenfräser (WST): max 30.000 UpM
- FG Schaft: max 100.000 UpM
- Surgicut: max 300.000 UpM

Instrumentos quirúrgicos

Diaswiss ofrece una gama completa de instrumentos quirúrgicos en acero inoxidable, diamante, tungsteno y zirconio. El programa también incluye una amplia selección de fresas para hueso además de instrumentos innovadores para el tratamiento de los tejidos blandos.

Número de pedido

El número de pedido aparece indicado en todos los artículos como "Order-No.". Por favor, utilice siempre este número indicando el diámetro deseado.

Envase

Los instrumentos quirúrgicos Diaswiss se suministran en envases individuales.

Velocidad:

- Fresas para hueso (CA): máx. 30.000 rpm
- Vástago FG: máx. 100.000 rpm
- Surgicut: máx. 300.000 rpm

Strumenti chirurgici

Diaswiss offre un assortimento di strumenti chirurgici in diversi materiali, quali acciaio inossidabile, diamante, carburo di tungsteno e zirconia. Fa parte di questo assortimento un'ampia scelta di frese ossee e strumenti innovativi per il trattamento dei tessuti molli.

Numero d'ordine

Il numero d'ordine è indicato con "Order-No." per ogni articolo. Per ordinazioni si prega di utilizzare sempre questo numero e di indicare il diametro desiderato.

Confezione

Gli strumenti chirurgici Diaswiss sono confezionati singolarmente.

Velocità:

- Frese ossee (CA): max. 30.000 giri/min
- Gambo FG: max. 100.000 giri/min
- Surgicut: max. 300.000 giri/min

C 168



Suggested application
Conseils d'utilisation
Anwendungsvorschlag
Propuesta de aplicación
Consigli d'uso

Shape
Forme
Form
Forma
Forma

L

Head length
Longueur de la tête
Kopflänge
Longitud de la cabeza
Lunghezza della testa

S

Shank
(e.g. RA for right angle, FG)

Tige
(p. ex. RA pour contre-angle, FG)

Schaft
(z.B. RA für Winkelstück, FG)

Vástago
(p. ej. RA para contraángulo, FG)

Gambo
(ad es. RA per contrangolo, FG)



C 168
ISO 407
= 6

Order-No

Order number (please add the desired diameter)
Référence (veuillez s'il vous plaît ajouter le diamètre demandé)
Bestellnummer (bitte gewünschten Durchmesser hinzufügen)
Número de pedido (indique por favor el diámetro deseado)
Numero d'ordine (indicare anche il diametro)

Ø 1/10 mm

Head diameter
Diamètre de la tête
Kopfdurchmesser
Diámetro de la cabeza
Diametro testa

L	10,0
S	Order-No
FG L	315 C 168 ... 014
P	38

P

Price category
Catégorie de prix
Preisgruppe
Grupo de precios
Gruppo prezzo

Carbide

C 141

Allport
ISO 001

 = 6 or 1



L		-				
S	Order-No	ø 1/10 mm				
RA L	205 C 141 ...	027	031	035	040	050
HP	104 C 141 ...	027	031			050
P		80	80	80	80	80



C 141X

Allport
ISO 001

 = 6 or 1



L		-				
S	Order-No	ø 1/10 mm				
RA L	205 C 141X ...	027	031	035	040	050
P		80	80	80	80	80

C 151

ISO 210

 = 6



L		11,0
S	Order-No	ø 1/10 mm
FG XL	316 C 151 ...	015
RA L	205 C 151 ...	015
P		81

C 152

ISO 199

 = 6



L		9,0
S	Order-No	ø 1/10 mm
FG XL	316 C 152 ...	015
RA	204 C 152 ...	015
P		81

C 161

Bone cutters
Lindemann
ISO 408

 = 6



L		9,0
S	Order-No	ø 1/10 mm
FG XL	316 C 161 ...	016
RA L	205 C 161 ...	016
HP	104 C 161 ...	016
P		81

C 162

Bone cutters
Lindemann
ISO 408

 = 6



L		9,0
S	Order-No	ø 1/10 mm
FG XL	316 C 162 ...	016
RA L	205 C 162 ...	016
HP	104 C 162 ...	016
P		81

C 168

ISO 407

 = 6



L		10,0
S	Order-No	ø 1/10 mm
FG XL	316 C 168 ...	014
P		82



C 184

ISO 192

 = 6

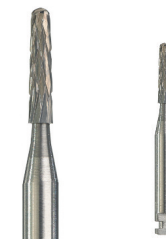

L		8,0
S	Order-No	ø 1/10 mm
RA	204 C 184 ...	016
P		81

C 687

ISO 687

 = 6



L		11,0
S	Order-No	ø 1/10 mm
RA L	205 C 687 ...	016
P		81



C 687X

ISO 687

 = 6



L		11,0
S	Order-No	ø 1/10 mm
RA L	205 C 687X ...	023
P		82

CB 255A

ISO 534

 = 6



L		6
S	Order-No	ø 1/10 mm
FG L	315 CB 255A ...	012
FG XL	316 CB 255A ...	012
P		81

Carbide diamond coated



C 389

ISO 389



L		8,5	8,5	8,5
S	Order-No	ø 1/10 mm		
FG	314 C 389 ...	012	014	018
FG XL	316 C 389 ...	012	014	018
P		84	84	84

**Stainless steel
diamond coated**

RF 411

ISO 411



L		11	11	11
S	Order-No	ø 1/10 mm		
FG L	315 RF 411 ...	016	018	021
P		85	85	85
L		12		
RA L	205 RF 411 ...	018		
P		85		

Stainless steel

RF 161

Bone cutters
Lindemann
ISO 408



L		10
S	Order-No	∅ 1/10 mm
FG L	315 RF 161 ...	016
P		86

RF 162

Bone cutters
Lindemann
ISO 408



L		10
S	Order-No	∅ 1/10 mm
FG L	315 RF 162 ...	016
P		86
RA L	205 RF 162 ...	016
P		86

RF 165

Bone cutter
Lindemann
ISO 407



L		7
S	Order-No	∅ 1/10 mm
RA L	205 RF 165 ...	022
P		86

RF 166

Bone cutter
Lindemann
ISO 407



L		8
S	Order-No	∅ 1/10 mm
RA L	205 RF 166 ...	021
P		86

RF 167

Bone cutter
Lindemann
ISO 407



L		12
S	Order-No	∅ 1/10 mm
RA L	205 RF 167 ...	022
P		87

RF 407

Bone cutter
Lindemann
ISO 407



L		9
S	Order-No	∅ 1/10 mm
FG L	315 RF 407 ...	014
P		87

RF 410

Bone cutter
Lindemann
ISO 410



L		12
S	Order-No	∅ 1/10 mm
FG L	315 RF 410 ...	016
P		86

Z 164

ISO 164



	L	5
S	Order-No	∅ 1/10 mm
FG	314 Z 164 ...	015
	P	88

Surgicut

- Precision tissue trimmers
- Reduces bleeding as heated tip causes blood coagulation
- Made of yttrium-stabilized zirconia
- No water cooling
- Apply at 90° angle with light pressure
- Max. speed: 300.000 rpm

Z 164L

ISO 164



	L	8
S	Order-No	∅ 1/10 mm
FG	314 Z 164L ...	015
	P	88

Surgicut

- Instruments de précision pour traitement de tissus mous
- Réduit les saignements grâce à l'échauffement de la pointe qui engendre la coagulation sanguine
- En zircone stabilisé par yttrium
- Utiliser sans irrigation à un angle de 90° avec légère pression
- Vitesse maximale recommandée: 300'000 tpm

Surgicut

- Präzisions-Gewebeschneider zur Behandlung von Weichgewebe
- Reduziert Blutungen aufgrund der Erwärmung der Spitze, welche zur Blutkoagulation führt
- Yttrium-stabilisiertes Zirkon
- Ohne Wasserkühlung senkrecht zur Schnittrichtung halten und mit leichtem Druck führen
- Drehzahl: max. 300.000 UpM

Surgicut

- Instrumentos de precisión para cortar tejido blando
- Disminuye las hemorragias gracias al calentamiento de la punta y la coagulación (sangrado mínimo)
- Fabricado de zirconio estabilizado por itrio
- Sin refrigeración por agua
- Aplicar perpendicularmente a la dirección del corte ejerciendo una ligera presión.
- Velocidad máxima: 300.000 rpm

Surgicut

- Mucotomi di precisione per il trattamento dei tessuti molli
- Impedisce quasi completamente la formazione di sanguinamenti grazie al riscaldamento della punta e alla conseguente coagulazione
- In zirconio stabilizzato di ittrio
- Senz 'acqua di raffreddamento
- Tenere il surgicut ad angolo retto rispetto alla direzione di taglio ed applicare una leggera pressione
- Velocità massima: 300'000 giri/min

Endodontic instruments

The Diaswiss range of endodontic instruments consists of Hedstroem files, K-files, reamers, paste fillers and other instruments in all standard diameters and lengths. The Diaswiss instruments are made of stainless steel and packed as 12, 6 or 4 pcs.

The product **DIAtaper** is used with rotary endodontic contra-angles in a crown-down technique.

Recommended speed of use: between 250 and 350 RPM

Recommended maximum torque for use:

DSX and DS1:	3 – 4 N.cm
DS2:	1 – 1.5 N.cm
DF1:	1.5 – 2 N.cm
DF2 and DF3:	2 – 3 N.cm

Order-No

The order number is indicated for each article, please use these order numbers plus the desired diameter.

Instruments endodontiques

La gamme d'instruments canalaires de Diaswiss comprend des râcleurs, des limes K, des broches, des bourre-pâtes ainsi que d'autres instruments endodontiques disponibles dans les diamètres et longueurs les plus courants. Les instruments Diaswiss sont en acier inoxydable. Ils sont conditionnés par 12, 6 ou 4.

Le produit **DIAtaper** s'utilise avec des contre-angles à rotation continue.

Technique de Crown-down

Vitesse d'utilisation recommandée : 250 à 350 tr/min

Couple d'utilisation maximum recommandé :

DSX et DS1 :	3-4 N.cm
DS2 :	1-1.5 N.cm
DF1 :	1.5-2 N.cm
DF2 et DF3 :	2-3 N.cm

Référence

La référence est indiquée pour chaque article en anglais («Order-No.»). Veuillez s'il vous plaît toujours indiquer à la commande cette référence ainsi que le diamètre.

Endodontische Instrumente

Das Sortiment an Diaswiss Wurzelkanalinstrumenten umfasst Hedström-Feilen, K-Feilen, Bohrer, Wurzelfüller sowie weitere endodontische Instrumente in allen gängigen Durchmesser und Längen. Die Diaswiss Instrumente werden aus rostfreiem Stahl gefertigt und sind zu 12, 6 bzw. 4 Stück verpackt.

DIAtaper wird im Winkelstück mittels crown-down Technik angewandt.

Empfohlene Geschwindigkeit: zwischen 250 und 350 Upm

Empfohlenes maximales Drehmoment:

DSX und DS1:	3 – 4 N.cm
DS2:	1 – 1.5 N.cm
DF1:	1.5 – 2 N.cm
DF2 und DF3:	2 – 3 N.cm

Bestellnummer

Die Bestellnummer ist als „Order-No.“ bei jedem Artikel angegeben, bitte verwenden Sie stets diese Bestellnummern mit Angabe des gewünschten Durchmessers.

Instrumentos de endodoncia

La gama de instrumentos para el canal radicular de Diaswiss incluye limas tipo Hedström, limas K, fresas, obturadores radiculares y otros instrumentos en los diámetros y las longitudes más habituales. Los instrumentos Diaswiss están fabricados en acero inoxidable y están disponibles en envases de 12, 6 o 4 unidades.

Los **DIAtaper** se utilizan en el contra-ángulo mediante la técnica crown-down.

Velocidad recomendada: entre 250 y 350 rpm

Momento de torsión máximo recomendado:

DSX y DS1 :	3-4 N.cm
DS2 :	1-1.5 N.cm
DF1 :	1.5-2 N.cm
DF2 y DF3 :	2-3 N.cm

Número de pedido

El número de pedido aparece indicado en todos los artículos como "Order-No.". Por favor, utilice siempre este número indicando el diámetro deseado.

Strumenti canalari ENDO

L'assortimento di strumenti canalari Diaswiss comprende lime di Hedström, lime K, frese, spingipasta e d'altri strumenti in tutti i diametri e lunghezze comuni. Gli strumenti Diaswiss sono realizzati in acciaio inossidabile e imballati in confezioni da 12, 6 o 4 pezzi.

Il prodotto **DIAtaper** viene utilizzato con contrangoli a rotazione continua. Tecnica Crown-down

Velocità di utilizzo consigliata: da 250 a 350 giri/min

Coppia massima d'uso consigliata:

DSX e DS1:	3-4 [N.cm]
DS2:	1-1,5 [N.cm]
DF1:	1,5-2 [N.cm]
DF2 e DF3:	2-3 [N.cm]

Numero d'ordine

Il numero d'ordine è indicato con "Order-No." per ogni articolo. Per ordini si prega di utilizzare sempre questo numero e di indicare il diametro desiderato.

Hedstroem Files

Product type
Type de produit
Produkttyp
Tipo de producto
Tipo di prodotto

ISO
ISO diameter in 1/10
Diamètre ISO en 1/10
ISO Durchmesser in 1/10
Diámetro ISO en 1/10
Diametro ISO in 1/10

Order-No
Order number (please add the desired diameter)
Réf rence (veuillez s'il vous pla t ajouter le diam tre demand )
Bestellnummer (bitte gew nschten Durchmesser hinzuf gen)
N mero de pedido (indique por favor el di metro deseado)
Numero d'ordine (indicare anche il diametro)

L / Ref
Length
Longueur
L nge
Longitud
Lunghezza

Hedstroem Files

ISO		Ø 1/10 mm			
L / Ref	Order-No	25	30	35	40
21 / 321	321 021 ...	025	030	035	040
25 / 325	325 025 ...	025	030	035	040
31 / 331	331 031 ...	025	030	035	040
P		61	61	61	61
A [P]		15 - 40 [61]			

A [P]
Assortment [price category]
Conditionnement assorti [groupe de prix]
Sortierte Verpackung [Preisgruppe]
Envase surtido [Grupo de precios]
Confezione assortita [gruppo prezzo]

P
Price category
Cat gorie de prix
Preisgruppe
Grupo de precios
Gruppo prezzo



DIA taper



ISO	Order-No	DSX	DS1	DS2	DF1	DF2	DF3
		019	017	020	20	25	30
L / Ref	Order-No	ø 1/10 mm					
19 / 725	725 019 ...	019					
21 / 725	725 021 ...		017	020			
21 / 726	726 021 ...				020	025	030
25 / 725	725 025 ...		017	020			
25 / 726	726 025 ...				020	025	030
31 / 725	725 031 ...		017	020			
31 / 726	726 031 ...				020	025	030
P		69	69	69	69	69	69
A 21mm [P]	727021Set	each 21 mm [XX]					
A 25mm [P]	727025Set	each 25 mm [XX]					
A 31mm [P]	727031Set	each 23 mm [XX]					

Hedstrom Files

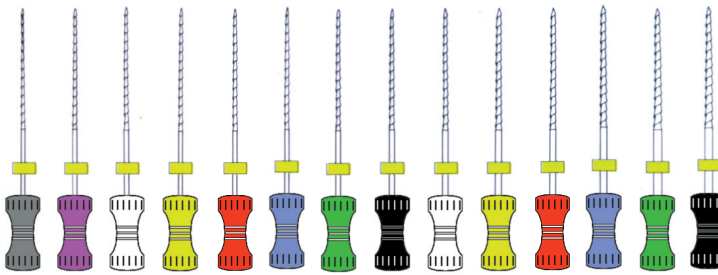

ISO	Order-No	08	10	15	20	25	30	35	40	45	50	55	60	70	80
L / Ref	Order-No	ø 1/10 mm													
21 / 321	321 021 ...	008	010	015	020	025	030	035	040	045	050	055	060	070	080
25 / 325	325 025 ...	008	010	015	020	025	030	035	040	045	050	055	060	070	080
29 / 331	331 031 ...	008	010	015	020	025	030	035	040	045	050	055	060	070	080
P		61	61	61	61	61	61	61	61	61	61	62	62	62	62
A [P]		15 - 40 [61]						45 - 80 [62]							

K - Files

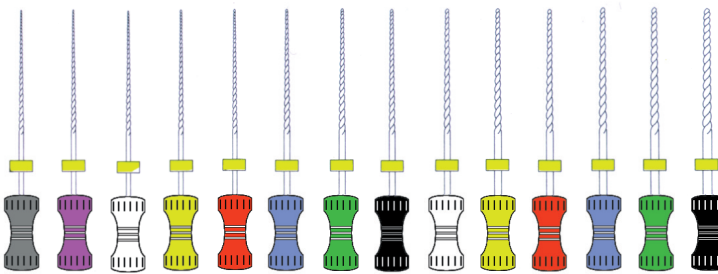

ISO	Order-No	08	10	15	20	25	30	35	40	45	50	55	60	70	80
L / Ref	Order-No	ø 1/10 mm													
21 / 121	121 021 ...	008	010	015	020	025	030	035	040	045	050	055	060	070	080
25 / 125	125 025 ...	008	010	015	020	025	030	035	040	045	050	055	060	070	080
29 / 131	131 031 ...	008	010	015	020	025	030	035	040	045	050	055	060	070	080
P		61	61	61	61	61	61	61	61	61	61	62	62	62	62
A [P]		15 - 40 [61]						45 - 80 [62]							

Reamers

= 6

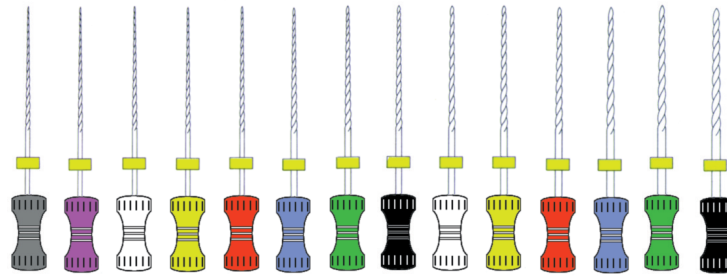

ISO	08	10	15	20	25	30	35	40	45	50	55	60	70	80	
L / Ref	Order-No														
	ø 1/10 mm														
21 / 221	221 021 ...	008	010	015	020	025	030	035	040	045	050	055	060	070	080
25 / 225	225 025 ...	008	010	015	020	025	030	035	040	045	050	055	060	070	080
29 / 231	231 031 ...	008	010	015	020	025	030	035	040	045	050	055	060	070	080
P	63	63	63	63	63	63	63	63	63	63	64	64	64	64	
A [P]	15 - 40 [63]						45 - 80 [64]								

Barbed broaches

= 12

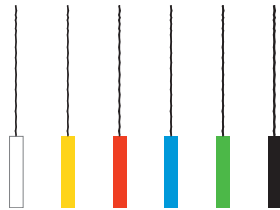

ISO	25	30	35	40	50	60	
L / Ref	Order-No						
	ø 1/10 mm						
31 / 425	425 031 ...	025	030	035	040	050	060
P	67	67	67	67	67	67	
A [P]	25 - 60 [67]						

Spring paste fillers

= 4

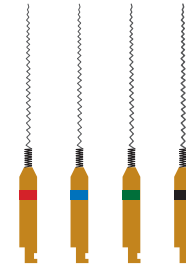

ISO	25	30	35	40	
L / Ref	Order-No				
	ø 1/10 mm				
25 / 825	825 025 ...	025	030	035	040
P	68	68	68	68	
A [P]	25 - 40 [68]				

Gates

= 6

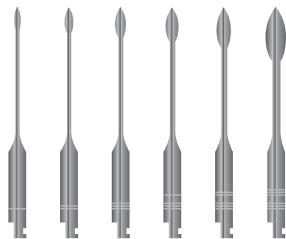

ISO	50	70	90	110	130	150	
L / Ref	Order-No						
	ø 1/10 mm						
25 / 625	625 025 ...	050	070	090	110	130	150
P	66	66	66	66	66	66	
A [P]	50 - 150 [66]						

Peeso

= 6

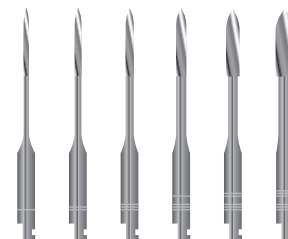

ISO	70	90	110	130	150	170	
L / Ref	Order-No						
	ø 1/10 mm						
32 / 525	525 032 ...	070	090	110	130	150	170
P	66	66	66	66	66	66	
A [P]	70 - 170 [66]						

Bur blocks

sterilizable up to 135°C

24 pieces FG, HP, RA

Order-no. Bur block FG 24
Bur block HP 24
Bur block RA 24

P: 90

48 pieces FG or HP

Order-no. Bur block FG 48
Bur block HP 48

P: 91

72 pieces FG, HP, RA

Order-no. Bur block FG 72
Bur block HP 72
Bur block RA 72

P: 92

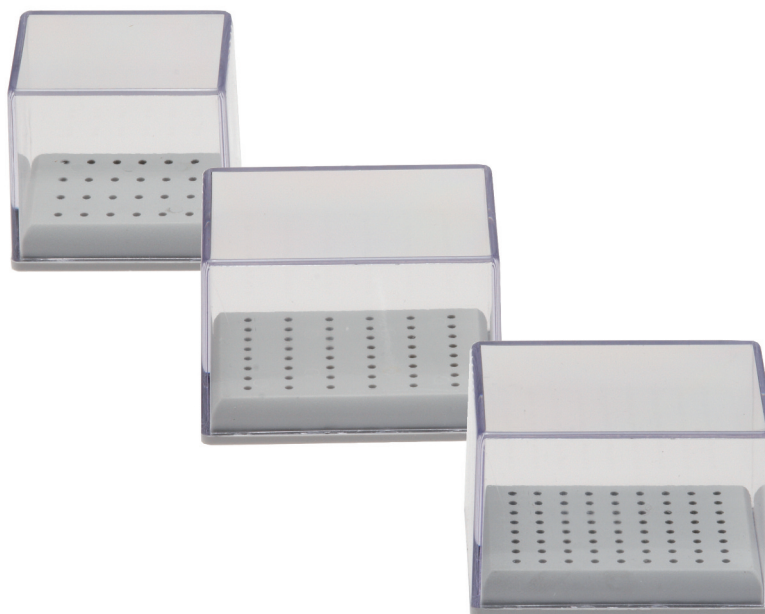

Porte-fraises

stérilisable à une température maxi de 135 °C

Bohrerstände

sterilisierbar bis 135°C

Fresero

esterilizable hasta 135 °C

Portafrese

sterilizzabile fino a 135°C

24 pièces FG, PM, CA

Référence Bur block FG 24
Bur block HP 24
Bur block RA 24

P: 90

24 Stück FG, HST, WST

Best.-Nr. Bur block FG 24
Bur block HP 24
Bur block RA 24

P: 90

24 unidades FG, PM, CA

Num. pedido Bur block FG 24
Bur block HP 24
Bur block RA 24

P: 90

24 pezzi FG, H.P., CA

Num. d'ordine Bur block FG 24
Bur block HP 24
Bur block RA 24

P: 90

48 pièces FG ou PM

Référence Bur block FG 48
Bur block HP 48

P: 91

48 Stück FG oder HST

Best.-Nr. Bur block FG 48
Bur block HP 48

P: 91

48 unidades FG o PM

Num. pedido Bur block FG 48
Bur block HP 48

P: 91

48 pezzi FG o H.P.

Num. d'ordine Bur block FG 48
Bur block HP 48

P: 91

72 pièces FG, PM, CA

Référence Bur block FG 72
Bur block HP 72
Bur block RA 72

P: 92

72 Stück FG, HST, WST

Best.-Nr. Bur block FG 72
Bur block HP 72
Bur block RA 72

P: 92

72 unidades FG, PM, CA

Num. pedido Bur block FG 72
Bur block HP 72
Bur block RA 72

P: 92

72 pezzi FG, H.P., CA

Num. d'ordine Bur block FG 72
Bur block HP 72
Bur block RA 72

P: 92

Reducers

No medical device, not for intraoral use.

Réducteurs

Les réducteurs et mandrins ne sont pas des dispositifs médicaux et ne sont pas destinés à l'usage intraoral.

Reduzierstücke

Kein Medizinprodukt, nicht für intraoralen Einsatz.

Reductores

No es producto sanitario. No indicado para uso intraoral.

Riduttori

Non é un dispositivo medico, non per uso intraorale.

L	190	240	340
	FG - HP	FG - RA	FG - HP
Order-No	Reducer1	Reducer2	Reducer3
P	93	94	95

Diacleen

Concentrate for the disinfection and cleaning of dental and surgical instruments.

Outstanding performance. Safe. Economical.

Properties:

Excellent disinfecting characteristics, suitable for all dental and surgical instruments. Highly effective against bacteria (incl. MRSA) and yeast (EN 13727/13624). Tested in accordance with the directives of the DGHM (Deutsche Gesellschaft für Hygiene und Mikrobiologie) under high organic load in 15 minutes in a 3% solution and 60 minutes in a 1% solution. Guarantees active protection against tuberculosis (M.terrae) in 30 minutes in a 3% solution (EN 14348). Fungicide (T.interdigitale) in 30 minutes in a 3% solution (EN 13624). Inactivates HBV / HCV / HIV / HPV / BVDV / Vaccinia / SV40 / Noroviruses in 15 minutes in a 3% solution (EN 14476). Contains no aldehydes and phenols. Non-corrosive. Suitable for use in an ultrasound device in 5 minutes in a 4% solution. Biodegradable.

Precautions:

Keep away from heat, hot surfaces, sparks, open flames and other ignition sources. Keep out of reach of children, store locked up in a cool, well-ventilated place. Protect from sunlight.

Content	Order no	P
1000 ml	90950	103
5000 ml	90960	104

Diacleen

Concentré pour la désinfection et le nettoyage des instruments dentaires et chirurgicaux.

Efficace. Fiable. Economique.

Propriétés :

Diacleen est bactéricide (y compris MRSA) et levuricide (EN 13727/13624). Testé selon les directives de la DGHM/VAH (Deutsche Gesellschaft für Hygiene und Mikrobiologie) du 02.04.2015 avec des valeurs courtes en 15 min/3% et 60 min/1% même sous forte charge organique. Protection active contre M. terrae en 30 min/3% (EN 14348), fongicide (T. interdigitale) en 30 min/3% (EN13624). Rend inactif les virus VHB / VHC /VIH/ VHP / BVDV / Vaccinée / SV40 / Noro en 15 min/3% (EN14476). Libre de phénols et d'aldéhydes. Excellentes propriétés anticorrosives. Usage dans le bain à ultrason (laisser tremper les instruments 5 min/4%). Biodégradable.

Précautions :

Ne pas exposer à la chaleur, les surfaces chaudes, les étincelles, les flammes nues et toute autre source d'inflammation. Tenir hors de portée des enfants. Garder sous clef et tenir au frais. Stocker dans un endroit bien ventilé. Protéger du rayonnement solaire.

Contenu	Référence	P
1000 ml	90950	103
5000 ml	90960	104

Diacleen

Konzentrat zur Desinfektion und Reinigung dentaler und chirurgischer Instrumente.

Leistungsstark. Sicher. Wirtschaftlich.

Eigenschaften:

Diacleen ist für dentale und chirurgische Instrumente geeignet. Ausgezeichnete bakterizide Wirksamkeit (einschließlich MRSA), levurozid (EN 13727/13624). Diacleen wurde nach den Richtlinien der DGHM/VAH (Deutsche Gesellschaft für Hygiene und Mikrobiologie, Stand: 02.04.2015) mit Kurzzeitwerten von 3% in 15 Minuten und 1% in 60 Minuten unter hoher organischer Belastung getestet und gelistet. Wirkt tuberkulozid (M.terrae) in einer 3%igen Lösung in 30 Minuten (EN 14348). Wirkt fungizid (T.interdigitale) in einer 3%igen Lösung in 30 Minuten (EN 13624). Wirkt begrenzt viruzid. Inaktiviert behüllte Viren (HBV / HCV / HIV / HPV / BVDV / Vaccinia) sowie unbehüllte Viren (SV40 / Noro-Viren) in einer 3%igen Lösung 15 Minuten (EN 14476). Frei von Aldehyden und Phenolen. Ausgezeichnetes Korrosionsverhalten. Wirksam im Ultraschallbad in 5 Minuten in einer 4%igen Lösung. Nicht proteinfixierend. Die Gebrauchslösung ist biologisch abbaubar.

Wichtige Hinweise:

Von Hitze, heißen Oberflächen, Funken, offenen Flammen sowie anderen Zündquellen fernhalten. Darf nicht in die Hände von Kindern gelangen. Unter Verschluss und kühl aufbewahren. An einem gut belüfteten Ort lagern und vor Sonnenbestrahlung schützen.

Inhalt	Bestell-Nr.	P
1000 ml	90950	103
5000 ml	90960	104

Diacleen

Concentrado para la desinfección y limpieza de instrumentos odontotécnicos y quirúrgicos.

Alto rendimiento. Manejo seguro. Económico.

Propiedades:

Diacleen tiene un efecto bactericida (incluso MRSA), levurocida (EN 13727 / 13624) y fue listado y sometido a pruebas con valores de acción a corto plazo del 3 % a 15 minutos y 1 % en 60 minutos bajo alta carga orgánica según las directivas de la DGHM / VAH (Deutsche Gesellschaft für Hygiene und Mikrobiologie) en su variante con fecha 02.04.2015. Tiene efecto tuberculocida (M. Terrae) en una solución al 3 % en 30 minutos (EN 14348). Tiene efecto fungicida (T. interdigitale) en una solución al 3 % en 30 minutos (EN 13624). En el caso de virus inactivos con envoltura (VHB / VHC / VIH / VPH / VDVB / Vaccinia /) así también virus sin envoltura (SV40 / Noro) se logra el efecto en 15 minutos en una solución al 3 % (EN14476). Libre de aldehídos y fenoles. Tiene excelentes propiedades anticorrosivas. Efectivo en el baño ultrasónico en 5 minutos en una solución al 4 %. La solución de trabajo es biodegradable.

Precauciones:

Mantener alejado del calor, superficies calientes, chispas, llamas abiertas y otras fuentes de ignición. Mantener fuera del alcance de los niños. Guardar bajo llave. Conservar en un lugar fresco. Almacenar en un lugar bien ventilado. Proteger de la luz del sol.

Contenido	N.º de pedido	P
1000 ml	90950	103
5000 ml	90960	104

Diacleen

Concentrato per la disinfezione e la pulizia di strumenti odontoiatrici.
Efficace. Sicuro. Economico.

Proprietà:

Diacleen ha effetto battericida (incluso MRSA), levuricida (EN13727 / 13624) ed è stato testato ed elencato secondo le direttive della DGHM/VAH (Società tedesca di igiene e microbiologia, aggiornamento: 02.04.2015) con valori in tempi brevi del 3% in 15 minuti e dell'1% in 60 minuti sotto elevato carico organico. Ha effetto tubercolicida (M.terrae) in una soluzione al 3% in 30 minuti (EN 14348). Ha effetto fungicida (T. interdigitale) in una soluzione al 3% in 30 minuti (EN 13624). Ha limitata azione viricida. Inattiva i virus capsulati (HBV/HCV/HIV/HPV/BVDV/Vaccinia virus) e i virus non capsulati (SV40/norovirus) in una soluzione al 3% in 15 minuti (EN14476). Privo di aldeidi e fenoli. Eccellente resistenza alla corrosione. Efficace in bagno a ultrasuoni in soluzione al 4% in 5 minuti. Non fissa le proteine. La soluzione è biodegradabile. La confezione è omologata UN e riciclabile.

Precauzioni:

Tenere lontano da calore, superfici calde, scintille, fiamme libere e altre fonti di combustione. Tenere lontano dalla portata dei bambini. Conservare sottochiave. Conservare al fresco. Conservare in un luogo ben ventilato. Proteggere dai raggi solari.

Contenuto	Num. d'ordine	P
1000 ml	90950	103
5000 ml	90960	104



Explanation of pictograms | Explication des pictogrammes | Erläuterung der Piktogramme Explicación de los pictogramas | Spiegazione delle pittogramme



See instructions for use
Lire les conseils d'utilisation
Gebrauchsanweisung beachten
Prestar atención a los consejos de utilización
Osservare le istruzioni d'uso



Manufacturer
Producteur
Hersteller
Fabricante
Produttore



Single use only
Usage unique
Nur zum Einmalgebrauch
Desechable
Monouso



To be used until
A utiliser avant
Verwendbar bis
Fecha de vencimiento
Utilizzabile fino al



Date of manufacturing
Date de production
Herstellungsdatum
Fecha de fabricación
Data di fabbricazione



Order number
Référéce
Bestellnummer
Número de pedido
Numero d'ordine



Attention
Attention
Achtung
Atención
Attenzione



LOT number
Numéro de LOT
Chargenbezeichnung
Denominación del lote
Specificazione numero di lotto

Information regarding E-Labeling | Note sur l'étiquetage électronique Hinweis zum E-Labeling | Indicaciones sobre E-Labeling | Informazione sull' E-Labeling

Information regarding E-Labeling

This icon on our packaging indicates that instructions for use for the respective products are available on our website www.diaswiss.ch.
Instructions for use are available for reading, download and printing.
Instructions for use in paper form are available free upon request within 7 days.

Note sur l'étiquetage électronique

Avec ce symbole sur nos emballages, nous précisons que les instructions d'utilisation du produit correspondantes se trouvent sur notre site web www.diaswiss.ch.
Vous pouvez afficher, enregistrer et imprimer les instructions d'utilisation.
Un manuel d'instructions sur papier est disponible gratuitement sur demande dans les 7 jours.

Hinweis zum E-Labeling

Mit diesem Symbol auf unseren Verpackungen weisen wir darauf hin, dass sich die Gebrauchsanweisungen des entsprechenden Produkts auf unserer Internetseite www.diaswiss.ch befinden.
Sie können die Gebrauchsanweisungen einsehen, herunterladen und ausdrucken.
Eine kostenfreie Gebrauchsanweisung in Papierform ist innerhalb von 7 Tagen auf Anfrage erhältlich.

Indicaciones sobre E-Labeling

Con este simbolo colocado sobre nuestros empaques señalamos que las instrucciones de uso del producto correspondiente se encuentran en nuestra página de internet www.diaswiss.ch.
Usted puede ver, descargar e imprimir las instrucciones de uso.
Una instrucción de uso gratuita en formato papel está disponible dentro de 7 dias bajo petición.

Informazione sulle E-Labeling

La presenza di questo simbolo sulla confezione indica che le istruzioni d'uso del relativo prodotto si trovano sul nostro sito Internet www.diaswiss.ch.
Le istruzioni d'uso possono essere lette, salvate e stampate.
È inoltre possibile ricevere gratuitamente una copia cartacea delle istruzioni d'uso, che vi saranno recapitate entro 7 giorni. Per richiederle, utilizzate il modulo di contatto.



-> www.diaswiss.ch



Flammable liquid and vapour
Liquid et vapeurs inflammables
Flüssigkeit und Dampf entzündbar
Líquidos y vapores inflamables
Liquido e vapori infiammabili



Causes severe skin burns and eye damage
Provoque des brûlures de la peau et des lésions oculaires graves
Verursacht schwere Verätzungen der Haut und schwere Augenschäden
Provoca quemaduras graves en la piel y lesiones oculares graves
Provoca gravi ustioni cutanee e gravi lesioni oculari



Very toxic to aquatic life with long-lasting effects
Très toxique pour les organismes aquatiques, entraîne des effets néfastes à long terme
Sehr giftig für Wasserorganismen mit langfristiger Wirkung
Muy tóxico para los organismos acuáticos, con efectos nocivos duraderos
Molto tossico per gli organismi acquatici con effetti di lunga durata

Dentistry Cabinet dentaire Zahnarzt Clinica dental Studio	6 - 76
Diamond instruments Instruments diamantés Diamantwerkzeuge Instrumentos diamantados Strumenti diamantati	8 - 43
Carbide instruments Fraises en carbure de tungstène Hartmetallwerkzeuge Fresas en carburo de tungsteno Strumenti in carburo di tungsteno	44 - 55
Polishers Polissoirs Polierer Pulidores Gommini	56 - 62
Surgery Chirurgie Chirurgie Cirugia Strumenti chirurgici	63 - 68
Endodontic instruments Instruments endodontiques Endodontische Instrumente Instrumentos de endodoncia Strumenti canalari ENDO	69 - 72
Accessories Divers Sonstige Instrumente Accesorios Accessori	73
Disinfection and cleaning Désinfection et nettoyage Desinfektion und Reinigung Desinfección y limpieza Disinfezione e pulizia	74 - 75
Pictograms and E-Labeling Pictogrammes et étiquetage électronique Piktogramme und E-Labeling Pictogramas y E-Labeling Pittogramme ed E-Labeling	76
Dental lab Laboratoire Labor Laboratorio dental Laboratorio	78 - 162
Carbide instruments Fraises en carbure Hartmetallinstrumente Fresas en carburo de tungsteno Frese in carburo di tungsteno	78 - 99
Electroplated diamonds Instruments diamantés galvaniques Galvanische Diamanten Instrumentos diamantados galvánicos Strumenti diamantati galvanizzati	100 - 109
Sintered diamonds Instruments diamantés dans la masse Sinterdiamanten Instrumentos de diamante macizo Strumenti diamantati sinterizzati	110 - 117
Discs Disques Scheiben Discos Dischi	118 - 129
Zirconia tools Outils pour le zircon Zirkonwerkzeuge Instrumentos para zirconio Strumenti per zirconia	130 - 138
Polishers Polissoirs Polierer Pulidores Gommini	139 - 147
Tool Kits Sets de travail Bearbeitungssets Sets de elaboración Set di rifinitura	148 - 151
Consumables Consommables Verbrauchsartikel Consumibles Articoli di consumo	152 - 160
Accessories Divers Sonstige Instrumente Accesorios Accessori	161 - 162
Index Index Index Índice Indice	163 - 167

Carbide cutters

Diaswiss carbide instruments leave nothing to be desired in terms of durability, cutting efficiency, surface quality and the range available. In addition to plain and cross-cut designs, Diaswiss offers a range of innovative cuts for specific materials and applications. The manufacturing process of the carbide instruments is characterized by special features, which are of direct benefit to the user. This includes the complex carbide soldering, when the shaft is inserted into the carbide head during the soldering process resulting in significantly greater stability, less risk of breakage and better true running.

Order-No

The order number is indicated as "Order-No." for each article. Please use these order numbers plus the required diameter.

Packaging

Diaswiss carbide cutters are packed individually.

Recommended speed

Diaswiss carbide cutters achieve best results at speeds below 30,000 rpm.

Fraises en carbure de tungstène

Les instruments en carbure de Diaswiss répondent à toutes les exigences en termes de durée de vie, de capacité de coupe ainsi que d'état de surfaces. Outre les fraises à denture simple et croisée, Diaswiss propose une série de dentures innovantes pour des matériaux et des applications spécifiques. La qualité de la finition des instruments en carbure se distingue par un procédé complexe de brasage qui consiste à introduire la tige de la fraise dans la tête durant cette opération. Nous obtenons par ce procédé une excellente stabilité réduisant ainsi les vibrations et les risques de rupture.

Référence

La référence est indiquée pour chaque article en anglais («Order-No.»). Veuillez s'il vous plaît indiquer à la commande cette référence ainsi que le diamètre.

Conditionnement

Emballage individuel.

Vitesse recommandée

Un résultat optimal est obtenu avec les fraises carbure Diaswiss jusqu'à une vitesse de 30'000 tpm au maximum.

Hartmetallfräser

Diaswiss Hartmetallwerkzeuge lassen in Bezug auf Standzeit, Schneidfreudigkeit, Oberflächenqualität und Sortiment keine Wünsche offen. Neben einfach- und kreuzverzahnten Fräsern bietet Ihnen Diaswiss auch eine Reihe von innovativen Verzahnungen für spezifische Materialien und Anwendungen an. Die Verarbeitungsqualität der Hartmetallwerkzeuge weist interessante Besonderheiten auf, die unmittelbaren Nutzen für Anwender ergeben, hierzu zählt z.B. die komplexe Dauerhartverlötung, bei der der Schaft während des Lötvorgangs in den Hartmetallkopf eingeführt wird. Dies führt zu einer deutlich höheren Stabilität, geringerer Bruchgefahr sowie besserer Laufruhe.

Bestellnummer

Die Bestellnummer ist als „Order-No.“ bei jedem Artikel angegeben, bitte verwenden Sie diese Bestellnummern inkl. der Durchmesserangabe.

Verpackung

Diaswiss Hartmetallfräser werden einzeln verpackt.

Drehzahlempfehlung

Diaswiss Hartmetallfräser erzielen die besten Arbeitsergebnisse bei einer Drehzahl bis maximal 30.000 UpM.

Fresas de carburo de tungsteno

Las fresas de carburo de tungsteno de Diaswiss satisfacen todos los deseos en cuanto a la durabilidad, el rendimiento de corte, la calidad de superficie y la gama. Además de fresas de dentado sencillo y cruzado, Diaswiss le también ofrece una serie de innovadores dentados para materiales e indicaciones especiales. La calidad de fabricación de los instrumentos de carburo de tungsteno posee algunas cualidades especiales que suponen un beneficio directo para el usuario, como, p. ej. la soldadura fuerte, donde el vástago es introducido en la cabeza de carburo de tungsteno durante el proceso de soldadura. De este modo se consigue una estabilidad notablemente superior, un menor peligro de rotura y una mejor suavidad de giro.

Número de pedido

El número de pedido aparece indicado en todos los artículos como "Order-No.". Por favor, utilice este número con indicación del diámetro.

Envase

Las fresas de carburo de tungsteno Diaswiss se suministran en envases individuales.

Velocidad recomendada

Las fresas de carburo de tungsteno de Diaswiss ofrecen los mejores resultados de trabajo hasta una velocidad máxima de 30.000 rpm.

Frese in carburo di tungsteno

Gli strumenti in carburo di tungsteno Diaswiss non lasciano nulla a desiderare in quanto a durata, efficienza di taglio, qualità superficiale e assortimento. Oltre a frese a denti semplici e incrociati, Diaswiss offre anche una serie di tagli innovativi per materiali e applicazioni particolari. La qualità di lavorazione degli strumenti in carburo di tungsteno presenta alcune particolarità che offrono vantaggi immediati per gli utilizzatori, fra queste, ad esempio, il complesso processo di saldatura permanente, durante il quale il gambo viene inserito nella testa in carburo di tungsteno. Ciò produce una stabilità notevolmente superiore, un minor rischio di rotture e una maggiore silenziosità.

Numero d'ordine

Il numero d'ordine è indicato con "Order-No." per ogni articolo. Per ordinazioni si prega di utilizzare questo numero più l'indicazione del diametro.

Confezione

Le frese in carburo di tungsteno Diaswiss vengono confezionate singolarmente.

Numero di giri consigliato

Le frese in carburo di tungsteno Diaswiss ottengono i migliori risultati di lavorazione con un numero di giri massimo di 30.000 giri/min.

ISO codification

The ISO codification consists of 15 digits in 5 groups:

Code ISO

Le code ISO est composé de 15 chiffres répartis en cinq groupes :

ISO-Nummernaufbau

Die ISO-Kodifizierung besteht aus 15 Ziffern, welche in 5 Teilblöcke eingeteilt sind:

Composición del número ISO

La codificación ISO se compone de 15 cifras, divididas en 5 bloques:

Struttura del numero ISO

La codifica ISO è costituita da 15 cifre, suddivise in 5 blocchi:

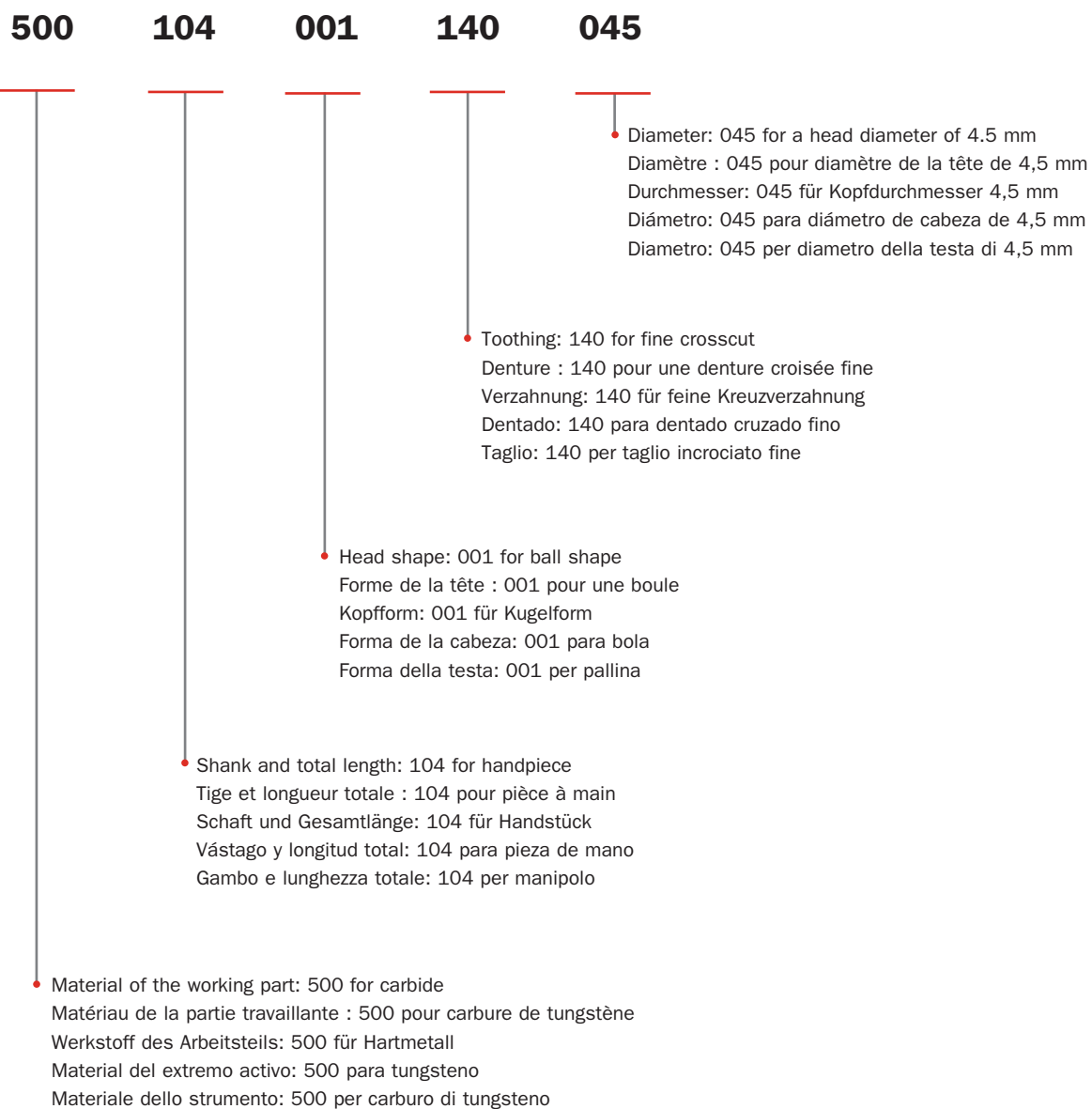

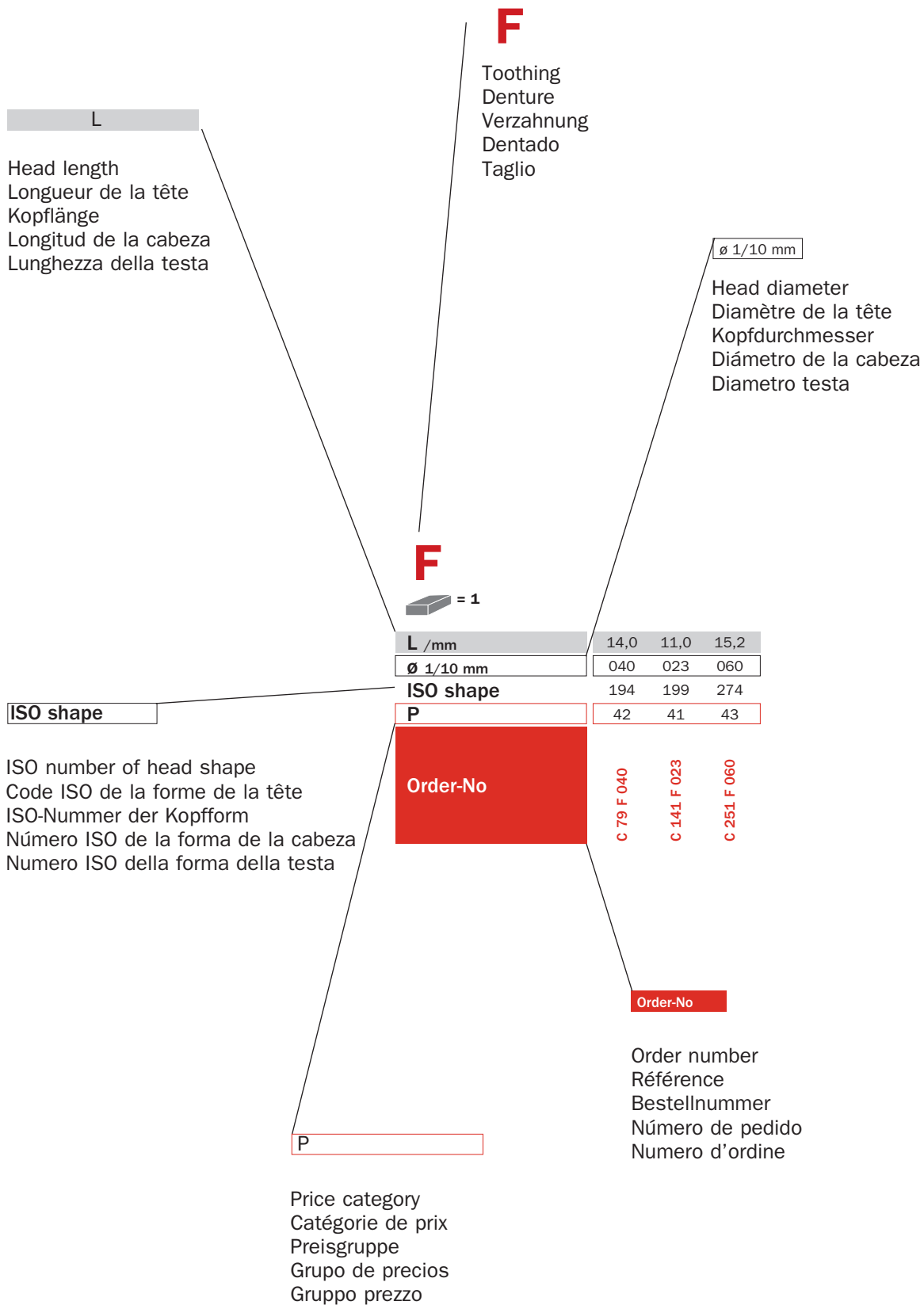

Diaswiss carbide soldering technique

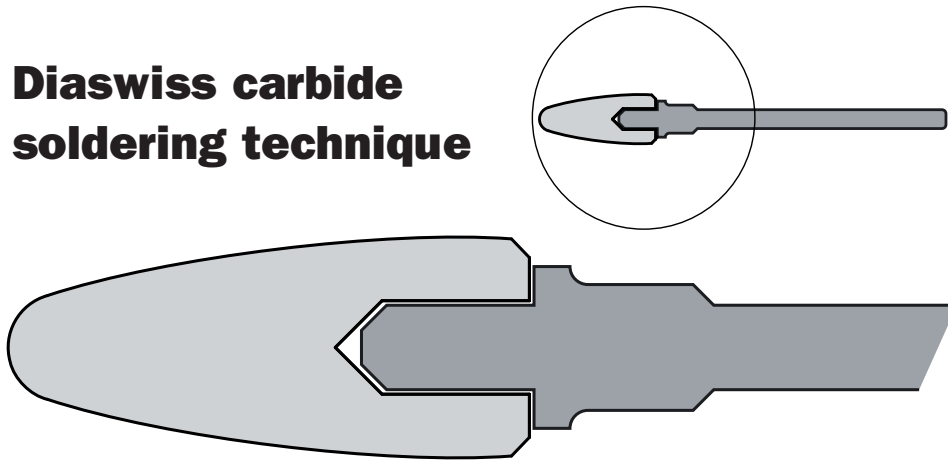

C

Plain cut
Dentado simple

Denture simple
Taglio semplice

Einfachverzahnung



- Precious metals, composites
- Alliages précieux, composites
- Edelmetall, Komposit
- Aleaciones preciosas, resinas compuestas
- Metallo nobile, composito

SF
= 1

L /mm	15,0	13,5	4,2	3,6	16,0	16,0
Ø 1/10 mm	023	045	010	016	023	023
ISO shape	201	194	196	272	145	292
P	45	49	42	43	45	45

Order-No

C 23 SF 023
C 79 SF 045
C 138 SF 010
C 274 SF 016
C 486 SF 023
C 487 SF 023



- Precious metals, composites
- Alliages précieux, composites
- Edelmetall, Komposit
- Aleaciones preciosas, resinas compuestas
- Metallo nobile, composito

F
= 1

L /mm	13,1	10,0	13,7
Ø 1/10 mm	040	023	060
ISO shape	194	199	274
P	42	41	43

Order-No

C 79 F 040
C 141 F 023
C 251 F 060

C

Plain cut Dentado simple

Denture simple Taglio semplice

Einfachverzahnung

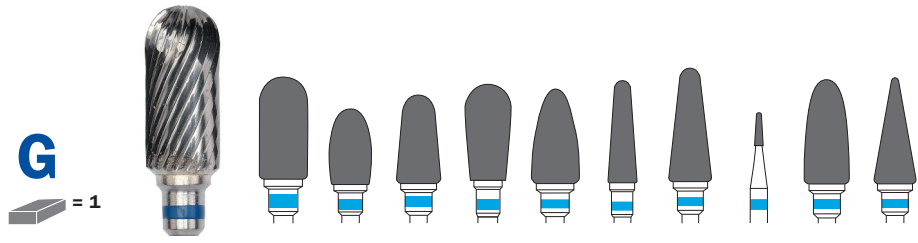

L /mm	13,5	10,0	11,7	12,7	12,5	13,5	15,0	4,2	13,7	14,0
Ø 1/10 mm	060	060	060	060	060	045	060	010	060	060
ISO shape	143	277	260	239	257	194	194	196	275	201
P	48	48	48	48	48	48	48	41	48	48

Order-No	C 72 G 060	C 73 G 060	C 75 G 060	C 77 G 060	C 78 G 060	C 79 G 045	C 79 G 060	C 138 G 010	C 251 G 060	C 416 G 060
----------	------------	------------	------------	------------	------------	------------	------------	-------------	-------------	-------------

- Acrylics, plaster
- Résines, plâtre
- Kunststoff, Gips
- Acrílicos protéticos, yeso
- Resina, gesso

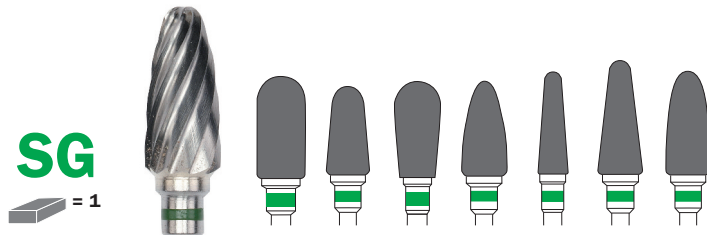

L /mm	13,5	11,7	12,7	12,5	13,5	15,0	13,7
Ø 1/10 mm	060	060	060	060	045	060	060
ISO shape	143	260	239	257	194	194	275
P	51	51	51	51	51	51	51

Order-No	C 72 SG 060	C 75 SG 060	C 77 SG 060	C 78 SG 060	C 79 SG 045	C 79 SG 060	C 251 SG 060
----------	-------------	-------------	-------------	-------------	-------------	-------------	--------------

- Acrylics, plaster
- Résines, plâtre
- Kunststoff, Gips
- Acrílicos protéticos, yeso
- Resina, gesso

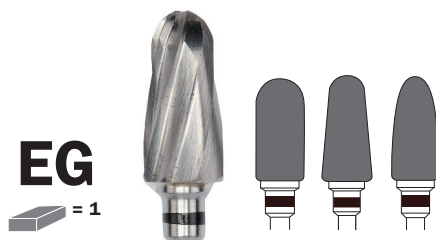

L /mm	13,5	14,0	13,7
Ø 1/10 mm	060	070	060
ISO shape	143	201	275
P	54	54	54

Order-No	C 72 EG 060	C 75 EG 070	C 251 EG 060
----------	-------------	-------------	--------------

- Acrylics, plaster
- Résines, plâtre
- Kunststoff, Gips
- Acrílicos protéticos, yeso
- Resina, gesso

CX

Cross cut
Dentado cruzado

Denture croisée
Taglio incrociato

Kreuzverzahnung

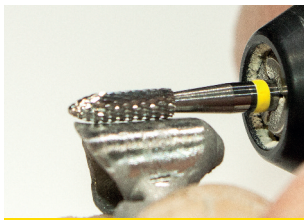

SF
= 1

L /mm	15,0	5,5	5,7	13,5	8,0	8,0	8,0	17,0	16,0	16,0
Ø 1/10 mm	023	023	023	045	016	023	023	023	023	023
ISO shape	201	227	239	194	198	198	289	187	145	292
P	50	50	50	54	49	50	50	50	50	50
Order-No	CX 23 SF 023	CX 30 SF 023	CX 77 SF 023	CX 79 SF 045	CX 138 SF 016	CX 138 SF 023	CX 139 SF 023	CX 257 SF 023	CX 486 SF 023	CX 487 SF 023

- Non-precious and precious alloys, composites
- Alliages précieux et non-précieux, composites
- Edelmetall, Nichtedelmetall, Komposit
- Aleaciones preciosas y no preciosas, resinas compuestas
- Metallo nobile e non nobile, composite



F
= 1

L /mm	15,0	8,0	-	13,5	3,3	10,0	8,5	11,7	5,7	12,7	7,0
Ø 1/10 mm	023	023	023	060	014	060	040	060	023	060	023
ISO shape	201	141	001	143	277	277	198	200	239	239	257
P	47	46	46	53	46	53	52	53	46	53	46
Order-No	CX 23 F 023	CX 24 F 023	CX 71 F 023	CX 72 F 060	CX 73 F 014	CX 73 F 060	CX 75 F 040	CX 75 F 060	CX 77 F 023	CX 77 F 060	CX 78 F 023

- Non-precious and precious alloys, composites
- Alliages précieux et non-précieux, composites
- Edelmetall, Nichtedelmetall, Komposit
- Aleaciones preciosas y no preciosas, resinas compuestas
- Metallo nobile e non nobile, composite

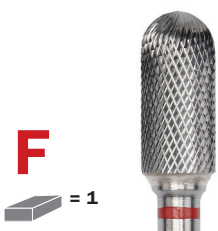

F
= 1

L /mm	8,4	12,5	13,1	13,5	15,0	14,5	8,0	8,0	8,0	13,7	15,0	17,0	16,0	16,0
Ø 1/10 mm	040	060	040	045	060	040	016	023	023	060	060	023	023	023
ISO shape	273	275	194	194	194	201	198	198	289	275	292	187	145	292
P	52	53	47	53	53	47	46	46	46	53	53	47	47	47
Order-No	CX 78 F 040	CX 78 F 060	CX 79 F 040	CX 79 F 045	CX 79 F 060	CX 80 F 040	CX 138 F 016	CX 138 F 023	CX 139 F 023	CX 251 F 060	CX 253 F 060	CX 257 F 023	CX 486 F 023	CX 487 F 023

- Non-precious and precious alloys, composites
- Alliages précieux et non-précieux, composites
- Edelmetall, Nichtedelmetall, Komposit
- Aleaciones preciosas y no preciosas, resinas compuestas
- Metallo nobile e non nobile, composite

CX

Cross cut
Dentado cruzado

Denture croisée
Taglio incrociato

Kreuzverzahnung



- Non-precious alloys, partials, precious alloys, plaster
- Alliages non-précieux et précieux, stellites, plâtre
- Nichtedelmetall, Modellguss, Edelmetall, Gips
- Aleaciones no preciosas y preciosas, esqueléticos, yeso
- Metallo non nobile e nobile, scheletrati, gesso

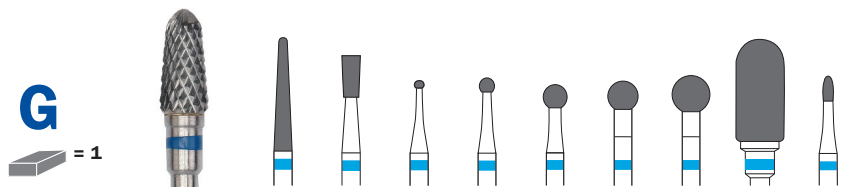

L /mm	15,0	5,5	-	-	-	-	-	13,5	3,3
Ø 1/10 mm	023	023	010	023	031	040	050	060	014
ISO shape	201	227	001	001	001	001	001	143	277
P	46	45	45	45	50	50	50	50	45

Order-No	CX 23 G 023	CX 30 G 023	CX 71 G 010	CX 71 G 023	CX 71 G 031	CX 71 G 040	CX 71 G 050	CX 72 G 060	CX 73 G 014
----------	-------------	-------------	-------------	-------------	-------------	-------------	-------------	-------------	-------------

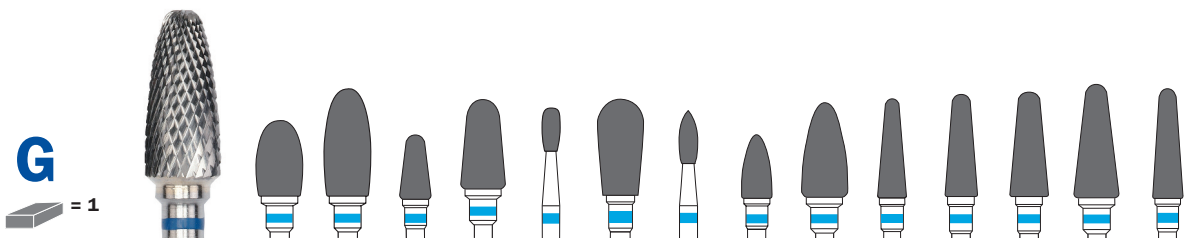

L /mm	10,0	14,2	8,5	11,7	5,7	12,7	7,0	8,4	12,5	13,1	13,5	13,8	15,0	14,5
Ø 1/10 mm	060	060	040	060	023	060	023	040	060	040	045	050	060	040
ISO shape	277	277	198	200	239	239	257	273	275	194	194	194	194	201
P	50	50	49	50	45	50	45	49	50	50	50	50	50	49

Order-No	CX 73 G 060	CX 74 G 060	CX 75 G 040	CX 75 G 060	CX 77 G 023	CX 77 G 060	CX 78 G 023	CX 78 G 040	CX 78 G 060	CX 79 G 040	CX 79 G 045	CX 79 G 050	CX 79 G 060	CX 80 G 040
----------	-------------	-------------	-------------	-------------	-------------	-------------	-------------	-------------	-------------	-------------	-------------	-------------	-------------	-------------

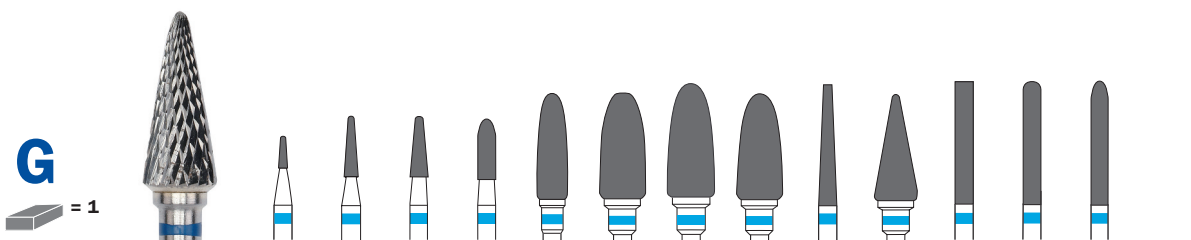

L /mm	4,2	8,0	8,0	8,0	14,0	14,0	15,0	14,0	16,0	14,0	16,0	16,0	16,0
Ø 1/10 mm	010	016	023	023	040	060	060	060	023	060	023	023	023
ISO shape	196	198	198	289	275	275	292	251	187	201	123	145	292
P	42	45	45	45	49	50	50	50	45	50	46	46	46

Order-No	CX 138 G 010	CX 138 G 016	CX 138 G 023	CX 139 G 023	CX 251 G 040	CX 251 G 060	CX 253 G 060	CX 251 L G 060	CX 257 G 023	CX 416 G 060	CX 460 G 023	CX 486 G 023	CX 487 G 023
----------	--------------	--------------	--------------	--------------	--------------	--------------	--------------	----------------	--------------	--------------	--------------	--------------	--------------

CX

Cross cut
Dentado cruzado

Denture croisée
Taglio incrociato

Kreuzverzahnung



- Partial, acrylics, plaster
- Stellites, résines, plâtre
- Modellguss, Kunststoff, Gips
- Esqueléticos, acrílicos protéticos, yeso
- Scheletrati, resina, gesso

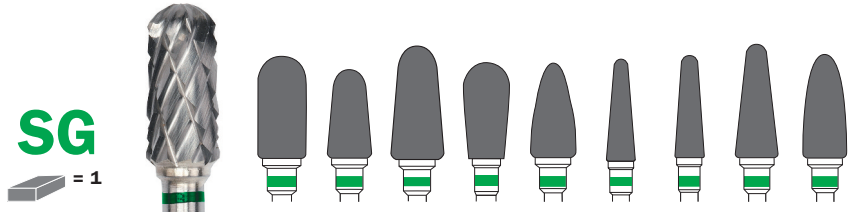

L /mm	13,5	11,7	15,0	12,7	12,5	13,5	13,5	15,0	13,7
Ø 1/10 mm	060	060	070	060	060	040	045	060	060
ISO shape	143	200	201	239	275	194	194	194	275
P	53	53	53	53	53	53	53	53	53

Order-No

CX 72 SG 060
CX 75 SG 060
CX 75 SG 070
CX 77 SG 060
CX 78 SG 060
CX 79 SG 040
CX 79 SG 045
CX 79 SG 060
CX 251 SG 060

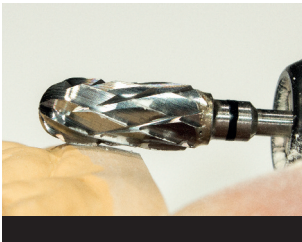

- Acrylics, plaster
- Résines, plâtre
- Kunststoff, Gips
- Acrílicos protéticos, yeso
- Resina, gesso



L /mm	13,5	14,0	13,7
Ø 1/10 mm	060	070	060
ISO shape	143	201	275
P	54	54	54

Order-No

CX 72 EG 060
CX 75 EG 070
CX 251 EG 060

MX

Cross cut straight

Denture croisée droite
Dentado cruzado recto

Kreuzverzahnung gerade
Taglio incrociato diritto



- Acrylics, soft acrylics
- Résines, résines souples
- Kunststoff, weichbleibende Kunststoffe
- Acrílicos, acrílicos blandos
- Resina, resina morbide

F
= 1

L /mm	13,1	13,7
Ø 1/10 mm	040	060
ISO shape	194	275
P	47	53

Order-No

MX 79 F 040L
MX 251 F 060L



Carbide burs for left-handed technicians
Fraises carbures pour gauchers
Hartmetallfräser für Linkshänder
Fresas de carburo para técnicos zurdos
Frese in carburo di tungsteno per mancini

CX

Cross cut
Dentado cruzado

Denture croisée
Taglio incrociato

Kreuzverzahnung



- Non-precious alloys, partials, precious alloys, plaster
- Alliages non-précieux et précieux, stellites, plâtre
- Nichtedelmetall, Modellguss, Edelmetall, Gips
- Aleaciones no preciosas y preciosas, esqueléticos, yeso
- Metallo non nobile e nobile, scheletrati, gesso

G
= 1

L /mm	15,0	13,8	8,0	14,0	16,0
Ø 1/10 mm	023	050	023	060	023
ISO shape	201	194	289	275	145
P	46	50	45	50	46

Order-No

CX 23 G 023L
CX 79 G 050L
CX 139 G 023L
CX 251 G 060L
CX 486 G 023L



Carbide burs for left-handed technicians
Fraises carbures pour gauchers
Hartmetallfräser für Linkshänder
Fresas de carburo para técnicos zurdos
Frese in carburo di tungsteno per mancini



- Acrylics, plaster
- Résines, plâtre
- Kunststoff, Gips
- Acrílicos protéticos, yeso
- Resina, gesso

EG
= 1

L /mm	13,5
Ø 1/10 mm	060
ISO shape	143
P	54

Order-No

CX 72 EG 060L



Carbide burs for left-handed technicians
Fraises carbures pour gauchers
Hartmetallfräser für Linkshänder
Fresas de carburo para técnicos zurdos
Frese in carburo di tungsteno per mancini

CX

Cross cut Tin

Denture croisée Tin
Dentado cruzado Tin

Kreuzverzahnung Tin
Taglio incrociato Tin



F
TiN coating

= 1

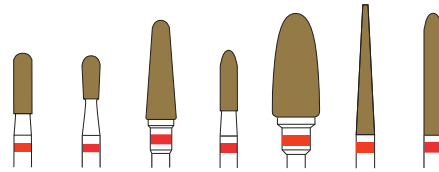

L /mm	8,0	5,7	13,1	8,0	13,7	17,0	16,0
Ø 1/10 mm	023	023	040	023	060	023	023
ISO shape	141	239	194	289	275	187	292
P	50	50	50	50	54	50	50
Order-No	CX 24 F 023 Tin	CX 77 F 023 Tin	CX 79 F 040 Tin	CX 139 F 023 Tin	CX 251 F 060 Tin	CX 257 F 023 Tin	CX 487 F 023 Tin

- Non-precious alloys, precious alloys, composite, zirconia
- Alliages non-précieux et précieux, composites, zircon
- Nichtedelmetall, Edelmetall, Komposite, Zirkon
- Aleaciones no preciosas y preciosas, resinas compuestas, circonio
- Metallo non nobile e nobile, composito, zirconio



G
TiN coating

= 1

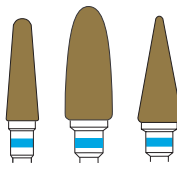

L /mm	13,5	14,0	14,0
Ø 1/10 mm	045	060	060
ISO shape	194	275	201
P	51	51	51
Order-No	CX 79 G 045 Tin	CX 251 G 060 Tin	CX 416 G 060 Tin

- Non-precious alloys, precious alloys, composite, zirconia
- Alliages non-précieux et précieux, composites, zircon
- Nichtedelmetall, Edelmetall, Komposite, Zirkon
- Aleaciones no preciosas y preciosas, resinas compuestas, circonio
- Metallo non nobile e nobile, composito, zirconio



Pin Drill

Fraise pour pins
Broca de pin

Pinbohrer
Fresa fora gessi

TiN coating

= 1



Blade length
Longueur des lames
Schneidenlänge
Longitud de la cuchilla
Lunghezza parte lavorante

L /mm	13,5
Ø mm d ₁	2
Ø mm d ₂	3
P	51
Order-No	1PinDrillTin

- Bur for PINDEX® system, total tool length 35 mm
- Fraise pour système PINDEX®, Longueur totale de l'instrument 35 mm
- Bohrer für PINDEX® System, Gesamtlänge Instrument 35 mm
- Fresa para el sistema PINDEX®, Longitud total del instrumento 35 mm
- Fresa fora gessi per sistema PINDEX®, lunghezza totale 35 mm

PINDEX® is a registered trademark of Coltène/Whaledent, Inc USA
PINDEX® est une marque déposée de Coltène/Whaledent, Inc USA
PINDEX® ist eine eingetragene Marke der Coltène/Whaledent, Inc USA
PINDEX® es una marca registrada de Coltène/Whaledent, Inc USA
PINDEX® è un marchio registrato della società Coltène/Whaledent, Inc USA

AX

Plain cut with spiral groove

Denture hélicoïdale simple
Dentado simple con espiral

Einfachverzahnung mit Spirale
Taglio semplice a spirale



- Non-precious alloys, titanium
- Alliages non-précieux, titane
- Nichtedelmetall, Titan
- Aleaciones no preciosas, titanio
- Metallo non nobile, titanio



L /mm	14,0	13,5	11,5	14,5	16,0
Ø 1/10 mm	023	040	040	060	023
ISO shape	201	194	275	292	292
P	42	43	43	46	42

Order-No

AX 23 F 023
AX 79 F 040
AX 251 F 040
AX 251 F 060
AX 487 F 023

MX

Cross cut straight

Denture croisée droite
Dentado cruzado recto

Kreuzverzahnung gerade
Taglio incrociato diritto



- Acrylics, soft acrylics
- Résines, résines souples
- Kunststoff, weichbleibende Kunststoffe
- Acrílicos, acrílicos blandos
- Resina, resina morbide



L /mm	13,1	8,0	13,7
Ø 1/10 mm	040	023	060
ISO shape	194	198	275
P	47	46	53

Order-No

MX 79 F 040
MX 138 F 023
MX 251 F 060

KX

Plain cut straight with fine spiral groove
Einfachverzahnung gerade mit feiner Spirale

Denture hélicoïdale fine simple, droite
Dentado simple recto con espiral fina
Taglio semplice diritto a spirale fine

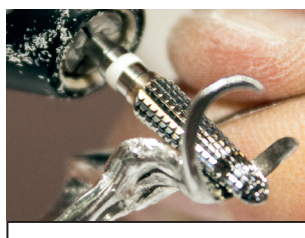

- Non-precious alloys, partials, soft acrylics
- Alliages non-précieux, stellites, résines souples
- Nichtedelmetall, Modellguss, weichbleibende Kunststoffe
- Aleaciones no preciosas, esqueléticos, acrílicos blandos
- Metallo non nobile, scheletrati, resina morbide

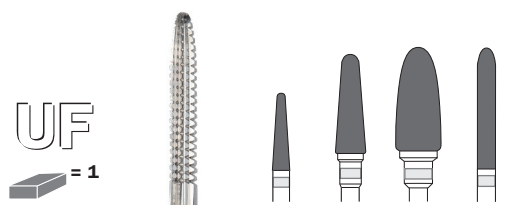

L /mm	10,2	13,1	13,7	16,0
Ø 1/10 mm	023	040	060	023
ISO shape	199	194	275	292
P	46	47	53	46

Order-No

KX 23 UF 023
KX 79 UF 040
KX 251 UF 060
KX 487 UF 023

SX

Plain cut with spiral groove
Dentado simple con espiral

Denture hélicoïdale simple
Taglio semplice a spirale

Einfachverzahnung mit Spirale

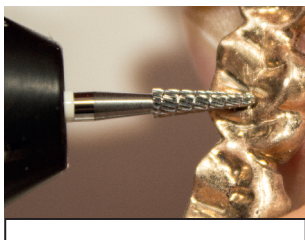

- Precious metals, composite
- Alliages précieux, composites
- Edelmetall, Komposit
- Aleaciones preciosas, resinas compuestas
- Metallo nobile, composito

UF
= 1

L /mm	13,1	8,0	8,0	13,7
Ø 1/10 mm	040	018	023	060
ISO shape	194	198	198	275
P	43	42	42	46

Order-No

SX 79 UF 040
SX 138 UF 018
SX 138 UF 023
SX 251 UF 060

T

Titanium cut
Dentado titanio

Denture titane
Taglio titanio

Titanverzahnung



- Titanium
- Titane
- Titan
- Titanio
- Titanio

F
= 1

L /mm	13,1	13,7
Ø 1/10 mm	040	060
ISO shape	194	275
P	48	52

Order-No

T 79 F 040
T 251 F 060

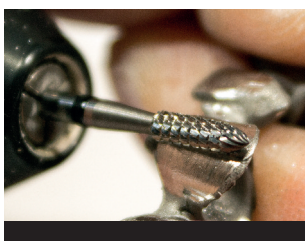

- Titanium
- Titane
- Titan
- Titanio
- Titanio

EG
= 1

L /mm	8,0	13,1	8,0
Ø 1/10 mm	023	040	023
ISO shape	289	194	198
P	46	48	46

Order-No

T 39 EG 023
T 79 EG 040
T 138 EG 023

CX

Cross cut
Dentado cruzado

Denture croisée
Taglio incrociato

Kreuzverzahnung



L /mm	15,0	–	15,0	8,0	8,0	14,0	16,0
Ø 1/10 mm	023	031	060	023	023	060	023
ISO shape	201	001	194	198	289	275	292
P	51	55	55	50	50	55	51

Order-No

CX 23 G 023 IB
CX 71 G 031 IB
CX 79 G 060 IB
CX 138 G 023 IB
CX 139 G 023 IB
CX 251 G 060 IB
CX 487 G 023 IB

- Powernitride coating using the latest coating technology. Significantly enhanced lifetime compared to conventional coatings, reduced friction resistance without loss of cutting efficiency. Smooth running.
- Revêtement Powernitride découlant des dernières avancées technologiques. Augmentation significative de la durée de vie par rapport aux revêtements classiques, réduit de manière significative la résistance au frottement, efficacité augmentée et parfaite concentricité.
- Powernitridbeschichtung in neuester technologischer Ausführung. Signifikant erhöhte Standzeit gegenüber herkömmlichen Beschichtungen, deutlich geringerer Reibungswiderstand bei gleicher Aggressivität und weicherem Rundlauf.

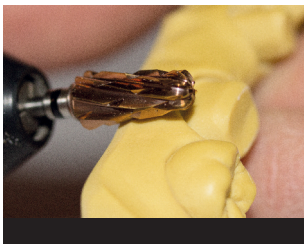

L /mm	14,0
Ø 1/10 mm	070
ISO shape	201
P	55

Order-No

CX 75 EG 070 IB

- Revestimiento con Powernitrid en su más novedosa versión tecnológica. Vida útil significativamente aumentada en comparación con revestimientos tradicionales, resistencia a la fricción reducida pero manteniendo la misma agresividad y ofreciendo una concentricidad más suave.
- Gratie al trattamento speciale Powernitride di superfici, una maggior durata della fresa rispetto alle frese con trattamento tradizionale, riduzione della resistenza di attrito, mantenendo la stessa aggressività e la morbide rifinitura.

AX

Plain cut with spiral groove

Denture hélicoïdale simple
Dentado simple con espiral

Einfachverzahnung mit Spirale
Taglio semplice a spirale



L /mm	14,0	13,5	11,5	14,5	16,0
Ø 1/10 mm	023	040	040	060	023
ISO shape	201	194	275	292	292
P	45	47	47	51	45

Order-No

AX 23 F 023 IB
AX 79 F 040 IB
AX 251 F 040 IB
AX 251 F 060 IB
AX 487 F 023 IB

- Non-precious alloys, titanium
- Alliages non-précieux, titane
- Nichtedelmetall, Titan
- Aleaciones no preciosas, titanio
- Metallo non nobile, titanio

MX

Cross cut straight

Denture croisée droite
Dentado cruzado recto

Kreuzverzahnung gerade
Taglio incrociato diritto



- Acrylics, soft acrylics
- Résines, résines souples
- Kunststoff, weichbleibende Kunststoffe
- Acrílicos, acrílicos blandos
- Resina, resina morbide

F
= 1

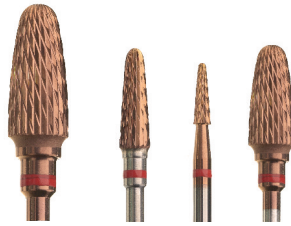

L /mm	13,1	8,0	13,7
Ø 1/10 mm	040	023	060
ISO shape	194	198	275
P	52	51	55

Order-No

MX 79 F 040 IB

MX 138 F 023 IB

MX 251 F 060 IB

KX

Plain cut straight with fine spiral groove
Einfachverzahnung gerade mit feiner Spirale

Denture hélicoïdale fine simple, droite
Dentado simple recto con espiral fina
Taglio semplice diritto a spirale fine

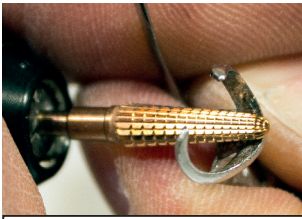

- Non-precious alloys, partials, soft acrylics
- Alliages non-précieux, stellites, résines souples
- Nichtedelmetall, Modellguss, weichbleibende Kunststoffe
- Aleaciones no preciosas, esqueléticos, acrílicos blandos
- Metallo non nobile, scheletrati, resina morbide

UF
= 1



L /mm	10,2	13,1	13,7	16,0
Ø 1/10 mm	023	040	060	023
ISO shape	199	194	275	292
P	51	52	55	51

Order-No

KX 23 UF 023 IB

KX 79 UF 040 IB

KX 251 UF 060 IB

KX 487 UF 023 IB

SX

Plain cut with spiral groove
Dentado simple con espiral

Denture hélicoïdale simple
Taglio semplice a spirale

Einfachverzahnung mit Spirale

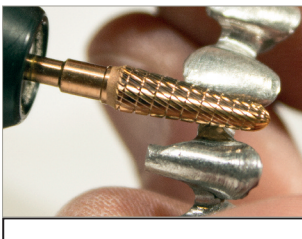

- Precious metals, composite
- Alliages précieux, composites
- Edelmetall, Komposit
- Aleaciones preciosas, resinas compuestas
- Metallo nobile, composito

UF
= 1



L /mm	13,1	13,7
Ø 1/10 mm	040	060
ISO shape	194	275
P	47	51

Order-No

SX 79 UF 040 IB

SX 251 UF 060 IB

CX

Cross cut
Dentado cruzado

Denture croisée
Taglio incrociato

Kreuzverzahnung



NEW

G

= 1

L /mm	15,0	–	3,3	13,8	8,0	14,0	14,0
Ø 1/10 mm	023	040	014	050	023	040	060
ISO shape	201	001	277	194	289	275	275
P	53	55	51	55	51	55	55

Order-No

CX 23 G 023 MB

CX 71 G 040 MB

CX 73 G 014 MB

CX 79 G 050 MB

CX 139 G 023 MB

CX 251 G 040 MB

CX 251 G 060 MB

- DLC coating using the latest coating technology. Significantly enhanced lifetime compared to conventional coatings. Smooth running.
- Revêtement DLC décollant des dernières avancées technologiques. Augmentation significative de la durée de vie par rapport aux revêtements classiques. Parfaite concentricité.
- DLC-Beschichtung in neuester technologischer Ausführung. Signifikant erhöhte Standzeit gegenüber herkömmlichen Beschichtungen. Weicher Rundlauf.
- Revestimiento DLC en su más novedosa versión tecnológica. Vida útil significativamente aumentada en comparación con revestimientos tradicionales. Concentricidad más suave.
- Grazie al trattamento speciale DLC di superfici, una maggior durata della fresa rispetto alle frese con trattamento tradizionale. Morbide rifinitura.



- Thermoplastics, tray material
- Matériaux thermoplastiques et d'empreinte
- Schneiden von Kunststoffen und Löffelmaterial
- Termoplásticos, materiales para cubetas
- Per tagliare e bucare i materiali termoplastici

CC

= 1



L /mm	8,5	10,5	12,5
Ø 1/10 mm	016	023	023
ISO shape	468	468	467
P	41	41	42

Order-No

CC3 016

CC3 023

CC4 023

1

ISO 001

= 6

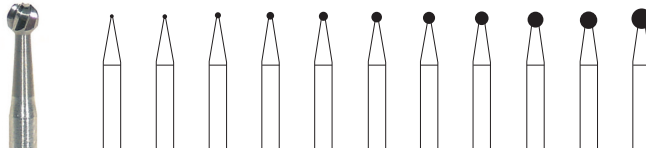

L			-	-	-	-	-	-	-	-	-	-	
S	P	Order-No	Ø 1/10 mm										
HP	31	104 001 ...	005	006	008	010	012	014	016	018	021	023	027
US No.			1/4	1/2	1	2	3	4	5	6	7	8	10

2

ISO 010

= 6



L			1,0	1,0	1,0	1,5	1,5	1,5	2,0
S	P	Order-No	Ø 1/10 mm						
HP	31	104 002 ...	006	008	010	012	014	016	018
US No.			33/2	34	35	36	37	38	39

21

ISO 107

= 6



L			4,5	4,5	5,0
S	P	Order-No	Ø 1/10 mm		
HP	31	104 021 ...	010	012	014
US No.			57	58	59

21R

ISO 137

= 6



L			4,5	4,5
S	P	Order-No	Ø 1/10 mm	
HP	31	104 021R ...	010	012
US No.			1157	1158

23

ISO 168

= 6

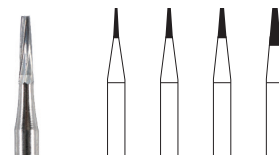

L			4,0	4,0	4,0	5,0
S	P	Order-No	Ø 1/10 mm			
HP	31	104 023 ...	008	010	012	016
US No.			169	170	171	172

23L

ISO 171

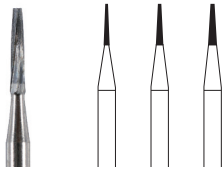

		L	5,5	5,5	5,8
S	P	Order-No	ø 1/10 mm		
HP	31	104 023L ...	009	010	012
		US No.	169L	170L	171L

23R

ISO 194

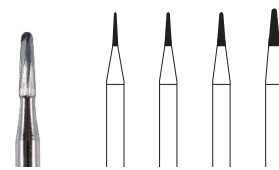

		L	4,5	4,5	4,5	5,0
S	P	Order-No	ø 1/10 mm			
HP	31	104 023R ...	008	010	012	016
		US No.	1169	1170	1171	1172

31

ISO 109

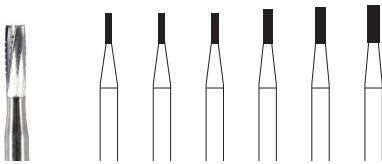

		L	4,0	4,0	4,0	4,5	4,8	5,0
S	P	Order-No	ø 1/10 mm					
HP	31	104 031 ...	008	009	010	012	014	016
		US No.	556	556	557	558	559	560

31L

ISO 110



		L	6,5	6,5
S	P	Order-No	ø 1/10 mm	
HP	31	104 031L ...	010	012
		US No.	557L	558L

31R

ISO 137

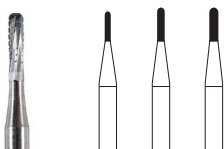

		L	4,0	4,5	4,5
S	P	Order-No	ø 1/10 mm		
HP	31	104 031R ...	008	010	012
		US No.	1556	1557	1558

33

ISO 167

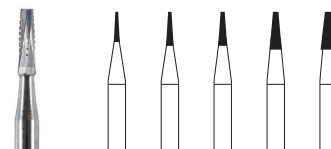

		L	4,0	4,5	4,5	5,0	5,0
S	P	Order-No	ø 1/10 mm				
HP	31	104 033 ...	008	010	012	016	021
		US No.	699	700	701	702	703

33L

ISO 171

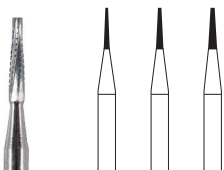

		L	5,5	5,5	5,5	5,5
S	P	Order-No	ø 1/10 mm			
HP	31	104 033L ...	008	010	012	016
		US No.	699L	700L	701L	702L

33R

ISO 194

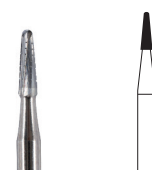

		L	5,0
S	P	Order-No	ø 1/10 mm
HP	31	104 033R ...	016
		US No.	702R

Milling technique

Diaswiss offers instruments for milling technique in various cross-cuts „T“ in both 2.35 mm and 3 mm shanks:

F	Fine	(red ring)
G	Coarse	(blue ring)
SG	Super Coarse	(green ring)

Together with an array of special instruments and polishers, we provide a sensible range of instruments for parallel milling at 0° and for conometry at 2°, 4° and 6° (specified as the angle „A“ for each instrument), which are suitable for all relevant milling technique applications.

Order-No

The order number is indicated as “Order-No.” for each article. Please use these order numbers plus the required diameter.

Packaging

Diaswiss carbide cutters and polishers for milling technique are packed individually.

Recommended speed

Diaswiss carbide cutters for milling technique obtain the best results at speeds of up to 12,000 rpm.

Wax cutters should be used at a maximum of 6,000 rpm; polishers between 5,000 and 10,000 rpm.

Technique de fraisage

Les instruments de fraisage Diaswiss sont offerts avec plusieurs types „T“ de denture en tiges 2,35 mm et 3 mm :

F	fine	(bague rouge)
G	gros	(bague bleue)
SG	supergros	(bague verte)

Notre large gamme d'instruments couvre toutes les techniques de fraisage. Fraisage en parallèle à 0° ainsi que pour une conicité à 2°, 4° et 6° (indiqués comme angle « A » pour chaque instrument).

Référence

La référence est indiquée sur chaque article sous le terme «Order-No», veuillez utiliser ces numéros de commande et indiquer le diamètre.

Emballage

Les fraises en carbure et polissoirs Diaswiss pour la technique de fraisage sont emballés individuellement.

Vitesses recommandées

Les meilleurs résultats sont obtenus à une vitesse allant jusqu'à 12.000 tpm.

Les fraises à cire doivent être utilisées jusqu'à une vitesse de 6.000 tpm maximum, les polissoirs entre 5.000 et 10.000 tpm

Frästechnik

Diaswiss Frästechnikinstrumente werden in verschiedenen Verzahnungen „T“ in 2,35 mm und 3 mm Schaftstärke angeboten:

F	Fein	(roter Ring)
G	Grob	(blauer Ring)
SG	Supergrob	(grüner Ring)

Zusammen mit einer Reihe von Spezialinstrumenten sowie Polierern ergibt sich ein sinnvoll sortiertes Programm von Instrumenten zum Parallelfraßen in 0° sowie für die Konometrie in 2°, 4° und 6° (als „angle“ „A“ bei jedem Instrument angegeben), mit dem alle relevanten Frästechnikanwendungen abgedeckt werden.

Bestellnummer

Die Bestellnummer ist als „Order-No.“ bei jedem Artikel angegeben, bitte verwenden Sie diese Bestellnummern inkl. der Durchmesserangabe.

Verpackung

Diaswiss Hartmetallfräser und Polierer für Frästechnik werden einzeln verpackt.

Drehzahlempfehlung

Diaswiss Hartmetallfräser für Frästechnik erzielen die besten Arbeitsergebnisse bei einer Drehzahl bis 12.000 UpM.

Wachsfräser sollten bei maximal 6.000 UpM eingesetzt werden, Polierer zwischen 5' und 10.000 UpM.

Técnica de fresado

Los instrumentos para el fresado de Diaswiss están disponibles con diferentes niveles „T“ de dentado en vástagos 2,35 mm y 3 mm:

F	Fino	(anillo rojo)
G	Grueso	(anillo azul)
SG	Supergrueso	(anillo verde)

En combinación con una serie de instrumentos especiales y de pulidores se consigue un programa perfectamente surtido de instrumentos para el fresado paralelo en 0° y para la conometría en 2°, 4° y 6° (indicado en cada instrumento como “ángulo” „A”) con el que se cubren todas las indicaciones de la técnica de fresado.

Número de pedido

El número de pedido aparece indicado en todos los artículos como “Order-No.”. Por favor, utilice este número junto con la indicación del diámetro.

Envase

Las fresas de carburo de tungsteno y los pulidores para la técnica de fresado se suministran en envases individuales.

Velocidad recomendada

Las fresas de carburo de tungsteno de Diaswiss para la técnica de fresado ofrecen los mejores resultados de trabajo hasta una velocidad máxima de 12.000 rpm.

Las fresas para cera deben usarse a una velocidad máxima de 6.000 rpm, y los pulidores a una velocidad entre 5.000 y 10.000 rpm.

Tecnica di fresaggio

Gli strumenti Diaswiss per le tecniche di fresaggio in protesi telescopica sono disponibili con diversi tipi „T“ di taglio en gambo di 2,35 mm e di 3 mm:

F	fine	(anello rosso)
G	grossa	(anello blu)
SG	supergrossa	(anello verde)

La gamma è completata da una serie di strumenti speciali e di lucidatori che compongono un assortimento razionale di strumenti per il fresaggio parallelo a 0° e per la conometria con angolo a 2°, 4° e 6° (specificato come “angolo” „A” in ogni strumento) e coprono tutte le applicazioni rilevanti nelle diverse tecniche di fresaggio.

Numero d'ordine

Il numero d'ordine è riportato come „Order-No.” per ogni articolo; si prega di usare questo codice di ordinazione compresi i dati del diametro.

Confezione

Le frese al carburo di tungsteno e i lucidatori Diaswiss per il fresaggio sono confezionati singolarmente.

Velocità consigliata

I migliori risultati si ottengono con una velocità fino a 12.000 giri/min.

Le frese per cera vanno utilizzate a 6.000 giri/min massimo, i lucidatori tra 5' e 10.000 giri/min.

266

Wax cutter



A	0°
L /mm	16,5
Ø 1/10 mm	016
ISO shape	471
P	42

Order-No

266 016

354R

Wax cutters

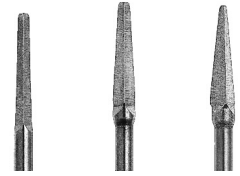

A	2°	4°	6°
L /mm	15,0	14,5	14,0
Ø 1/10 mm	023	030	040
ISO shape	471	471	471
P	42	42	42

Order-No

354R 023

354R 030

354R 040

3681

Wax cutters



A	0°	0°	0°
L /mm	11,0	11,0	11,0
Ø 1/10 mm	010	015	023
ISO shape	137	137	137
P	50	50	50

Order-No

3681 010

3681 015

3681 023

3781

Wax cutters

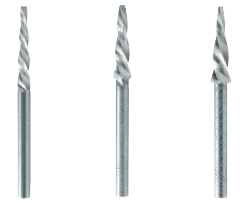

A	2°	4°	6°
L /mm	16,0	15,0	13,5
Ø 1/10 mm	023	031	040
ISO shape	200	200	220
P	50	50	50

Order-No

3781 023

3781 031

3781 040

2635

Milling burs



A	0°	0°	0°	0°	0°	0°	0°	0°	0°
L /mm	9,5	9,5	9,5	10,5	10,5	10,5	16,0	16,0	16,0
Ø 1/10 mm	010	010	010	015	015	015	023	023	023
ISO shape	137	137	137	137	137	137	137	137	137
P	48	48	48	48	48	48	48	48	48
T	SG	G	F	SG	G	F	SG	G	F

Order-No

2635 SG 010

2635 G 010

2635 F 010

2635 SG 015

2635 G 015

2635 F 015

2635 SG 023

2635 G 023

2635 F 023



2535

Milling burs



A	2°	2°	2°	4°	4°	4°	6°	6°	6°
L /mm	15,0	15,0	15,0	13,5	13,5	13,5	14,0	14,0	14,0
Ø 1/10 mm	023	023	023	031	031	031	040	040	040
ISO shape	194	194	200	194	194	200	194	194	200
P	48	48	48	49	49	49	49	49	49
T	SG	G	F	SG	G	F	SG	G	F
Order-No	2535 SG 023	2535 G 023	2535 F 023	2535 SG 031	2535 G 031	2535 F 031	2535 SG 040	2535 G 040	2535 F 040

3266

Shoulder cutting burs



A	0°	0°
L /mm	-	-
Ø 1/10 mm	015	023
ISO shape	138	138
P	42	42

Order-No

3266 015

3266 023

3870

Groove cutters



A	0°	0°	0°	0°
L /mm	7,0	7,0	8,5	10,0
Ø 1/10 mm	010	012	016	020
ISO shape	111	111	111	111
P	45	45	45	45

Order-No

3870 010

3870 012

3870 016

3870 020

7800

Twisters



A	0°	0°
L /mm	9,5	11,5
Ø 1/10 mm	010	015
ISO shape	442	423
P	49	49

Order-No

7800 010

7800 015

7995

Centering punch



A	-
L /mm	4,0
Ø 1/10 mm	009
ISO shape	418
P	48

Order-No

7995 009

Diamill Pol

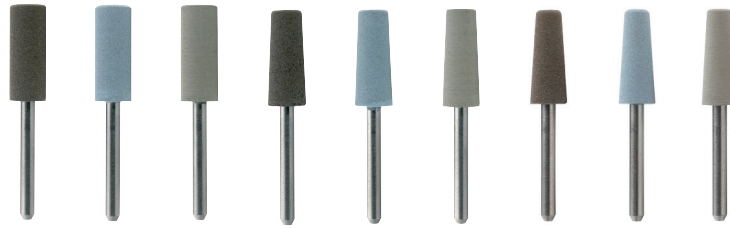

A	0°	0°	0°	2°	2°	2°	4°	4°	4°
L /mm	15,0	15,0	15,0	15,0	15,0	15,0	15,0	15,0	15,0
Ø 1/10 mm	060	060	060	060	060	060	060	060	060
ISO shape	114	114	114	175	175	175	175	175	175
P	44	44	44	44	44	44	44	44	44
1 > 2 > 3	1.	2.	3.	1.	2.	3.	1.	2.	3.
Order-No	900 HP 060	901 HP 060	902 HP 060	910 HP 060	911 HP 060	912 HP 060	920 HP 060	921 HP 060	922 HP 060

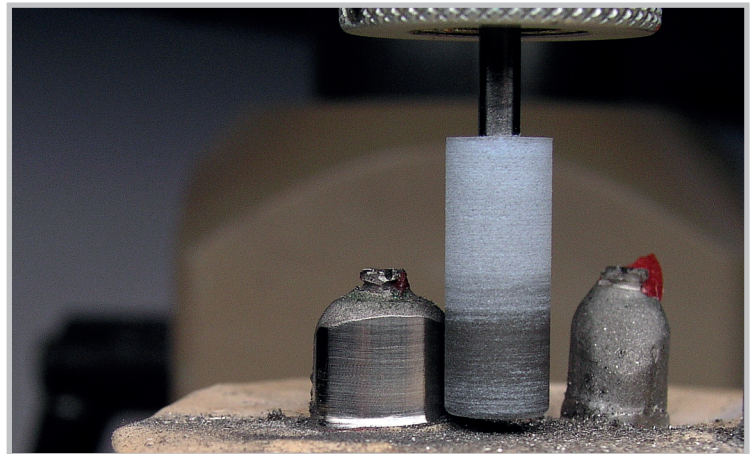

- Shank 3mm
- Tige 3mm
- Schaft 3mm
- Vástago 3mm
- Gambo 3mm

2635-3

Milling burs



A	0°	0°	0°	0°	0°	0°	0°	0°	0°
L /mm	9,5	9,5	9,5	10,5	10,5	10,5	16,0	16,0	16,0
Ø 1/10 mm	010	010	010	015	015	015	023	023	023
ISO shape	137	137	137	137	137	137	137	137	137
P	51	51	51	51	51	51	51	51	51
T	SG	G	F	SG	G	F	SG	G	F
Order-No	2635-3 SG 010	2635-3 G 010	2635-3 F 010	2635-3 SG 015	2635-3 G 015	2635-3 F 015	2635-3 SG 023	2635-3 G 023	2635-3 F 023

Electroplated diamonds

Diaswiss offers a range of exceptional high-quality diamond tools for various applications, especially ceramics. Our tools feature an extremely homogeneous and dense diamond coating, resulting in above-average tool life. We use specially selected natural diamonds to ensure high cutting power. The Diaswiss diamonds are multi-layered and individually embedded. Although this production process is complex, we feel that it is necessary in order to produce a consistent quality which meets and exceeds your expectations.

In addition, we supply diamonds with a spiral diamond design for acrylics, soft reline material and tray materials.

We also offer Diatrim, a specially developed instrument for grinding plaster models with little vibration whereby the design of the diamond coating prevents clogging.

The wire brush wheel is to be used on stippled partial surfaces.

Order-No

The order number is indicated as "Order-No" for each article; please use this order number plus the required diameter. Alternatively, you can also use the ISO head form, grit size and diameter.

Packaging

Diaswiss electroplated diamonds are packed individually or in packs of 6 or 10. Spiral diamonds, Diatrim and the wire brush wheel are packed individually.

Recommended speed:

- Electroplated diamonds: 5' – 30,000 rpm
- Spiral electroplated diamonds: 3' – 15,000 rpm
- Diatrim: 10' – 20,000 rpm
- Wire brush wheel: 1' – 3,000 rpm

Instruments diamantés galvaniques

Diaswiss vous propose des instruments diamantés galvaniques de qualité incomparable pour la céramique. Ils se caractérisent par une distribution extrêmement homogène et dense des diamants, permettant d'offrir une durée de vie de nos instruments supérieure à la moyenne. L'utilisation de diamants naturels garantit une grande capacité de coupe et permet de travailler rapidement et de façon précise. Les instruments Diaswiss sont revêtus de plusieurs couches de diamants à sertissage multiple. Ce processus de fabrication complexe est nécessaire pour obtenir une qualité cohérente à la hauteur de vos exigences et des nôtres.

Nous proposons également des instruments diamantés en spirale pour travailler les acryliques, les résines molles et les matériaux d'empreinte.

Le Diatrim est un instrument spécialement développé pour le façonnage de modèles en plâtre, qui se distingue par son diamantage conçu pour éviter l'encrassement.

La brosse en acier diamanté sert à travailler les surfaces des stellites.

Référence

La référence est indiquée pour chaque article en anglais («Order-No.»). Veuillez s'il vous plaît indiquer à la commande cette référence avec le diamètre. Au lieu de la référence, vous pouvez aussi indiquer dans votre commande le code ISO de la forme de la tête, le grain et le diamètre.

Conditionnement

Les instruments diamantés galvaniques Diaswiss sont conditionnés par 6 ou 10 ou en emballage individuel. Les instruments diamantés spiralés, Diatrim et la brosse en acier diamanté sont emballés individuellement.

Vitesses recommandées :

- Instruments diamantés galvaniques : 5 – 30'000 tpm
- Instruments diamantés galvaniques à spirale : 3 – 15'000 tpm
- Diatrim : 10 – 20'000 tpm
- Brosse en acier diamanté : 1 – 3'000 tpm

Galvanische Diamantwerkzeuge

Diaswiss bietet Diamantwerkzeuge zur Keramikbearbeitung in einzigartiger Qualität an. Unsere Werkzeuge zeichnen sich durch eine extrem homogene und dichte Diamantbeschichtung aus, die überdurchschnittlich hohe Standzeiten ermöglicht. Die Verwendung von besonders ausgesuchten Naturdiamanten sichert eine hohe Schneidfrequenz und ein schnelles und effizientes Arbeiten. Die Diaswiss Diamanten sind mehrfach beschichtet und eingebettet, dieser aufwändige Produktionsprozess ist jedoch notwendig, um eine höchsten Ansprüchen genügende, gleichbleibende Qualität zu erzeugen.

Darüber hinaus bieten wir Diamanten mit spiralisierter Diamantierung zur Bearbeitung von Kunststoffen, weichbleibenden Unterfütterungsmaterialien und Löffelmaterial an.

Eine Besonderheit stellt der Diatrim dar, ein speziell entwickeltes Instrument zum vibrationsarmen Beschleifen von Gipsmodellen, bei dem die Art der Diamantierung ein Verschmieren verhindert.

Die diamantierte Stahldrahtbürste dient zur Bearbeitung von Modellgüßoberflächen.

Bestellnummer

Die Bestellnummer ist als „Order-No.“ bei jedem Artikel angegeben, bitte verwenden Sie diese Bestellnummern inkl. der Durchmesserangabe. Alternativ können Sie unter Angabe der ISO-Kopfform, Körnung und Durchmesser bestellen.

Verpackung

Diaswiss galvanische Diamanten werden einzeln bzw. zu 6 oder zu 10 Stück verpackt. Spiralisierte Diamanten, Diatrim und die Stahldrahtbürste werden einzeln verpackt.

Empfohlene Drehzahl:

- Galvanische Diamanten: 5' – 30.000 UpM
- Galvanische Diamanten mit Spirale: 3' – 15.000 UpM
- Diatrim: 10' – 20.000 UpM
- Stahldrahtbürste: 1' – 3.000 UpM

Instrumentos de diamante galvánicos

Diaswiss le ofrece instrumentos diamantados de calidad exclusiva para el procesamiento de la cerámica. Nuestros instrumentos destacan por su revestimiento diamantado extremadamente homogéneo y compacto, por eso su vida útil es muy superior a la media. El uso de diamantes naturales seleccionados garantiza un alto rendimiento de corte y un trabajo rápido y eficaz. Los cristales de diamante de los instrumentos de Diaswiss están revestidos varias veces y incrustados individualmente. Este complejo proceso de fabricación es necesario para satisfacer su exigencia de una calidad elevada y consistente.

También ofrecemos instrumentos diamantados espiralizados para el procesamiento de materiales sintéticos, materiales de rebase blandos y material para cubeta.

Diatrim es un instrumento singular desarrollado especialmente para tallar modelos de yeso; su tipo de diamantado evita el ensuciamiento.

El cepillo de alambre de acero diamantado sirve para trabajar las superficies de esqueléticos.

Número de pedido

El número de pedido aparece indicado en todos los artículos como "Order-No.". Por favor, utilice este número junto con la indicación del diámetro. Alternativamente puede hacer su pedido indicando la forma de la cabeza ISO, la granulometría y el diámetro.

Envase

Los instrumentos diamantados galvánicos de Diaswiss se suministran en envases de 6 o de 10 unidades. Los instrumentos diamantados espiralizados, Diatrim y el cepillo de alambre se suministran en envases individuales.

Velocidad recomendada:

- Instrumentos diamantados galvánicos: 5.000 – 30.000 rpm
- Instrumentos diamantados galvánicos espiralizados: 3.000 – 15.000 rpm
- Diatrim: 10.000 – 20.000 rpm
- Cepillo de alambre de acero diamantado: 1.000 – 3.000 rpm

Strumenti diamantati galvanizzati

Diaswiss offre strumenti diamantati per la lavorazione della ceramica di eccezionale qualità. I nostri strumenti si distinguono per il loro rivestimento diamantato estremamente omogeneo e compatto, che consente una vita operativa superiore alla media. L'uso di diamanti naturali appositamente scelti assicura un'elevata propensione al taglio e una lavorazione rapida ed efficiente. I diamanti Diaswiss sono più volte rivestiti e incorporati; questo complesso processo produttivo è però necessario per raggiungere una qualità consistente che soddisfi le vostre e le nostre esigenze.

Inoltre offriamo diamanti con diamantatura a spirale, per la lavorazione delle resine, dei materiali morbidi per ribasatura e dei materiali da impronta.

Diatrim rappresenta uno strumento eccezionale, realizzato appositamente per la fresatura dei modelli in gesso, nei quali il tipo di diamantatura impedisce l'impasto con il materiale usato.

La spazzola in metallo diamantata permette di prelucidare le superficie degli scheletrati.

Numero d'ordine

Il numero d'ordine è riportato come „Order-No.“ per ogni articolo; si prega di usare questo codice di ordinazione compresi i dati del diametro. In alternativa, è possibile ordinare immettendo la forma della testa, la struttura della grana e il diametro ISO.

Confezione

I diamanti galvanizzati Diaswiss sono disponibili singolarmente o in confezioni da 6 o da 10 pezzi. I diamanti a spirale, Diatrim e la spazzola sono confezionati singolarmente.

Numero di giri consigliato:

- Strumenti diamantati galvanizzati: 5' – 30.000 GpM
- Diamanti galvanizzati a spirale: 3' – 15.000 GpM
- Diatrim: 10' – 20.000 GpM
- Spazzola in metallo diamantata: 1' – 3.000 GpM

ISO codification

The ISO codification consists of 15 digits in 5 groups:

Code ISO

Le code ISO est composé de 15 chiffres répartis en cinq groupes :

ISO-Nummernaufbau

Die ISO-Kodifizierung besteht aus 15 Ziffern, welche in 5 Teilblöcke eingeteilt sind:

Composición del número ISO

La codificación ISO se compone de 15 cifras, divididas en 5 bloques:

Struttura del numero ISO

La codifica ISO è costituita da 15 cifre, suddivise in 5 blocchi:

806

104

001

524

012

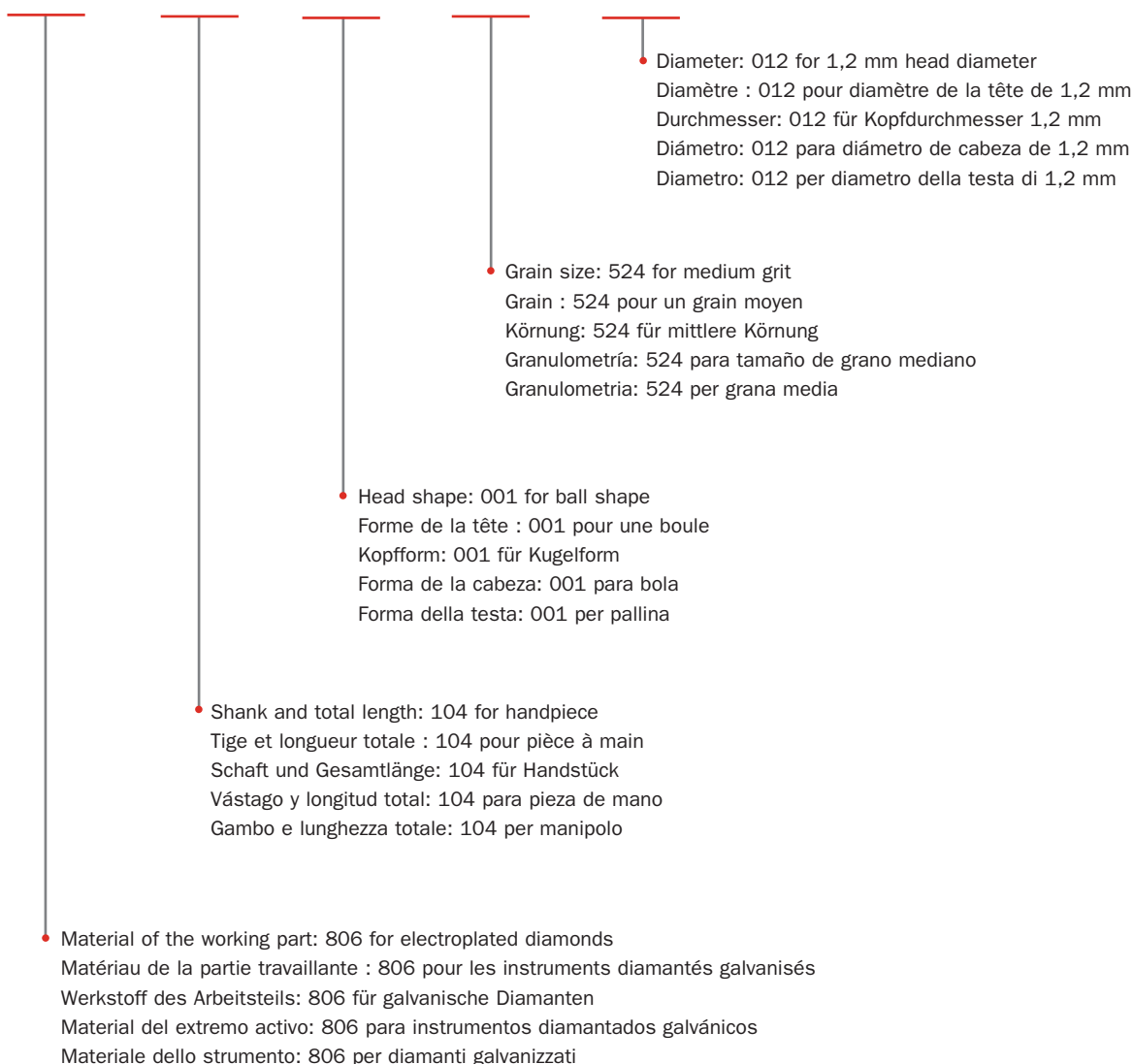

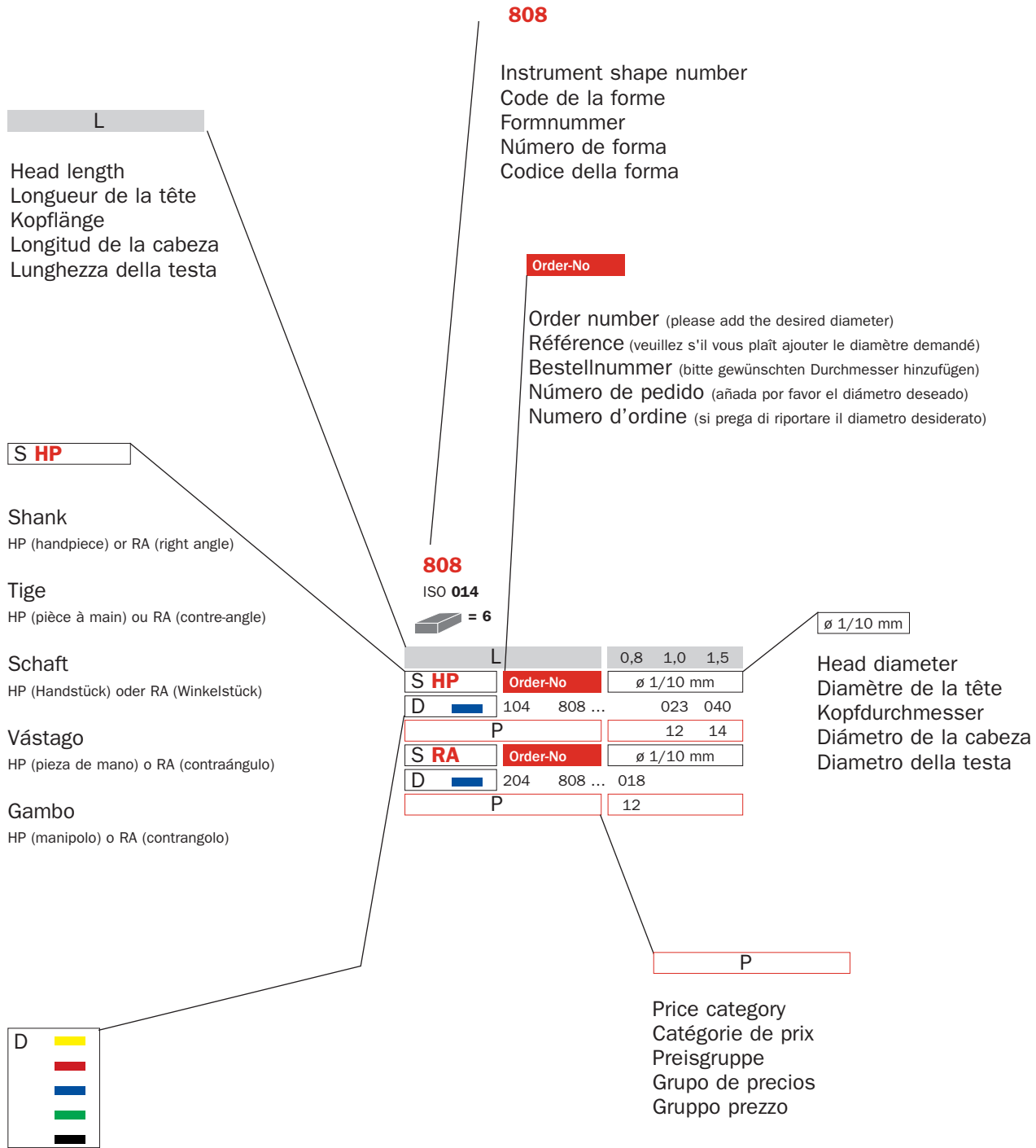

Diamond coating

Yellow (C): superfine ISO 504; Red (F): fine ISO 514; Blue: medium (Standard) ISO 524; Green (G): coarse ISO 534; Black (SG): supercoarse ISO 544

Diamantage

Jaune (C): superfin ISO 504; Rouge (F): fin ISO 514; Bleu: moyen (standard) ISO 524; Vert (G): gros ISO 534; Noir (SG): supergros ISO 544

Diamantierung

Gelb (C): superfein ISO 504; Rot (F): fein ISO 514; Blau: mittel (Standard) ISO 524; Grün (G): grob ISO 534; Schwarz (SG): supergrob ISO 544

Diamantado

Amarillo (C): superfino ISO 504; Rojo (F): fino ISO 514; Azul: mediano (estándar) ISO 524; Verde (G): grueso ISO 534; Negro (SG): supergrueso ISO 544

Diamantatura

Giallo (C): superfine ISO 504; Rosso (F): fine ISO 514; Blu: media (standard) ISO 524; Verde (G): grossa ISO 534; Nero (SG): supergrossa ISO 544

801
ISO 001
= 6

L	-	-	-	-	-	-	-	-	-	-	-	-	-	-
S HP	Order-No	ø 1/10 mm												
D	104 801 ...	009	010	012	014	016	018	021	023	029	035	040	042	
P		11	11	11	11	11	11	12	12	14	14	14	14	

805
ISO 010
= 6

L	2,0	2,0	2,5	3,0	3,0	3,0	3,0	
S HP	Order-No	ø 1/10 mm						
D	104 805 ...	010	012	014	016	018	023	025
P		11	11	11	11	11	12	13

807
ISO 225
= 6

L	5,5	6,0	6,0	
S HP	Order-No	ø 1/10 mm		
D	104 807 ...	018	023	025
P		11	12	13

808
ISO 014
= 6

L	1,0	1,5	
S HP	Order-No	ø 1/10 mm	
D	104 808 ...	023	040
P		12	14

809
ISO 151
= 6

L	3,0		
S HP	Order-No	ø 1/10 mm	
D	104 809 ...	018	
P		11	

818
ISO 040
= 6

L	1,0	1,0	1,1	
S HP	Order-No	ø 1/10 mm		
D	104 818 ...	033	040	050
P		14	14	14

820
ISO 041
= 6

L	1,0		
S HP	Order-No	ø 1/10 mm	
D	104 820 ...	040	
P		14	

825
ISO 304
= 6

L	1,0		
S HP	Order-No	ø 1/10 mm	
D	104 825 ...	025	
P		12	

831
ISO 266
= 6

L	14,5		
S HP	Order-No	ø 1/10 mm	
D	104 SG 831 ...	050	
P		14	

835
ISO 109

L 5,0 5,0 5,0

S HP	Order-No	ø 1/10 mm
D	104 835 ...	010 012 016
P		11 11 11

836
ISO 110

L 7,0

S HP	Order-No	ø 1/10 mm
D	104 836 ...	025
P		13

837
ISO 111

L 8,5 9,5 9,5

S HP	Order-No	ø 1/10 mm
D	104 837 ...	012 014 016
P		11 11 11

840
ISO 111

L 8,0 9,0 9,0 7,0

S HP	Order-No	ø 1/10 mm
D	104 840 ...	033 040 050 070
P		14 14 14 14

841
ISO 112

L 10,5

S HP	Order-No	ø 1/10 mm
D	104 841 ...	018
P		11

842R
ISO 143

L 12,5

S HP	Order-No	ø 1/10 mm
D	104 842R ...	018
	104 SG 842R ...	018
P		11

845
ISO 170

L 5,2 4,5

S HP	Order-No	ø 1/10 mm
D	104 845 ...	010 014
P		11 11

847
ISO 171

L 8,0 6,0

S HP	Order-No	ø 1/10 mm
D	104 847 ...	025 033
P		13 14

848
ISO 172

L 8,5 8,5 9,0 9,5

S HP	Order-No	ø 1/10 mm
D	104 848 ...	016 018 033 040
	104 G 848 ...	018
P		11 11 14 14

849
ISO 196

L 4,5 5,0

S HP	Order-No	ø 1/10 mm
D	104 849 ...	009 016
P		11 11

850
ISO 199

= 6

L	10,0	10,0	10,0	10,0
S HP	Order-No ø 1/10 mm			
D	104 850 ...	014	016	025 040
P	11 11 13 14			

852
ISO 160

= 6

L	4,5	6,0
S HP	Order-No ø 1/10 mm	
D	104 852 ...	010 023
P	11 12	

858
ISO 165

= 6

L	8,0	8,2	8,2
S HP	Order-No ø 1/10 mm		
D	104 858 ...	012 014	016
P	11 11 11		

859
ISO 166

= 6

L	10,0	10,0	10,0	10,0
S HP	Order-No ø 1/10 mm			
D	104 F 859 ...		018 025	
D	104 859 ...	014 016	018 025	
P	11 11 11 13			

860
ISO 245

= 6

L	5,0	5,0
S HP	Order-No ø 1/10 mm	
D	104 F 860 ...	012
D	104 860 ...	014
P	11 11	

862
ISO 249

= 6

L	8,5	8,5
S HP	Order-No ø 1/10 mm	
D	104 862 ...	012 018
P	11 11	

863
ISO 250

= 6

L	10,0	10,0	10,2
S HP	Order-No ø 1/10 mm		
D	104 F 863 ...	012 016	
D	104 863 ...	010 012 016	
D	104 G 863 ...	012 016	
P	11 11 11		

881
ISO 141

= 6

L	7,5	8,0
S HP	Order-No ø 1/10 mm	
D	104 881 ...	016 040
P	11 14	

889
ISO 540

= 6

L	4,0
S HP	Order-No ø 1/10 mm
D	104 889 ... 010
P	11

368
ISO 257

= 6

L	5,5
S HP	Order-No ø 1/10 mm
D	104 F 368 ... 023
D	104 368 ... 023
P	12

Diamond instrument for acrylic dentures



Instrument diamanté pour prothèses acryliques

Diamantwerkzeug für Prothesenkunststoffe

Instrumento diamantado para acrílicos protéticos

Strumento diamantato per resine protetiche

D104
ISO 104

L	3,0
S HP	Order-No
D	104 D104 ...
P	14

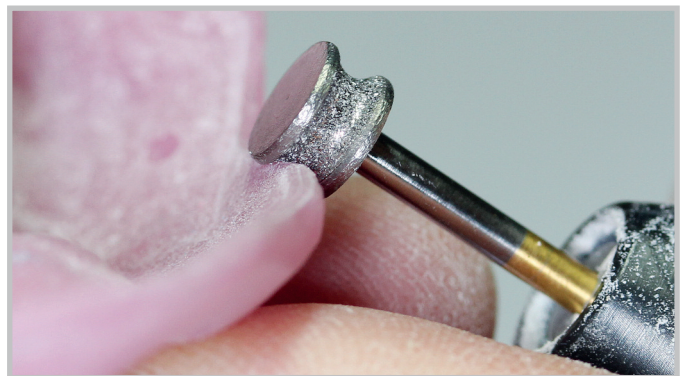

Turbo diamonds with spiral

Fraises diamantées avec spirale

Turbodiamanten mit Spirale

Fresas diamantadas con espiral

Frese diamantate a spirale





T852
ISO 200





L	13,0	15,0	14,5
S HP	Order-No	ø 1/10 mm	
D	104 SG T852 ...	027	043
P		100	101

T852L
ISO 201

L	15,0
S HP	Order-No
D	104 SG T852L ...
P	100

T879L
ISO 291

L	15,5
S HP	Order-No
D	104 SG T879L ...
P	100

Diatrim

837

ISO 201



L	12,2
S HP	Order-No
D	104 SG 837 ...
P	102

879

ISO 114



L	14,5
S HP	Order-No
D	104 SG 879 ...
P	102

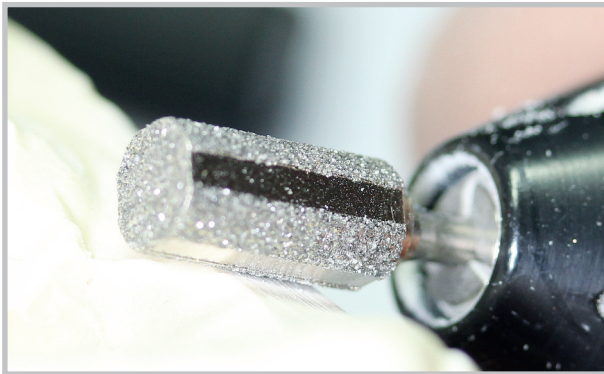

Wire brush wheel

Brosse en acier diamanté

Stahldrahtbürste

Cepillo de alambre de acero diamantado

Spazzola in metallo diamantata

950

Diamond coated

ISO 543



L	—
S HP	Order-No
D	104 SF 950 ...
P	16



Sintered diamonds

The "Diamass" range of sintered diamonds includes a number of particularly powerful sintered diamonds with coarse and extra-coarse diamond grit in addition to a broad selection of instruments in fine and superfine grit. In conjunction with a high diamond concentration, which is progressively exposed during grinding, the specially developed metal bond results in significantly improved tool life and high cutting power. The use of sintered diamonds is recommended in particular for non-precious metals, especially partial frameworks (extracoarse to fine) and for ceramics (fine to superfine).

Diamass sintered diamonds are available with the following diamond grit:

SF	Superfine (yellow ring)	70 µm
F	Fine (red ring)	100 µm
G	Medium (blue ring)	165 µm
SG	Coarse (green ring)	200 µm
EG	Extracoarse (black ring)	250 µm

Order-No

The order number is indicated as "Order-No." for article; please use these order numbers plus the required diameter.

Packaging

Diamass sintered diamonds are packed individually.

Recommended speed

The best results with Diamass sintered diamonds are achieved at a speed between 15' and 30.000 rpm.

Sintered diamond discs should be used at 3' - 15.000 rpm.

Instruments diamantés frittés

La gamme «Diamass» comprend des instruments particulièrement performants, à grain gros et extragros, ainsi qu'une sélection d'instruments fins et superfins. Le procédé de production utilisant un liant métallique spécialement développé à cet effet, combiné à une densité élevée de diamants, permet une excellente qualité de meulage ainsi qu'une amélioration de la durée de vie de ces produits. Les instruments diamantés frittés sont recommandés pour les alliages non-précieux particulièrement pour les stellites (grain extragros à fin) ainsi que pour la céramique (grain fin à superfine).

Les instruments diamantés frittés Diamass sont disponibles dans les diamantages suivants :

SF	superfin (bague jaune)	70 microns
F	fin (bague rouge)	100 microns
G	moyen (bague bleue)	165 microns
SG	gros (bague verte)	200 microns
EG	extragros (bague noire)	250 microns

Référence

La référence est indiquée pour chaque article en anglais («Order-No.»). Veuillez s'il vous plaît indiquer à la commande cette référence ainsi que le diamètre.

Conditionnement

Les instruments diamantés frittés Diamass sont emballés individuellement.

Vitesse recommandée

Des résultats optimaux sont obtenus avec les instruments diamantés frittés Diamass à une vitesse de 15' à 30'000 tpm.

La vitesse recommandée pour les disques Diamass est de 3' - 15'000 tpm.

Sinterdiamanten

Die Diaswiss Sinterdiamanten „Diamass“ umfassen besonders leistungsfähige Sinterdiamanten in grober und extragrober Diamantkörnung sowie weitere Instrumente in feiner und superfeiner Körnung. Die speziell entwickelte Metallbindung verbunden mit einer hohen Diamantkonzentration, welche durch das Schleifen sukzessive freigesetzt wird, führt zu einer deutlich verbesserten Standzeit und hoher Schneidleistung. Der Einsatz von Sinterdiamanten empfiehlt sich bei der Bearbeitung von Nichtelegierungen, insbesondere Modellguss (extragrob bis fein) sowie für die Bearbeitung von Keramik (fein bis superfein).

Diamass Sinterdiamanten sind in folgenden Diamantierungen verfügbar:

SF	Superfein (gelber Ring)	70 micron
F	Fein (roter Ring)	100 micron
G	Mittel (blauer Ring)	165 micron
SG	Grob (grüner Ring)	200 micron
EG	Extragrob (schwarzer Ring)	250 micron

Bestellnummer

Die Bestellnummer ist als „Order-No.“ bei jedem Artikel angegeben, bitte verwenden Sie diese Bestellnummern inkl. der Durchmesserangabe.

Verpackung

Diamass Sinterdiamanten werden einzeln verpackt.

Drehzahlempfehlung

Diamass Sinterdiamanten erzielen die besten Arbeitsergebnisse bei einer Drehzahl zwischen 15' und 30.000 UpM.

Sinterdiamantscheiben sollten bei einer Drehzahl von 3' - 15.000 UpM eingesetzt werden.

Instrumentos de diamante macizo

Los instrumentos de diamante macizo “Diamass” contienen instrumentos de diamante macizo con una granulometría gruesa y extragruosa especialmente eficaces, así como formas en grano fino y superfino. El enlace metálico es un desarrollo especial que, unido a una elevada concentración de diamante que se libera de forma sucesiva durante el tallado, permite obtener una durabilidad notablemente mejorada y un mayor rendimiento de corte. El uso de los instrumentos de diamante macizo está recomendado para aleaciones no preciosas especialmente esqueléticos (granulación extragruosa a fina) y el procesado de la cerámica (granulación fina a superfina).

Los instrumentos de diamante macizo están disponibles con los siguientes tamaños de granulometría:

SF	Superfino (anillo amarillo)	70 micrones
F	Fino (anillo rojo)	100 micrones
G	Medio (anillo azul)	165 micrones
SG	Grueso (anillo verde)	200 micrones
EG	Extragruoso (anillo negro)	250 micrones

Número de pedido

El número de pedido aparece indicado en todos los artículos como “Order-No.”. Por favor, utilice este número junto con la indicación del diámetro.

Envase

Los instrumentos de diamante macizo Diamass se suministran en envases individuales.

Velocidad recomendada

Los instrumentos de diamante macizo Diamass ofrecen los mejores resultados de trabajo a una velocidad entre 15.000 y 30.000 rpm.

Los discos de diamante macizo deben ser utilizados a una velocidad entre 3.000 y 15.000 rpm.

Strumenti diamantati sinterizzati

La gamma degli strumenti diamantati sinterizzati Diaswiss „Diamass“ contiene strumenti diamantati sinterizzati particolarmente versatili a grana grossa e extragrossa, e una varietà di forme a grana fine e superfine. La lega metallica di speciale realizzazione assieme all'elevata concentrazione del diamante, che viene gradualmente liberato dalla levigatura, porta a una vita operativa sensibilmente migliorata ed a prestazioni di taglio più elevate. Si raccomanda l'impiego degli strumenti diamantati sinterizzati nella lavorazione delle leghe di metalli non nobili, soprattutto scheletrati (da extragrossa a fine) e della ceramica (da fine a superfine).

Gli strumenti diamantati sinterizzati Diamass sono disponibili nelle seguenti grane:

SF	Superfine (anello giallo)	70 micron
F	Fine (anello rosso)	100 micron
G	Media (anello blu)	165 micron
SG	Grossa (anello verde)	200 micron
EG	Extragrossa (anello nero)	250 micron

Numero d'ordine

Il numero d'ordine è riportato come „Order-No.“ per ogni articolo; si prega di usare questo codice di ordinazione compresi i dati del diametro.

Confezione

Gli strumenti diamantati sinterizzati sono confezionati singolarmente.

Numero di giri consigliato

Gli strumenti diamantati sinterizzati Diamass raggiungono le migliori prestazioni con un numero di giri compreso fra 15' e 30.000 GpM. I dischi sinterizzati devono essere utilizzati entre 3' e 15.000 GpM.

ISO codification

The ISO codification consists of 15 digits in 5 groups:

Code ISO

Le code ISO est composé de 15 chiffres répartis en cinq groupes :

ISO-Nummernaufbau

Die ISO-Kodifizierung besteht aus 15 Ziffern, welche in 5 Teilblöcke eingeteilt sind:

Composición del número ISO

La codificación ISO se compone de 15 cifras, divididas en 5 bloques:

Struttura del numero ISO

La codifica ISO è costituita da 15 cifre, suddivise in 5 blocchi:

807

104

112

543

045

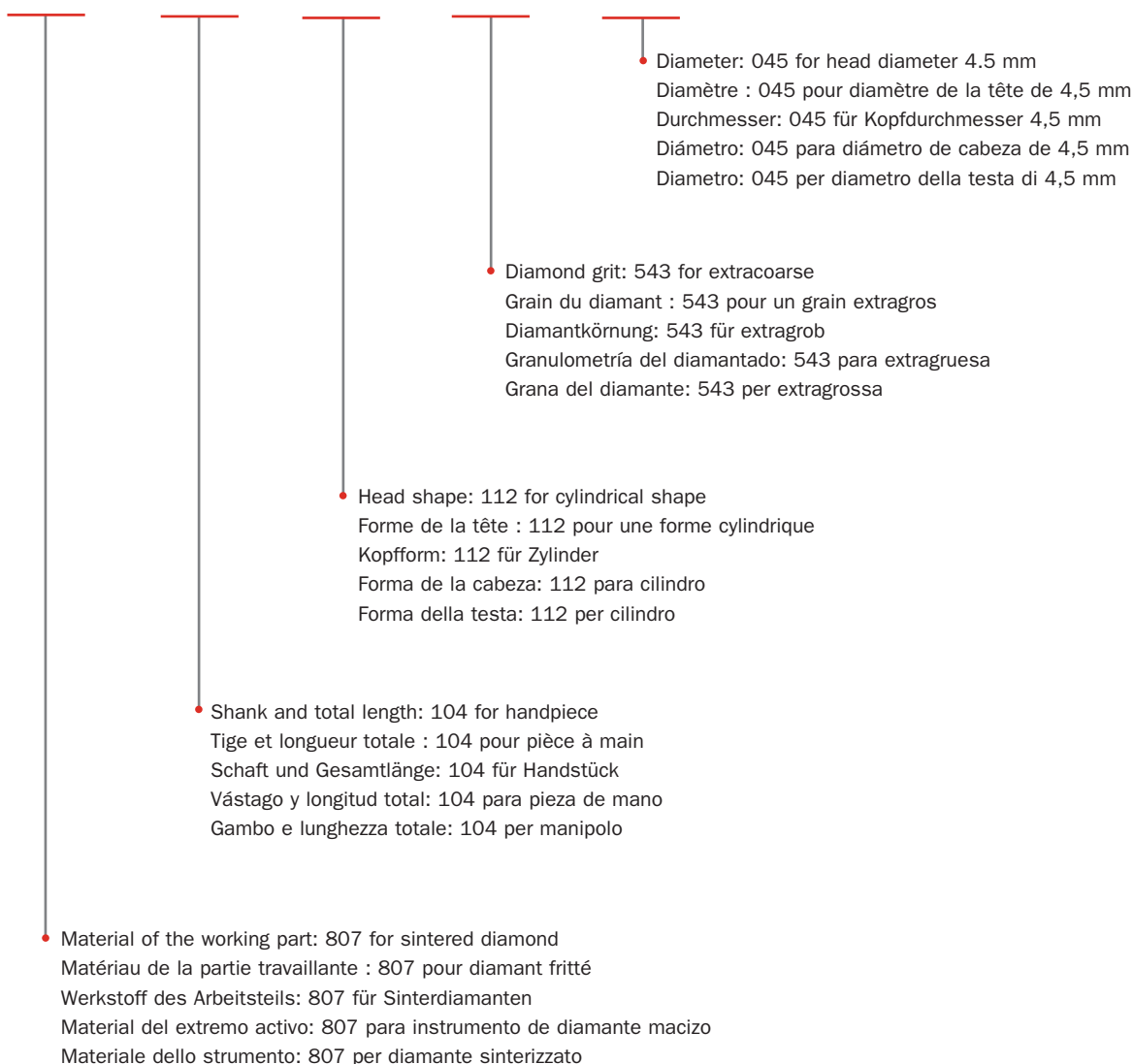

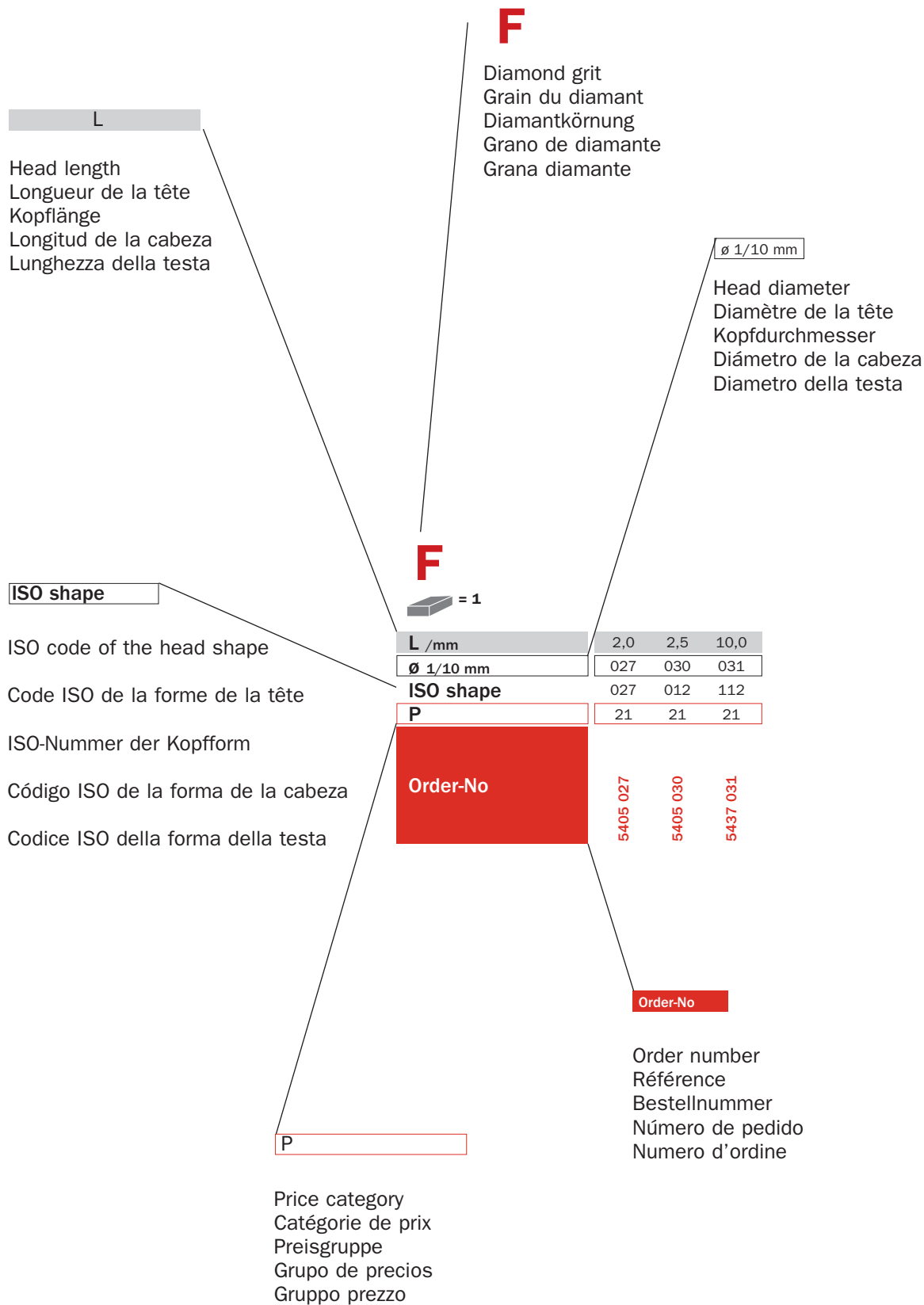

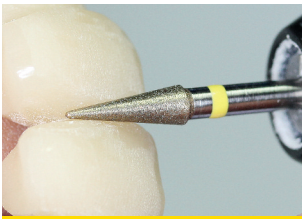

SF



- Ceramics, Co-Cr alloys
- Céramique, alliages Co-Cr
- Keramik, Co-Cr Legierungen
- Cerámica, aleaciones de cromo-cobalto
- Ceramica, leghe Co-Cr

L /mm	3,0	3,3	8,0	15,0	10,0	13,0	9,5	9,5	7,5	13,0
Ø 1/10 mm	018	047	016	050	031	050	031	031	016	050
ISO shape	012	014	140	155	166	167	172	198	248	200
P	21	21	21	22	21	22	21	21	21	22

Order-No

4705 018
4705 047
4738 016
4738 050
4745 031
4745 050
4746 031
4756 031
4760 016
4779 050



F



- Ceramics, Co-Cr alloys
- Céramique, alliages Co-Cr
- Keramik, Co-Cr Legierungen
- Cerámica, aleaciones de cromo-cobalto
- Ceramica, leghe Co-Cr

L /mm	2,0	7,0	13,0	13,0	12,5	9,0	12,5	9,0	10,0	12,0	3,5
Ø 1/10 mm	027	016	050	060	025	031	023	031	016	050	047
ISO shape	027	140	155	274	143	166	200	198	250	200	027
P	21	21	22	23	21	21	21	21	21	22	21

Order-No

5405 027
5438 016
5438 050
5439 060
5442R 025
5445 031
5452 023
5456 031
5463 016
5479 050
5704 047



F



- Ceramics, Co-Cr alloys
- Céramique, alliages Co-Cr
- Keramik, Co-Cr Legierungen
- Cerámica, aleaciones de cromo-cobalto
- Ceramica, leghe Co-Cr

L /mm	5,5	10,5	0,6	13,0	12,5	7,0	9,5	13,0	13,5
Ø 1/10 mm	080	035	080	050	031	016	031	050	080
ISO shape	023	227	303	167	200	248	249	249	274
P	24	21	24	22	22	21	21	22	24

Order-No

5704 080
5707 035
5718 080
5745 050
5756L 031
5760 016
5762 031
5762 050
5762 080



G



- Ceramics, Co-Cr alloys
- Céramique, alliages Co-Cr
- Keramik, Co-Cr Legierungen
- Cerámica, aleaciones de cromo-cobalto
- Ceramica, leghe Co-Cr

L /mm	-	3,0	13,5	12,5	13,0	12,0	9,0	12,5	13,0	13,0	13,0
Ø 1/10 mm	035	047	050	050	060	023	031	031	050	080	050
ISO shape	001	014	112	155	274	200	198	200	251	274	200
P	21	21	22	22	23	21	21	22	22	24	22

Order-No

5801 035
5805 047
5837 050
5838 050
5839 060
5852 023
5856 031
5856L 031
5862 050
5862 080
5879 050





SG



L /mm	10,0	13,0	12,5	10,0
Ø 1/10 mm	050	060	050	030
ISO shape	112	275	161	249
P	23	23	23	22

Order-No

5937 050
5939 060
5945 050
5962 030

- Co-Cr alloys, non precious and semi precious alloys
- Alliages Co-Cr, alliages précieux et semi-précieux
- Co-Cr Legierungen, NE-Legierungen, reduzierte Edelmetalllegierungen
- Aleaciones de cromo-cobalto, aleaciones no preciosas y semi-preciosas
- Leghe Co-Cr, leghe non nobili e leghe seminobili

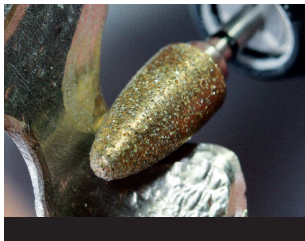

EG



L /mm	10,0	13,0
Ø 1/10 mm	050	060
ISO shape	112	275
P	23	23

Order-No

6037 050
6039 060

- Co-Cr alloys
- Alliages Co-Cr
- Co-Cr Legierungen
- Aleaciones de cromo-cobalto
- Leghe Co-Cr

Cleaning stone

Silicone carbide

100 x 20 x7 mm

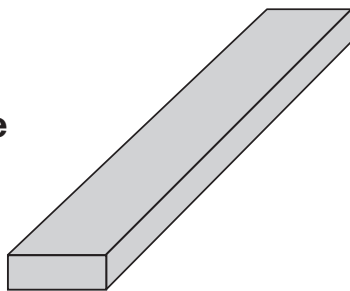

P	28
---	----

Order-No

1000

Sintered diamond discs

Disques diamantés frittés

Sinterdiamantscheiben

Discos de diamante macizos

Dischi diamantati sinterizzati



- Ceramics including zirconia
- Céramique y compris zircone
- Keramik einschließlich Zirkon
- Cerámica incluido zirconio
- Ceramica e zircone

5412 220 : Co-Cr

F
= 1

L /mm	0,15	0,20	0,30
Ø 1/10 mm	200	200	220
ISO shape	320	320	345
P	27	27	27

Order-No

5412F 200

5412 200

5412 220



- Co-Cr alloys
- Alliages Co-Cr
- Co-Cr Legierungen
- Aleaciones de cromo-cobalto
- Leghe Co-Cr

G
= 1

L /mm	0,45	3,0
Ø 1/10 mm	220	160
ISO shape	345	345
P	26	26

Order-No

5814 220

5808 160

Diamond discs and separating discs

Diaswiss's range of discs includes diamond discs for ceramics, plaster cutting discs, and separating discs for metals. Diamond discs feature multiple layering of natural diamonds, and offer convincing solutions for all applications, such as separating, contouring, and finishing ceramics or other materials. Different disc strengths and perforated designs enhance the product line. The high-quality manufacturing process ensures exceptionally smooth running and long life-time. In addition, Diaswiss offers a selection of plaster cutting discs with different diameters, also with multiple layers of natural diamonds and highly efficient cutting discs with a long operating time for separating metals.

Order-No

The order number is indicated as "Order-No." for each article, please use these order numbers plus the required diameter.

Packaging

Diaswiss diamond discs are mounted individually, or supplied in bulk unmounted. Plaster cutting discs are packed individually unmounted. Separating discs are supplied in packs of 20 unmounted.

Disques diamantés et disques à séparer

Le programme de disques de Diaswiss comprend des disques diamantés pour la céramique, des disques à tronçonner le plâtre ainsi que des disques à tronçonner les métaux. Les disques diamantés Diaswiss se distinguent par un revêtement multicouche composé de diamants naturels. Ils sont idéalement conçus pour des applications telles que la séparation d'éléments, le contourage et finition de la céramique ainsi que pour tout autres matériaux. Différentes épaisseurs de disques et schémas de perforation complètent l'assortiment, y compris pour des exigences élevées. Tous les disques diamantés Diaswiss offrent, grâce à la finition de qualité une longue durée de vie. Diaswiss propose aussi un choix de disques à tronçonner le plâtre en différents diamètres, qui sont également revêtus de plusieurs couches de diamants naturels. Pour le tronçonnage de métaux, Diaswiss propose des disques à tronçonner renforcés facilitant le travail de coupe et présentant une durée de vie élevée.

Référence

La référence est indiquée, pour chaque article, sous la forme «Order-No.», veuillez vous servir de ces références en indiquant le diamètre.

Conditionnement

Les disques diamantés Diaswiss sont conditionnés avec montage individuel ou en vrac non-montés. Les disques à tronçonner pour plâtre sont conditionnés individuellement non-montés. Les disques à tronçonner sont emballés par 20 pièces non-montés.

Recommended speed

- Diamond discs: 5,000 – 10,000 rpm
- Perforated diamond discs & UF diamond discs 3,000 – 5,000 rpm
- Plaster cutting discs: 5,000 – 10,000 rpm
- Separating discs: 5,000 – 20,000 rpm

Vitesses recommandées

- Disques diamantés: 5'000-10'000 tpm
- Disques diamantés perforés et disques diamantés UF 3'000-5'000 tpm
- Disques à tronçonner pour plâtre: 5'000-10'000 tpm
- Disques à tronçonner: 5'000-20'000 tpm

Diamantscheiben und Trennscheiben

Das Diaswiss Scheibenprogramm umfasst Diamantscheiben zur Keramikbearbeitung, Gipstrennscheiben sowie Trennscheiben für Metalle. Unsere Diamantscheiben zeichnen sich durch eine Mehrfachbeschichtung mit Naturdiamanten aus und bieten überzeugende Lösungen für alle Anwendungen wie Separieren, Konturieren und Beschleifen von Keramik oder anderen Materialien. Unterschiedliche Scheibenstärken und Perforationsmuster runden das Sortiment auch für anspruchsvolle Anforderungen ab. Alle Diaswiss Diamantscheiben zeichnen sich aufgrund der hochwertigen Verarbeitung durch besondere Standzeit und Laufruhe aus. Zusätzlich stellt Diaswiss eine Auswahl an Gipstrennscheiben in unterschiedlichen Durchmessern her, die ebenfalls mehrfach mit Naturdiamanten beschichtet sind. Zum Trennen von Metallen bietet Diaswiss speziell verstärkte, schneidfreudige Trennscheiben mit hoher Standzeit an.

Bestellnummer

Die Bestellnummer ist als „Order-No.“ bei jedem Artikel angegeben, bitte verwenden Sie diese Bestellnummern inkl. der Durchmesserangabe.

Verpackung

Diaswiss Diamantscheiben werden einzeln montiert oder alternativ unmontiert verpackt. Gipstrennscheiben werden einzeln unmontiert verpackt. Trennscheiben werden zu 20 Stück unmontiert verpackt.

Drehzahlempfehlung

- Diamantscheiben: 5' – 10.000 UpM
- Perforierte Diamantscheiben und Diamantscheiben UF: 3' – 5.000 UpM
- Gipstrennscheiben: 5' – 10.000 UpM
- Trennscheiben: 5' – 20.000 UpM

Discos de diamante y discos de separación

El programa de discos de Diaswiss incluye discos diamantados para el procesamiento de la cerámica, discos separadores para yeso y discos separadores para metales. Los discos diamantados de Diaswiss destacan por su revestimiento multicapa con diamantes naturales y ofrecen soluciones convincentes para todas las indicaciones, como la separación, el contorneado y el tallado de la cerámica y otros materiales. Los diferentes grosores de los discos y los diversos dibujos de perforación completan la gama para satisfacer también los requisitos más exigentes. Todos los discos diamantados de Diaswiss destacan por su durabilidad y suavidad de giro, posibles gracias a la extraordinaria calidad de su fabricación. Adicionalmente, Diaswiss ofrece una selección de discos separadores de yeso de diferentes diámetros que también están revestidos con varias capas de diamantes naturales. Para la separación de metales, Diaswiss ofrece discos separadores reforzados, con un gran rendimiento de corte y una elevada durabilidad.

Número de pedido

El número de pedido aparece indicado en todos los artículos como “Order-No.”. Por favor, utilice este número junto con la indicación del diámetro.

Envase

Los discos diamantados de Diaswiss son montados individualmente o suministrados sueltos sin mandril. Los discos separadores para yeso se envasan individualmente no montados. Los discos separadores se suministran en envases de 20 unidades no montados.

Velocidad recomendada

- Discos diamantados 5.000 – 10.000 rpm.
- Discos diamantados perforados y discos diamantados UF 3.000 – 5.000 rpm.
- Discos separadores para yeso: 5.000 – 10.000 rpm.
- Discos separadores: 5.000 – 20.000 rpm.

Dischi diamantati e dischi separatori

La gamma Diaswiss comprende dischi diamantati per la lavorazione delle ceramiche, dischi separatori per gesso e per metalli. I dischi diamantati Diaswiss si contraddistinguono per il loro rivestimento multistrato con diamanti naturali e offrono soluzioni convincenti per tutte le applicazioni, quali separazione, contornatura e limatura di ceramica o altri materiali. Completano l'assortimento diversi spessori di dischi e modelli di perforazione, anche per le esigenze più sofisticate. Tutti i dischi diamantati Diaswiss spiccano per la durata e la silenziosità che caratterizzano la lavorazione di alta qualità. Inoltre, Diaswiss offre una selezione di dischi separatori per gesso di diverso diametro, anch'essi rivestiti da più strati di diamante naturale. Per la separazione di metalli, Diaswiss offre dischi appositamente rinforzati e taglianti, dalla durata elevata.

Numero d'ordine

Il numero d'ordine è indicato su ogni articolo come "Order-No.". Utilizzare questi numeri di codice comprensivi dei dati relativi al diametro.

Confezione

I dischi diamantati Diaswiss sono confezionati montati singolarmente o in confezione smontata. I dischi separatori per gesso sono confezionati smontati singolarmente. I dischi separatori sono in confezioni da 20 smontati.

Numero di giri consigliato

- Dischi diamantati: 5' – 10.000 giri/min.
- Dischi diamantati perforati e dischi diamantati UF 3' – 5.000 giri/min.
- Dischi separatori per gesso: 5' – 10.000 giri/min.
- Dischi separatori: 5' – 20.000 giri/min.

ISO codification

The ISO codification consists of 15 digits in 5 groups:

Code ISO

Le code ISO est composé de 15 chiffres répartis en cinq groupes :

ISO-Nummernaufbau

Die ISO-Kodifizierung besteht aus 15 Ziffern, welche in 5 Teilblöcke eingeteilt sind:

Composición del número ISO

La codificación ISO se compone de 15 cifras, divididas en 5 bloques:

Struttura del numero ISO

La codifica ISO è costituita da 15 cifre, suddivise in 5 blocchi:

806

104

355

514

220

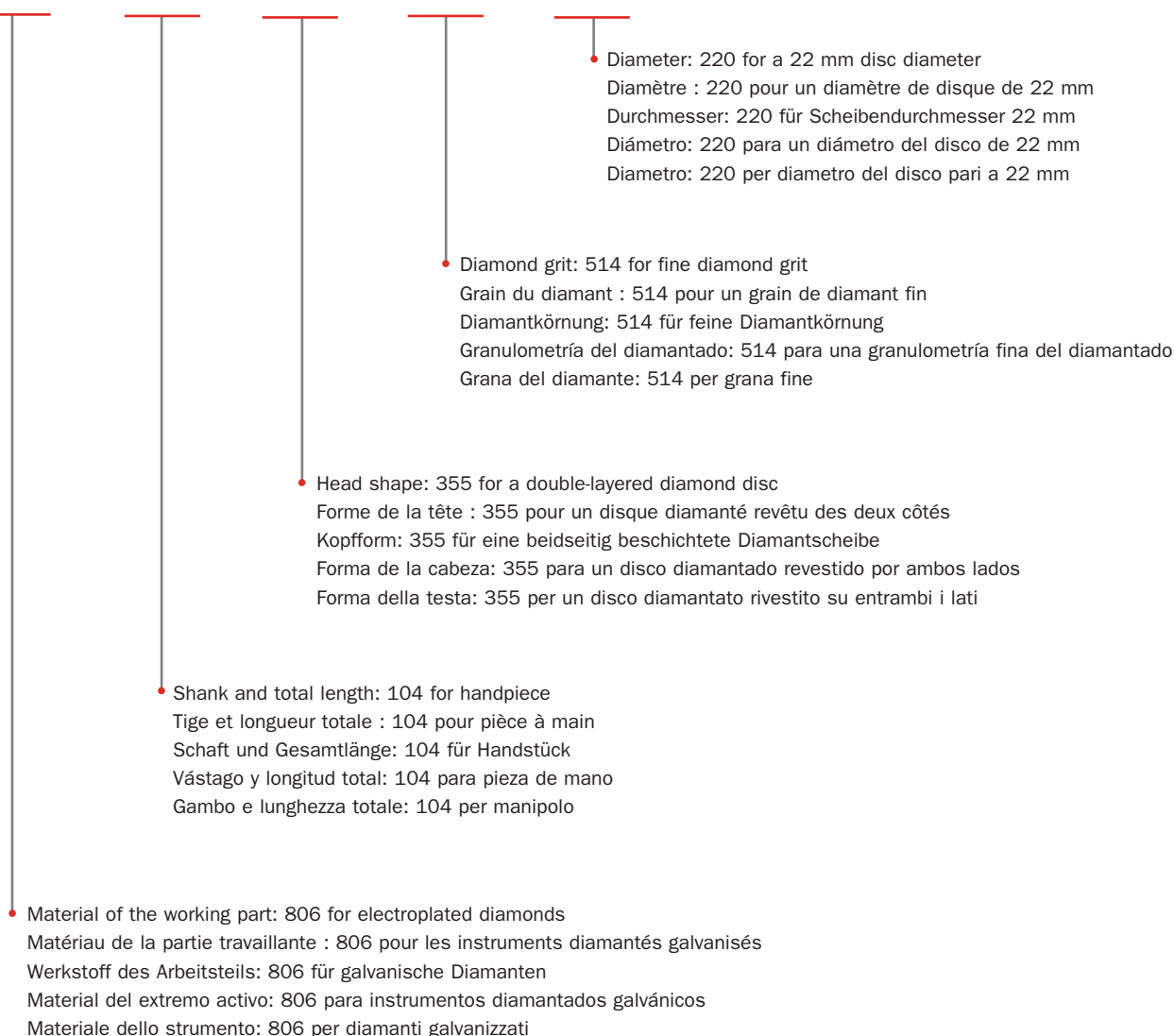

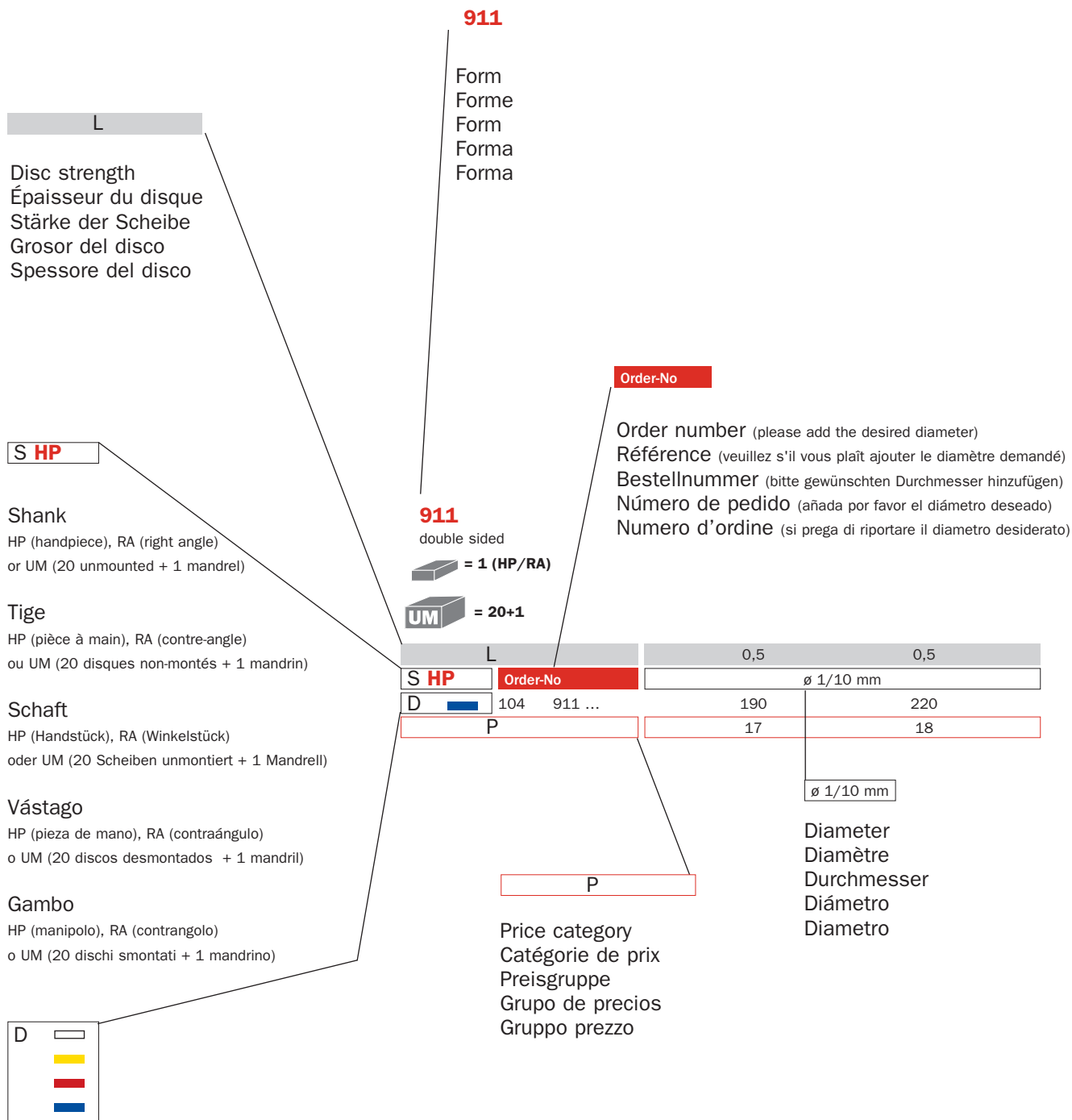

Diamond grit

White (UF): ultrafine ISO 494; Yellow (SF): superfine ISO 504; Red (F): fine ISO 514; Blue: medium (standard) ISO 524

Diamantage

Blanc (UF): ultrafin ISO 494; Jaune (SF): superfin ISO 504; Rouge (F): fin ISO 514; Bleu: moyen (standard) ISO 524

Diamantierung

Weiss (UF): ultrafein ISO 494; Gelb (SF): superfein ISO 504; Rot (F): fein ISO 514; Blau: mittel (standard) ISO 524

Diamantado

Blanco (UF): ultrafino ISO 494; Amarillo (SF): superfino ISO 504; Rojo (F): fino ISO 514; Azul: mediano (estándar) ISO 524

Rivestimento diamantato

Bianco (UF): ultrafine ISO 494; Giallo (SF): superfine ISO 504; Rosso (F): fine ISO 514; Blu: media (standard) ISO 524

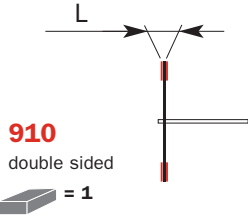
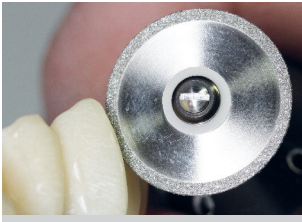

910
double sided
= 1



L		0,3	0,5	0,3	0,5
S HP	Order-No	ø 1/10 mm			
D	104 F 910 ...	160		220	
	104 910 ...		190		220
P		16	17	18	18

- Ceramics, composite
- Céramique, composites
- Keramik, Komposit
- Cerámica, resinas compuestas
- Ceramiche, composito

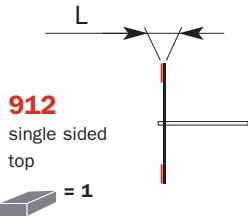

912
single sided
top
= 1



L		0,15	0,10	0,15	0,10
S HP	Order-No	ø 1/10 mm			
D	104 SF 912 ...		190		220
	104 F 912 ...	190		220	
P		18	18	18	18

- Ceramics, composite
- Céramique, composites
- Keramik, Komposit
- Cerámica, resinas compuestas
- Ceramiche, composito

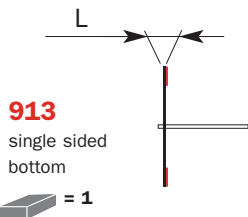
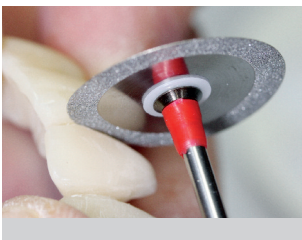

913
single sided
bottom
= 1



L		0,10	0,15	0,10
S HP	Order-No	ø 1/10 mm		
D	104 SF 913 ...	190		220
	104 F 913 ...		220	
P		18	18	18

- Ceramics, composite
- Céramique, composites
- Keramik, Komposit
- Cerámica, resinas compuestas
- Ceramiche, composito

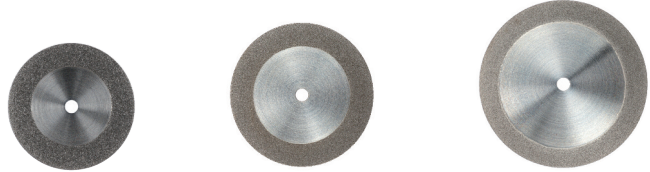
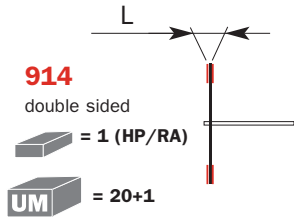
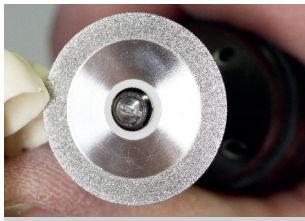

- Ceramics, composite
- Céramique, composites
- Keramik, Komposit
- Cerámica, resinas compuestas
- Ceramiche, composito

L		0,15	0,19	0,15	0,12	0,19	0,15	0,12
S HP	Order-No	ø 1/10 mm						
D	104 UF 914 ...				190			220
	104 SF 914 ...	160		190				220
	104 F 914 ...		190				220	
P		19	19	19	19	19	19	19
S UM	Order-No	ø 1/10 mm						
D	104 SF 914 ...	160-20		190-20				220-20
P		140		140				140

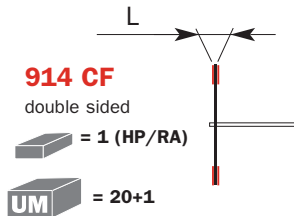
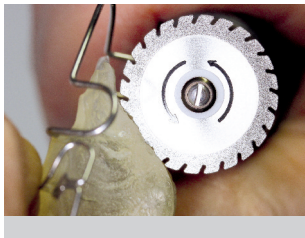

- Orthodontic resins, ceramics, composite
- Acryliques orthodontiques, céramique, composites
- KfO-Kunststoffe, Keramik, Komposit
- Resinas de ortodoncia, cerámica, resinas compuestas
- Resinas di ortodonzia, ceramiche, composito

L		0,17
S HP	Order-No	ø 1/10 mm
D	104 SF 914CF ...	220
P		19
S UM	Order-No	ø 1/10 mm
D	104 914CF ...	220-20
P		141

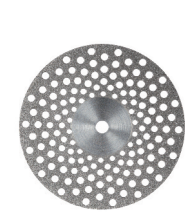
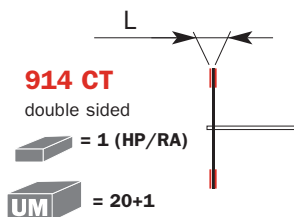
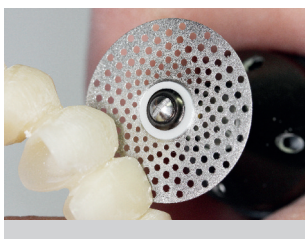

- Ceramics, composite
- Céramique, composites
- Keramik, Komposit
- Cerámica, resinas compuestas
- Ceramiche, composito

L		0,17
S HP	Order-No	ø 1/10 mm
D	104 SF 914CT ...	220
P		19
S UM	Order-No	ø 1/10 mm
D	104 914CT ...	220-20
P		141



- Ceramics, composite
- Céramique, composites
- Keramik, Komposit
- Cerámica, resinas compuestas
- Ceramiche, composito

914 SP
double sided

= 1 (HP/RA)

= 20+1

L		0,2
S HP	Order-No	∅ 1/10 mm
D	104 SF 914SP ...	220
P		19
S UM	Order-No	∅ 1/10 mm
D	104 914SP ...	220-20
P		141



- Ceramics, composite
- Céramique, composites
- Keramik, Komposit
- Cerámica, resinas compuestas
- Ceramiche, composito

916
single sided top

= 1

L		0,4
S HP	Order-No	∅ 1/10 mm
D	104 916 ...	220
P		19

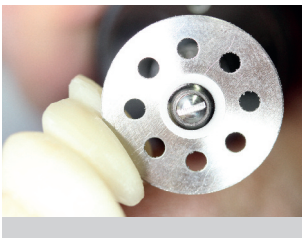

- Ceramics, composite
- Céramique, composites
- Keramik, Komposit
- Cerámica, resinas compuestas
- Ceramiche, composito

919
single sided bottom

= 1

L		0,4
S HP	Order-No	∅ 1/10 mm
D	104 919 ...	190
P		18

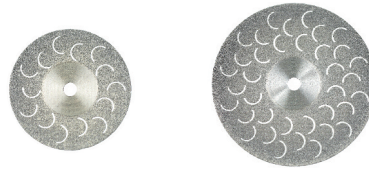
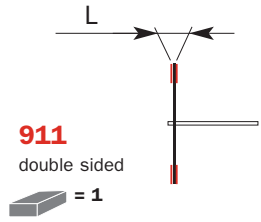

- Ceramics, composite
- Céramique, composites
- Keramik, Komposit
- Cerámica, resinas compuestas
- Ceramiche, composito

L		0,1	0,1
S HP	Order-No	ø 1/10 mm	
D	104 SF 911 ...	160	220
P		18	19

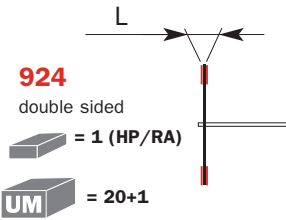
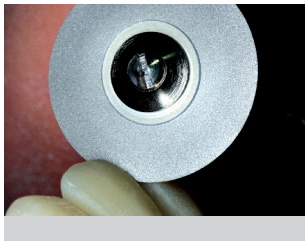

- Ceramics, composite
- Céramique, composites
- Keramik, Komposit
- Cerámica, resinas compuestas
- Ceramiche, composito

L		0,07	0,06
S HP	Order-No	ø 1/10 mm	
D	104 HF 924 ...	190	
	104 UF 924 ...		190
P		19	19
S UM	Order-No	ø 1/10 mm	
D	104 UF 924 ...		190-20
P			140

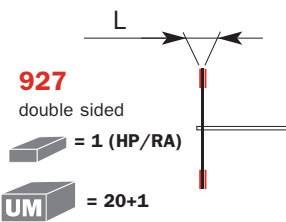

- Ceramics, composite
- Céramique, composites
- Keramik, Komposit
- Cerámica, resinas compuestas
- Ceramiche, composito

L		0,3	0,5
S HP	Order-No	ø 1/10 mm	
D	104 F 927 ...	220	
	104 927 ...		220
P		19	19
S UM	Order-No	ø 1/10 mm	
D	104 F 927 ...	220-20	
P		140	

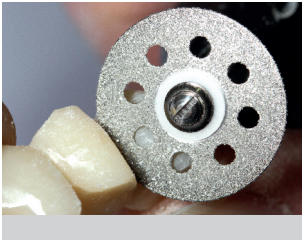

- Ceramics, composite
- Céramique, composites
- Keramik, Komposit
- Cerámica, resinas compuestas
- Ceramiche, composito

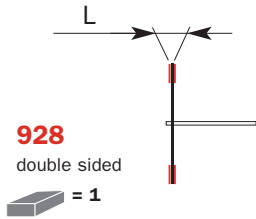

928
double sided
= 1

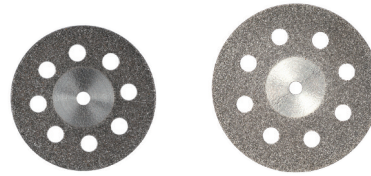

L		0,5	0,3
S HP	Order-No	ø 1/10 mm	
D	104 F 928 ...		220
	104 928 ...	190	
P		18	19

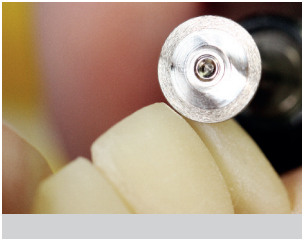

- Ceramics, composite
- Céramique, composites
- Keramik, Komposit
- Cerámica, resinas compuestas
- Ceramiche, composito

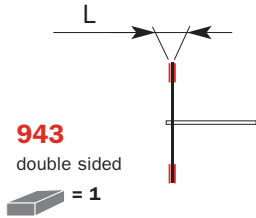

943
double sided
= 1



L		0,15	0,15
S HP	Order-No	ø 1/10 mm	
D	104 943 ...	065	080
P		20	20



- Ceramics, composite
- Céramique, composites
- Keramik, Komposit
- Cerámica, resinas compuestas
- Ceramiche, composito

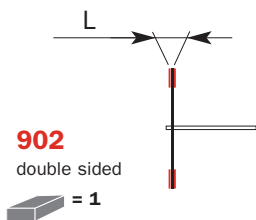

902
double sided
= 1



L		3
S HP	Order-No	ø 1/10 mm
D	104 902 ...	130
P		19

Plaster discs

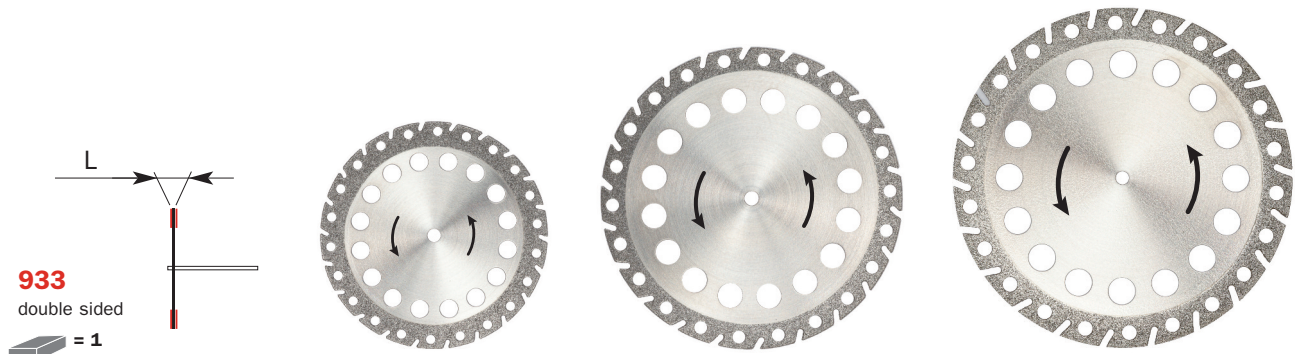

933
double sided
= 1

L	0,36	0,36	0,36
S HP	Order-No \varnothing 1/10 mm		
D	104 933 ...	300 400	450
P	118	119	119

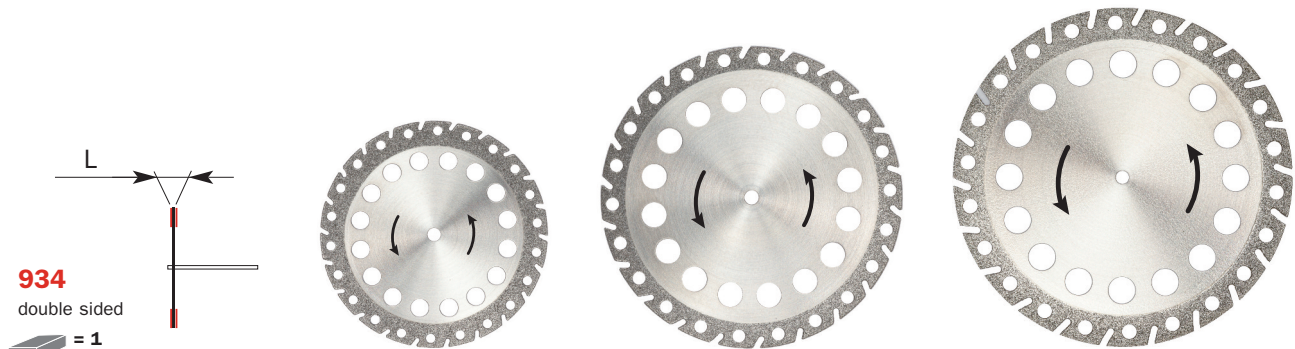

934
double sided
= 1

L	0,30	0,30	0,30
S HP	Order-No \varnothing 1/10 mm		
D	104 934 ...	300 400	450
P	118	119	119

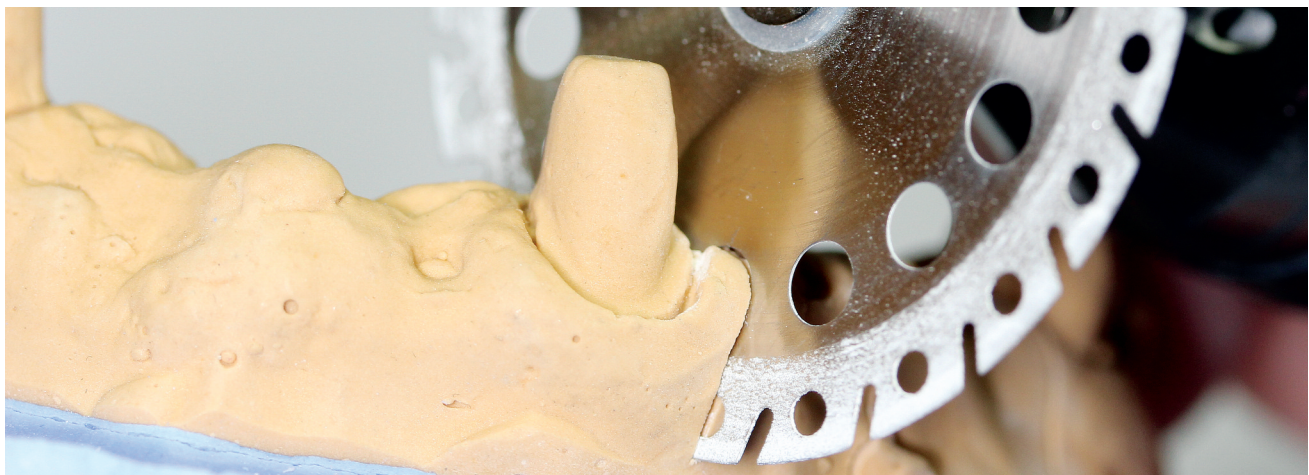

Separating discs

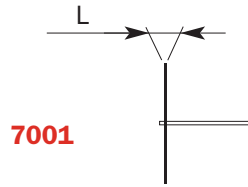

7001

= 20



L		0,3
S HP	Order-No	ø 1/10 mm
104	7001 ...	220
P		121

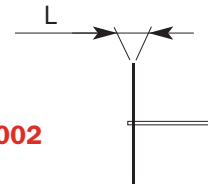

7002

= 20

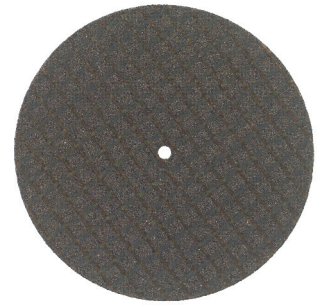

L		1,0
S HP	Order-No	ø 1/10 mm
104	7002 ...	400
P		122

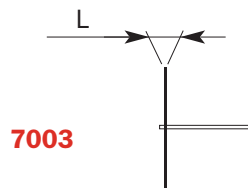

7003

= 20

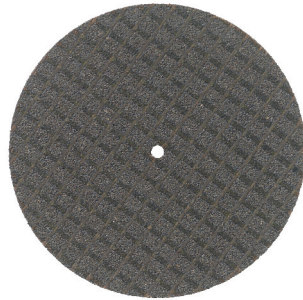

L		0,7
S HP	Order-No	ø 1/10 mm
104	7003 ...	400
P		122

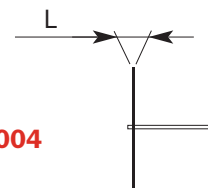

7004

= 20

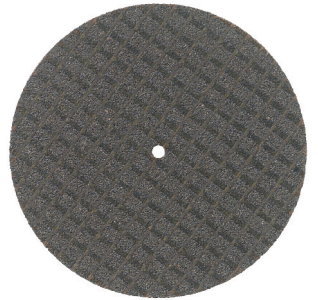

L		0,4
S HP	Order-No	ø 1/10 mm
104	7004 ...	400
P		122

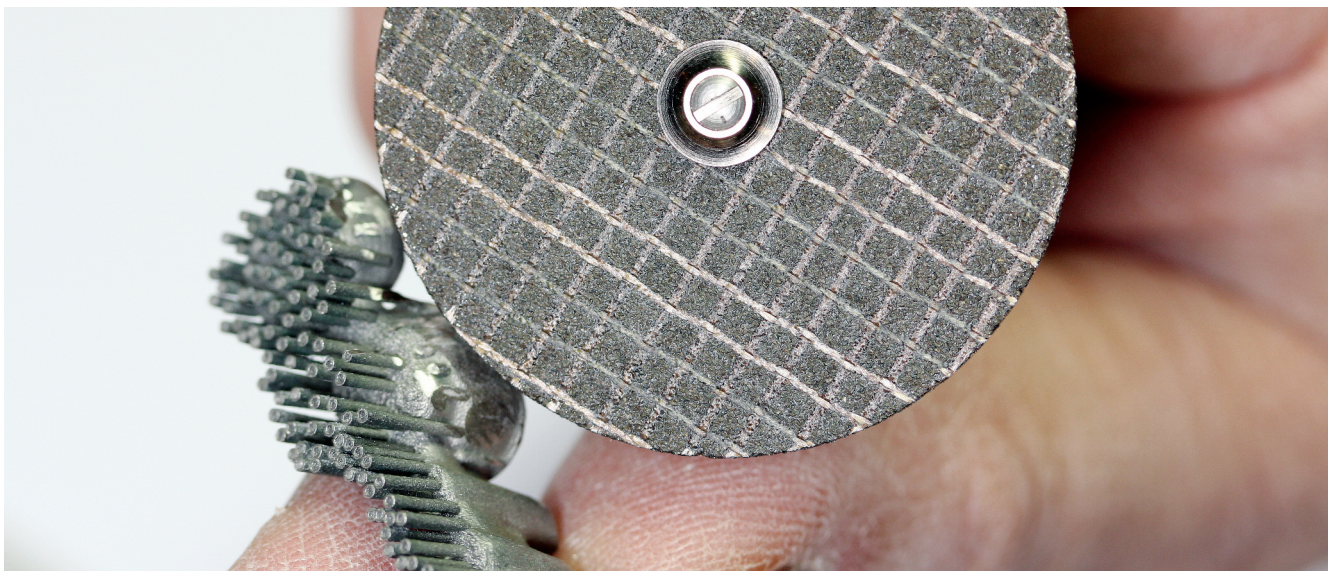

Zirconia tools

Diaswiss offers a range of innovative tools for working zirconia both for handpiece and for parallel milling using a hydro air carver. Diazircon tools allow easy and comfortable processing of zirconia, because for some of them there is no need for water cooling when handled correctly. The generation of heat is kept to a minimum by the porosity of the bond and because of the particular diamond grit. Along with coarse grit instruments for rapid trimming, we offer medium grit instruments (for abrasion and pre-polishing) and fine grit polishers. Furthermore, Diaswiss offers special zirconia diamonds for use in the hydro air carver in different angles or handpiece (water cooling required).

Order-No

The order number is indicated as "Order-No." for each article, please use these order numbers plus the required diameter.

Packaging

Diazircon tools are packed individually. Diamill zircon diamonds and HP diamonds are packed in sets of 6, or as 3 pcs (for refill orders).

Recommended speed

The recommended speed is specified for each instrument.

Instruments pour le zircon

Diaswiss propose un assortiment d'instruments pour travailler le zircon avec pièce à main ou par fraisage parallèle dans la turbine de laboratoire. Ces instruments permettent un travail performant des matériaux à base de zircon, pour certains un travail sans irrigation et possible dans la mesure ou les recommandations de vitesse et de technique sont respectées. Grâce à la porosité de la liaison ainsi qu'au type de grain diamanté, l'échauffement sera relativement faible. En plus des instruments à gros grains pour abrasion, Diaswiss met à votre disposition des instruments à grains moyens (pour abrasion et le prépolissage) ainsi que des polissoirs à grains fins. Diaswiss offre également des diamants spéciaux Diamill pour une utilisation avec la turbine de laboratoire à des angles différents et des diamants pour pièce à main (avec refroidissement à eau).

Référence

La référence est indiquée sur chaque article sous le terme «Order-No», veuillez utiliser ces numéros de commande et indiquer le diamètre.

Emballage

Les outils Diazircon sont emballés individuellement. Les diamants Diamill zircon et les diamants pièce à main sont emballés par 6 ou par 3 pièces (commande de réassortiment).

Vitesses recommandées

Les vitesses recommandées sont indiquées pour chaque instrument.

Zirkoninstrumente

Zur Bearbeitung von Zirkon bietet Diaswiss ein Sortiment innovativer Werkzeuge sowohl für das Handstück als auch zum Parallelfraßen in der Laborturbine an. Die Diazircon Werkzeuge ermöglichen ein angenehmes und produktives Bearbeiten von Zirkonmaterialien, da bei einigen Instrumenten durch richtige Handhabung auf Wasserkühlung verzichtet werden kann. Die Hitzeentwicklung wird aufgrund der Porosität der Bindung sowie der besonderen Diamantkörnung gering gehalten. Neben Instrumenten mit grober Körnung zum raschen Abtrag stehen Instrumente mittlerer Körnung (Abrasion und Vorpolitur) sowie Polierer mit feiner Körnung zur Verfügung. Darüber hinaus bietet Diaswiss spezielle Zirkondiamanten zur Verwendung in der Laborturbine bzw. im Handstück (mit Wasserkühlung) in verschiedenen Ausführungen an.

Bestellnummer

Die Bestellnummer ist als „Order-No.“ bei jedem Artikel angegeben, bitte verwenden Sie diese Bestellnummern inkl. der Durchmesserangabe.

Verpackung

Diazircon Werkzeuge werden einzeln verpackt. Diamill zircon Diamanten und galvanische Diamanten für das Handstück werden im Set zu 6 Stück oder zu 3 Stück (Nachbestellung) verpackt.

Drehzahlempfehlung

Die Drehzahlempfehlung ist bei jedem Instrument angegeben.

Instrumentos para zirconio

Para el procesamiento del zirconio, Diaswiss ofrece un surtido de innovadores instrumentos indicados tanto para el procesamiento del zirconio en la pieza de mano, como para el fresado paralelo en la turbina de laboratorio. Los instrumentos Diazircon permiten procesar de modo cómodo y productivo los materiales de zirconio porque, utilizados correctamente, unos de ellos hacen innecesario el uso de la refrigeración por agua. El calor generado se mantiene en unos niveles mínimos gracias a la porosidad del enlace y a la granulometría especial del diamantado. La gama incluye instrumentos de granulometría gruesa para la remoción rápida, instrumentos de granulometría media (abrasión y prepulido) y pulidores de granulometría fina. Además, Diaswiss ofrece diferentes modelos de fresas diamantadas de zirconio especiales para su uso en la turbina de laboratorio o en la pieza de mano (con refrigeración por agua).

Número de pedido

El número de pedido aparece indicado en todos los artículos como "Order-No.". Por favor, utilice este número junto con la indicación del diámetro.

Envase

Los instrumentos Diazircon se suministran en envases individuales. Las fresas diamantadas Diamill zircon y las fresas diamantadas PM están disponibles en 6 unidades o en envases de 3 unidades (pedido posterior).

Velocidad recomendada

En cada instrumento se indica la velocidad recomendada.

Strumenti per zirconia

Per la lavorazione della zirconia Diaswiss offre un assortimento di strumenti innovativi sia per la lavorazione con il manipo che per il fresaggio parallelo con la turbina da laboratorio. Gli strumenti Diazircon permettono di lavorare l'ossido di zirconio in modo comodo e produttivo, perché con la giusta applicazione con alcuni strumenti si può rinunciare al raffreddamento ad acqua. Il calore che si sviluppa rimane limitato grazie alla porosità del legante e alla particolare grana diamantata. Oltre agli strumenti a grana grossa per una rapida asportazione del materiale sono disponibili strumenti a grana media (abrasione e prelucidatura) nonché strumenti abrasivi a grana fine per la lucidatura. Diaswiss offre inoltre diversi modelli di frese diamantate speciali per zirconia da impiegare nella turbina da laboratorio o manipo (con raffreddamento ad acqua).

Numero d'ordine

Il numero d'ordine è riportato come "Order-No." per ogni articolo. Si prega di usare questo codice di ordinazione compresi i dati del diametro.

Confezione

Gli strumenti Diazircon sono confezionati singolarmente. Le frese diamantate Diamill zircon e le frese diamantate H.P. sono vendute come set (6 pezzi) o in confezione da 3 pezzi (riordino).

Numero di giri consigliato

Il numero di giri consigliato è indicato per ogni strumento.

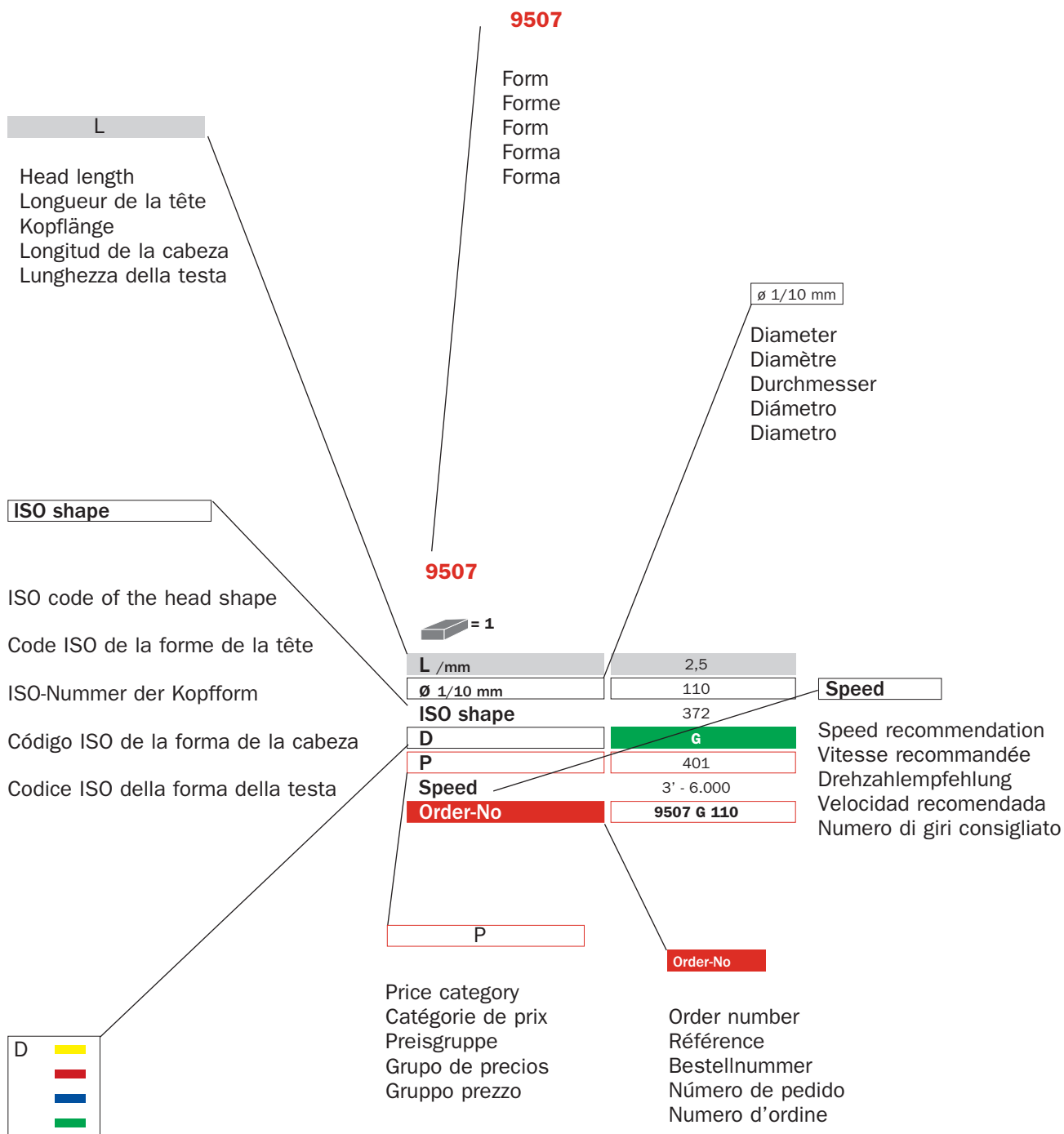

Diamond grit

Yellow (C): superfine ISO 504; Red (F): fine ISO 514; Blue: medium (Standard) ISO 524; Green (G): coarse ISO 534

Diamantage

Jaune (C): superfine ISO 504; Rouge (F): fin ISO 514; Bleu: moyen (standard) ISO 524; Vert (G): gros ISO 534

Diamantkörnung

Gelb (C): superfine ISO 504; Rot (F): fein ISO 514; Blau: mittel (Standard) ISO 524; Grün (G): grob ISO 534

Diamantado

Amarillo (C): superfino ISO 504; Rojo (F): fino ISO 514; Azul: mediano (estándar) ISO 524; Verde (G): grueso ISO 534

Diamantatura

Giallo (C): superfine ISO 504; Rosso (F): fine ISO 514; Blu: media (standard) ISO 524; Verde (G): grossa ISO 534

Diazircon coarse

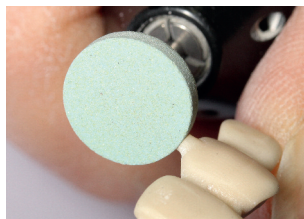

9848



L /mm	11,0
Ø 1/10 mm	040
ISO shape	173
D	G
P	400
Speed	3' - 18.000
Order-No	9848 G 040



9507



L /mm	2,5
Ø 1/10 mm	110
ISO shape	372
D	G
P	401
Speed	3' - 5.000
Order-No	9507 G 110

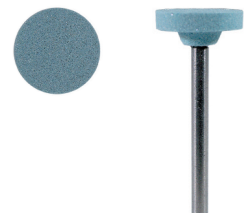

Diazircon medium



9848



L /mm	10,5
Ø 1/10 mm	035
ISO shape	173
D	
P	402
Speed	3' - 15.000
Order-No	9848 035



9502



L /mm	11,0
Ø 1/10 mm	060
ISO shape	250
D	
P	402
Speed	3' - 15.000
Order-No	9502 060



9777



L /mm	1,3
Ø 1/10 mm	170
ISO shape	371
D	
P	403
Speed	3' - 8.000
Order-No	9777 170

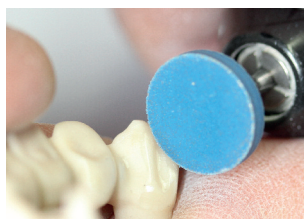

9507



L /mm	2,5
Ø 1/10 mm	110
ISO shape	372
D	
P	402
Speed	3' - 5.000
Order-No	9507 110



Diazircon polish



9507



L /mm	15,5
Ø 1/10 mm	050
ISO shape	292
D	c
P	404
Speed	3' - 5.000
Order-No	9507 C 050



9500



L /mm	2,5
Ø 1/10 mm	150
ISO shape	372
D	c
P	404
Speed	3' - 10.000
Order-No	9500 C 150



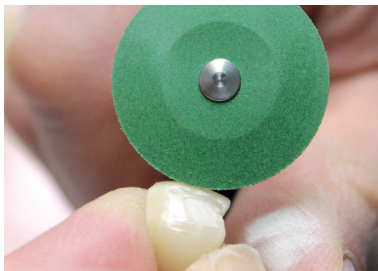

Poli-Max I
S: HP

Speed: - 10.000



L	2,2	2,7
D ø 1/10 mm	260	150
Order-No	800HP	801HP
ISO shape	303	372
P	405	402
VE 	1	1
Step	1	1

- Corrective shaping of sintered zirconia, strong abrasive effect
- Travaux de correction et de façonnement du zircone fritté, fort effet abrasif
- Formgebende Korrekturen von gesinterem Zirkon, hohe Abtragsleistung
- Correcciones moldeadoras de zirconio sinterizado, fuerte efecto abrasivo
- Lavori di correzione delle forme dello zirconio sinterizzato, forte effetto abrasivo

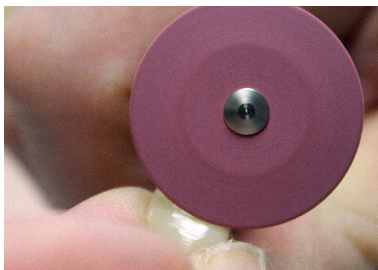

Poli-Max II
S: HP

Speed: - 10.000



L	2,2	3,0
D ø 1/10 mm	260	170
Order-No	810HP	811HP
ISO shape	303	372
P	405	409
VE 	1	1
Step	2	2

- Corrective shaping of sintered zirconia, medium abrasive effect
- Travaux de correction et de façonnement du zircone fritté, effet abrasif
- Formgebende Korrekturen von gesinterem Zirkon, mittlere Abtragsleistung
- Correcciones moldeadoras de zirconio sinterizado, efecto abrasivo mediano
- Lavori di correzione delle forme dello zirconio sinterizzato, effetto abrasivo

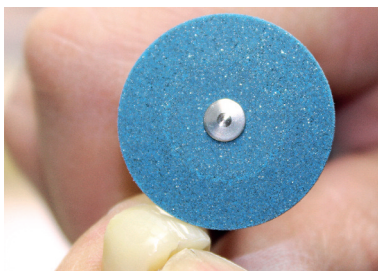

Poli-Max III
S: HP

Speed: - 10.000



L	2,2	3,0
D ø 1/10 mm	260	170
Order-No	820HP	821HP
ISO shape	303	372
P	405	409
VE 	1	1
Step	3	3

- Prepolisher for sintered zirconia, shaping of lithium disilicate
- Prépolissoir pour travaux sur zircone fritté, façonnement du disilicate de lithium
- Vorpolierer für gesintertes Zirkon, Formgebung für Lithiumdisilikat
- Prepulidor para zirconio sinterizado, moldeo de disilicato de litio
- Per la prima fase die lucidatura dello zirconio sinterizzato, formatura del litio disilicat

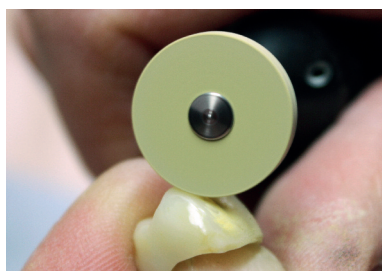

**Poli-Max
Supergloss
S: HP**

Speed: - 10.000

- High shine polisher for sintered zirconia and lithium disilicat
- Polissoir haute brillance pour le zircone fritté et le disilicate de lithium
- Glanzpolierer für gesintertes Zirkon und Lithiumdisilikat
- Pulidor de brillo para zirconio sinterizado y disilicato de litio
- Per la lucidatura alto brillo dello zirconio sinterizzato et del litio disilicat



L	2,2	3,0	16
D ø 1/10 mm	260	170	055
Order-No	830HP	831HP	832HP
ISO shape	303	372	243
P	405	409	404
VE	1	1	1

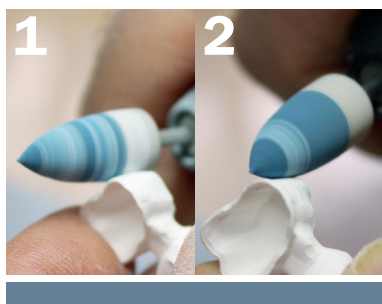

**Poli-Max
2-Phase
S: HP**

Speed: 5 - 10.000

- 2 in 1 polisher for sintered zirconia. White part for abrasion and shaping, blue part for final adjustments
- Polissoir en 2 phases pour le zircone fritté. Partie blanche pour forte abrasion, partie bleue pour ajustements finaux
- 2-Phasen Polierer zur Bearbeitung von Zirkon im gesintertem Stadium. Weiß: grobe Reduktion, blau: finale Adjustierung
- Pulidor de 2 fases para trabajar zirconio sinterizado. Parte blanca para fuerte efecto abrasivo, parte azul para ajuste final
- Gommino in 2 fasi per lavorare lo zirconio sinterizzato. Parte bianca per forte effetto abrasivo, parte azzurra per aggiustamento finale



L	21,5
D ø 1/10 mm	100
Order-No	850HP
ISO shape	243
P	405
VE	1

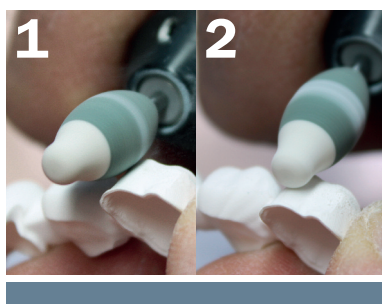

**Poli-Max
2-Phase fine
S: HP**

Speed: 5 - 10.000

- 2 in 1 polisher for green-state zirconia. Grey part for shaping, white part for final adjustments
- Polissoir en 2 phases pour le zircone non fritté. Partie grise pour abrasion, partie blanche pour ajustements finaux
- 2-Phasen Polierer zur Bearbeitung von Zirkon im Kreidestadium. Grau: Reduktion, weiss: finale Adjustierung
- Pulidor de 2 fases para trabajar zirconio no sinterizado. Parte gris para efecto abrasivo, parte blanca para ajuste final
- Gommino in 2 fasi per lavorare lo zirconio non sinterizzato. Parte grigia per effetto abrasivo, parte bianca per aggiustamento finale



L	22,7
D ø 1/10 mm	100
Order-No	840HP
ISO shape	507
P	404
VE	1



NEW

CC3

= 1

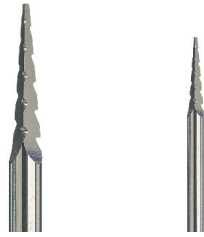

L /mm	10,5
Ø 1/10 mm	023
ISO shape	468
P	41
Speed	25' - 30.000
Order-No	1CC3.023Zir

- Cutting of connecting bars in green state zirconia
- Coupe des barres de liaison du zircon non-fritté
- Trennen der Verbindungsstege von Zirkon im Kreidestadium
- Separación de los puentes de conexión en estado no sinterizado
- Per separare i canali dopo la fresatura (CAD/CAM), di zirconio in stato gessoso

Diazircon Kit
for zirconia and IPS e.max®
P: 407
S: **HP**



Ø	110	035	060	110	050	150
D	G	C	C	C	C	C
P	401	402	402	402	404	404
Order-No	9507 G 110	9848 035	9502 060	9507 110	9507 C 050	9500 C 150

IPS e.max® ist eine eingetragene Marke der Firma Ivoclar Vivadent.
IPS e.max® is registered trademark of Ivoclar Vivadent.

HP diamonds for zirconia

Diamants PM pour zircon

HST Diamanten für Zirkon

Fresas diamantadas PM para zirconio

Frese diamantata H.P. per zirconio

830L
ISO 239



= 6

L	5,0
S HP	Order-No
D	104 830L ...
P	14

847
ISO 172



= 6

L	8,0
S HP	Order-No
D	104 Z 847 ...
P	13

- Specially designed gold-plated diamonds
- Highly effective on zirconia
- Excellent lifetime
- Speed: 25' - 30.000 rpm
- **Water cooling required**

850
ISO 199



= 6

L	10,0
S HP	Order-No
D	104 Z 850 ...
P	14

862
ISO 249



= 6

L	8,0
S HP	Order-No
D	104 Z 862 ...
P	13

- Revêtement doré en diamant spécial
- Abrasion efficace
- Longue durée de vie
- Vitesse: 25' - 30.000 tpm
- **Refroidissement à eau**

- Spezialdiamantierung mit Goldbeschichtung
- Effizienter Abtrag
- Hohe Standzeit
- Drehzahl: 25' - 30.000 Upm
- **Wasserkühlung**

- Diamantado especial dorado para zirconio
- Importante fuerza de abrasión
- Excelente vida útil
- Velocidad: 25' - 30.000 rpm
- **Refrigeración por agua**

881
ISO 141



= 6

L	9,0
S HP	Order-No
D	104 Z 881 ...
P	13

- Diamantatura speciale dorata
- Sgrossatura veloce e efficiente
- Di lunga durata
- Giri: 25' - 30.000 rpm
- **Raffreddamento ad acqua**

Water cooling required | Refroidissement à eau | Wasserkühlung | Refrigeración por agua | Raffredamento ad acqua

Diamill zircon 0°



P	405
Speed	- 300.000
Order-No	DMZ Set 0

L /mm	10,5	10,5	10,5	10,5	10,5
Ø 1/10 mm	018	018	018	018	018
ISO shape	142	142	142	142	142
P	406	406	406	406	406
Speed	- 300.000	- 300.000	- 300.000	- 300.000	- 300.000
Order-No	01 DMZ 0	02 DMZ 0	03 DMZ 0	04 DMZ 0	05 DMZ 0

Diamill zircon 1°



P	405
Speed	- 300.000
Order-No	DMZ Set 1

L /mm	10,0	10,0	10,0	10,0	10,0
Ø 1/10 mm	023	023	023	023	023
ISO shape	199	199	199	199	199
P	406	406	406	406	406
Speed	- 300.000	- 300.000	- 300.000	- 300.000	- 300.000
Order-No	01 DMZ 1	02 DMZ 1	03 DMZ 1	04 DMZ 1	05 DMZ 1

Diamill zircon 2°



P	405
Speed	- 300.000
Order-No	DMZ Set 2

L /mm	10,0	10,0	10,0	10,0	10,0
Ø 1/10 mm	023	023	023	023	023
ISO shape	199	199	199	199	199
P	406	406	406	406	406
Speed	- 300.000	- 300.000	- 300.000	- 300.000	- 300.000
Order-No	01 DMZ 2	02 DMZ 2	03 DMZ 2	04 DMZ 2	05 DMZ 2

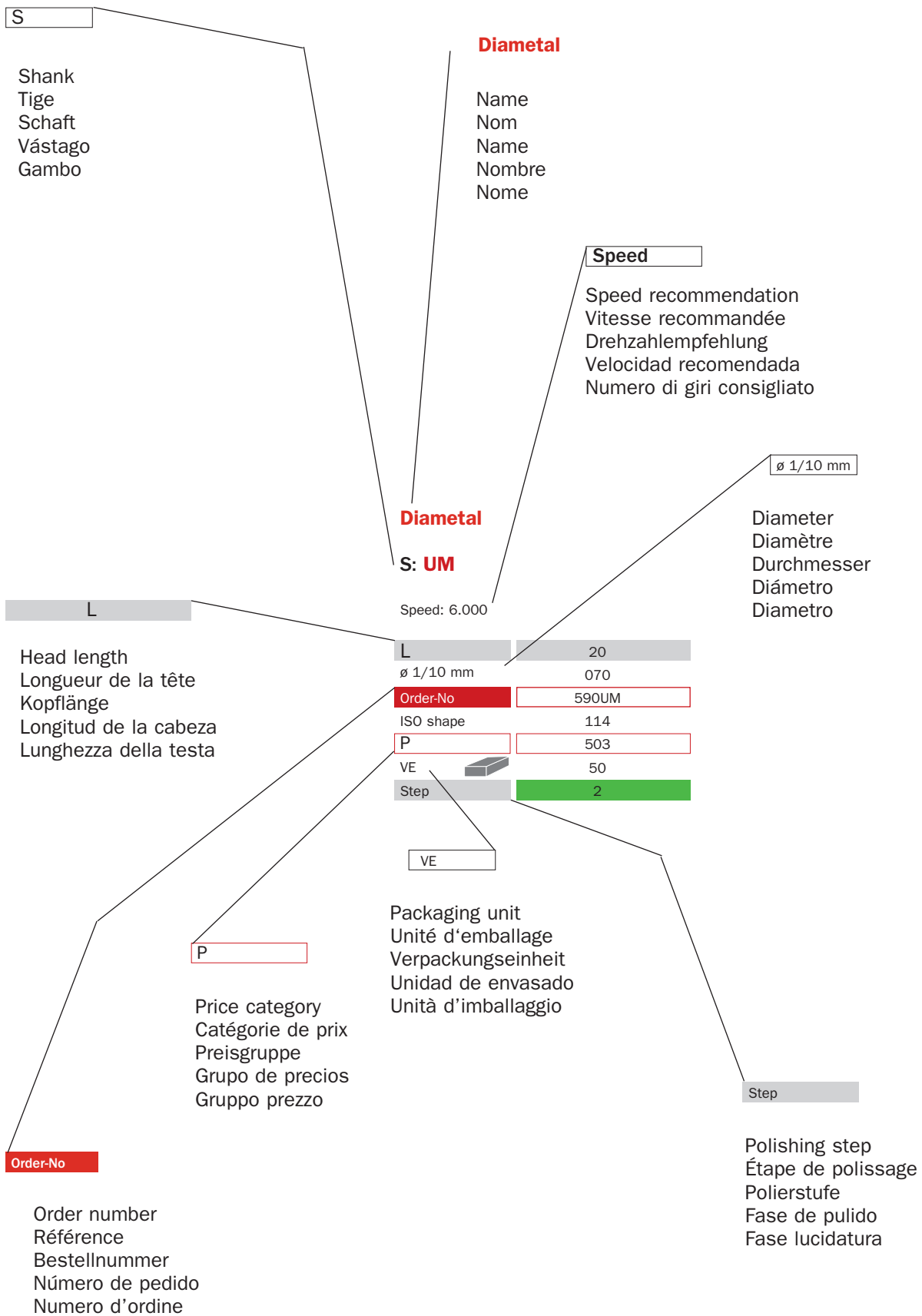

Diaceram 2-step

Polishing system for ceramics in 2 steps. Diamond-impregnated polishers for polishing, finishing and high-shine.

Diaceram 2-step

Sistema de pulido de dos fases para todas las cerámicas habituales. Pulidores diamantados para el pulido, el acabado y el pulido de alto brillo.

Diaceram 2-step

Système de polissage en deux étapes pour toutes les céramiques courantes. Polissoirs diamantés pour le polissage, la finition et le polissage brillant.

Diaceram 2-step

Sistema di lucidatura a due fasi per tutte le ceramiche in commercio. Gommini diamantati per lucidatura, finitura e brillantatura.

Diaceram 2-step

Zweistufiges Poliersystem für alle gängigen Keramiken. Diamantierte Polierer zum Polieren, Finieren und Hochglanzpolieren.

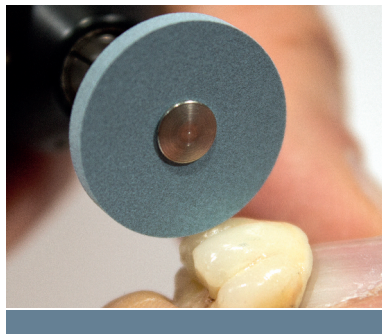

Diaceram 2-step
S: HP

Speed: 6.000



L	2	2,4	18
D ø 1/10 mm	260	180	055
Order-No	500HP	501HP	502HP
ISO shape	303	372	243
P	500	501	502
VE 	1	1	1
Step	1	1	1

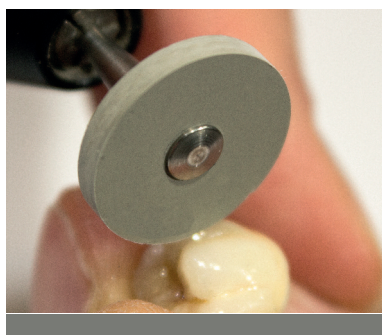

Diaceram 2-step
S: HP

Speed: 6.000



L	2	2,4	18
D ø 1/10 mm	260	180	055
Order-No	510HP	511HP	512HP
ISO shape	303	372	243
P	500	501	502
VE 	1	1	1
Step	2	2	2

Diaceram 3-step

Polishing system for ceramics including zirconia in 3 steps. Diamond-impregnated polishers for abrasion (step 1), polishing and smoothing of surfaces (step 2) and high-shine (step 3).

Diaceram 3-step

Système de polissage en trois étapes pour toutes les céramiques courantes, y compris le zircon. Polissoirs diamantés pour abrasion (étape 1), le polissage et le lissage de la surface (étape 2) et le polissage brillant (étape 3).

Diaceram 3-step

Dreistufiges Poliersystem für alle gängigen Keramiken einschließlich Zirkon. Diamantierte Polierer für Materialabtrag (Stufe 1), Polieren und Oberflächenglättung (Stufe 2) und Hochglanzpolitur (Stufe 3).

Diaceram 3-step

Sistema de pulido de tres fases para todas las cerámicas habituales, incluido el zirconio. Pulidores diamantados para la remoción del material (fase 1), el pulido y el alisado de las superficies (fase 2) y el pulido de alto brillo (fase 3).

Diaceram 3-step

Sistema di lucidatura a tre fasi per tutte le ceramiche in commercio, zirconia compresa. Gomini diamantati per sgrossatura (fase 1), lucidatura e levigatura delle superfici (fase 2) e brillantatura (fase 3).

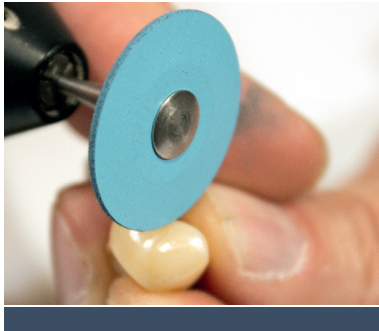

Diaceram 3-step S: HP

Speed: 6.000

L	2	2,4	13
D ø 1/10 mm	260	180	045
Order-No	550HP	551HP	552HP
ISO shape	303	372	243
P	500	501	502
VE 	1	1	1
Step	1	1	1



Diaceram 3-step S: HP

Speed: 6.000

L	2	2,4	13
D ø 1/10 mm	260	180	045
Order-No	560HP	561HP	562HP
ISO shape	303	372	243
P	500	501	502
VE 	1	1	1
Step	2	2	2



Diaceram 3-step S: HP

Speed: 6.000

L	2	2,4	13
D ø 1/10 mm	260	180	045
Order-No	570HP	571HP	572HP
ISO shape	303	372	243
P	500	501	502
VE 	1	1	1
Step	3	3	3



Diametal

Polishing system for partials in 2 steps. Polyurethane polishers with silicone carbide.

Diametal

Sistema de pulido de dos fases para esqueléticos. Pulidores de poliuretano altamente resistente con carburo de silicio.

Diametal

Système de polissage en deux étapes pour la coulée des modèles. Polissoirs en polyuréthane hautement résistant avec carbure de silicium.

Diametal

Sistema di lucidatura a due fasi per scheletrati. Gommini in poliuretano ad alta resistenza con carburo di silicio.

Diametal

Zweistufiges Poliersystem für Modellguss. Polierer aus hochbeständigem Polyurethan mit Siliziumkarbid.



Diametal

S: UM

Speed: 6.000

L	20	3	3,5
D ø 1/10 mm	070	220	220
Order-No	580UM	581UM	582UM
ISO shape	114	372	303
P	503	504	504
VE 	50	12	12
Step	1	1	1

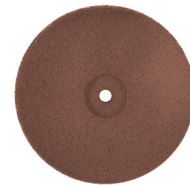
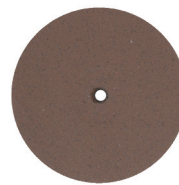

Diametal

S: UM

Speed: 6.000

L	20	3	3,5
D ø 1/10 mm	070	220	220
Order-No	590UM	591UM	592UM
ISO shape	114	372	303
P	503	504	504
VE 	50	12	12
Step	2	2	2



Diacrown

Polishing system for non-precious crowns and bridges in 2 steps. Polyurethane polishers impregnated with diamonds and silicone carbide.

Diacrown

Système de polissage en deux étapes pour les couronnes et les ponts en alliages non-précieux. Polissoirs en polyuréthane hautement résistant avec carbure de silicium et diamant.

Diacrown

Zweistufiges Poliersystem für Kronen und Brücken aus NE-Metall. Diamantpolierer aus hochbeständigem Polyurethan mit Siliziumkarbid und Diamant.

Diacrown

Sistema de pulido de dos fases para coronas y puentes de aleaciones no preciosas. Pulidores diamantados de poliuretano altamente resistente con carburo de silicio y diamante.

Diacrown

Sistema di lucidatura a due fasi per ponti e corone in metallo non prezioso. Gommmini diamantati in poliuretano ad alta resistenza con carburo di silicio e diamante.



Diacrown

S: **HP**

Speed: 6.000

L	3,5	3	18
D ø 1/10 mm	220	220	055
Order-No	600HP	601HP	602HP
ISO shape	303	372	243
P	502	502	505
VE 	1	1	3
Step	1	1	1



Diacrown

S: **HP**

Speed: 6.000

L	3,5	3	18
D ø 1/10 mm	220	220	055
Order-No	610HP	611HP	612HP
ISO shape	303	372	243
P	502	502	505
VE 	1	1	3
Step	2	2	2



Diacryl Pol

Silicone-based polishing system in 2 steps for acrylics.

Diacryl Pol

Sistema de pulido de silicona de dos fases para resinas para prótesis.

Diacryl Pol

Système de polissage en silicone en deux étapes pour la résine prothétique.

Diacryl Pol

Gommini per la lucidatura di protesi in resina.

Diacryl Pol

Zweistufiges Silikonpoliersystem für Prothesenkunststoff.



Diacryl Pol

S: UM

Speed: 6.000

L	22	23,5	20
D ø 1/10 mm	120	100	080
Order-No	640UM	641UM	642UM
ISO shape	257	275	273
P	501	503	503
VE 	12 + 1 mandrel	12 + 1 mandrel	12 + 1 mandrel
Step	1	1	1



Diacryl Pol

S: UM

Speed: 6.000

L	22	23,5	20
D ø 1/10 mm	120	100	080
Order-No	650UM	651UM	652UM
ISO shape	257	275	273
P	501	503	503
VE 	12 + 1 mandrel	12 + 1 mandrel	12 + 1 mandrel
Step	2	2	2



Diatitan

Polishing system for titanium in 3 steps. Diamond-impregnated polishers with diamond and silicone carbide.

Diatitan

Système de polissage en trois étapes pour le titane. Polissoirs diamantés en polyuréthane hautement résistant avec carbure de silicium et diamant.

Diatitan

Dreistufiges Poliersystem für Titan. Diamantierte Polierer aus hochbeständigen Polyurethan mit Diamanten und Siliziumkarbid.

Diatitan

Sistema de pulido de tres fases para titanio. Pulidores diamantados de poliuretano altamente resistente con diamante y carburo de silicio.

Diatitan

Sistema di lucidatura a tre fasi per il titanio. Gommini diamantati in poliuretano ad alta resistenza con diamante e carburo di silicio.

Diatitan

S: HP

Speed: 6.000

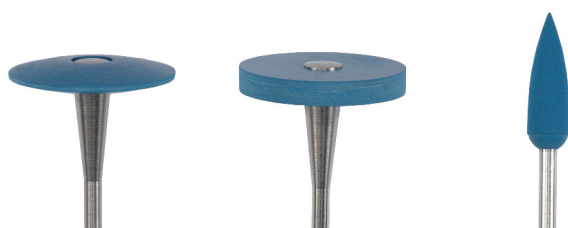

L	3,5	3	18
D \varnothing 1/10 mm	220	220	055
Order-No	670HP	671HP	672HP
ISO shape	303	372	243
P	501	501	504
VE 	1	1	1
Step	1	1	1

Diatitan

S: HP

Speed: 6.000



L	3,5	3	18
D \varnothing 1/10 mm	220	220	055
Order-No	680HP	681HP	682HP
ISO shape	303	372	243
P	501	501	504
VE 	1	1	1
Step	2	2	2

Diatitan

S: HP

Speed: 6.000



L	3,5	3	18
D \varnothing 1/10 mm	220	220	055
Order-No	690HP	691HP	692HP
ISO shape	303	372	243
P	501	501	504
VE 	1	1	1
Step	3	3	3

Note: see dentistry section for polishers for provisionals.

N.B. : pour les polissoirs pour prothèses provisoires, voir la section cabinet.

Hinweis: siehe Zahnarztteil betreffend Polierer für Provisorien.

Nota: consulte los pulidores para provisionales en la sección clínica dental.

Nota: Vedere la parte studio per gli strumenti di lucidatura per provvisori.

Diabrush

Polishing brushes for metals (steps 0 to 2), ceramics (steps 3 to 4) and composites/acrylics (steps 4 to 5). The texture of the brush allows easy polishing of all surfaces including occlusal and interdental surfaces. Please note: intermittent pressure and circular polishing movements.

Diabrush

Brosses de polissage pour métaux (degrés 0 à 2) ainsi que pour la céramique (degrés 3 à 4) et composites/résines (degrés 4 à 5). La structure des brosses permet un polissage facile des surfaces occlusales et des espaces interdentaires. Attention : pression intermittente et mouvements de polissage concentriques.

Diabrush

Polierbürsten für Metall (Stufe 0 bis 2) sowie für Keramik (Stufe 3 bis 4) und Komposit/Kunststoff (Stufe 4 bis 5). Die Bürstenstruktur erlaubt ein problemloses Polieren auch von Okklusalfächen und Interdentalräumen. Bitte beachten: intermittierender Druck und kreisende Polierbewegungen.

Diabrush

Cepillos para pulir metal (paso 0 a 2), cerámica (paso 3 a 4) y resinas compuestas/acrílicos protéticos (paso 4 a 5). La estructura de los cepillos permite pulir fácilmente incluso las superficies oclusales y los espacios interdentales. Observación: ejercer siempre una presión intermitente y pulir realizando movimientos circulares.

Diabrush

Spazzole da lucidatura per metallo (da 0 a 2), per ceramica (da 3 a 4) e per composito/resina (da 4 a 5). La struttura della spazzola permette di lucidare senza problemi anche le superfici occlusali e gli spazi interprossimali. Attenzione: lucidare esercitando pressione intermittente e con movimenti rotatori.





Diabrush

S: HP

Speed: 3'-5.000

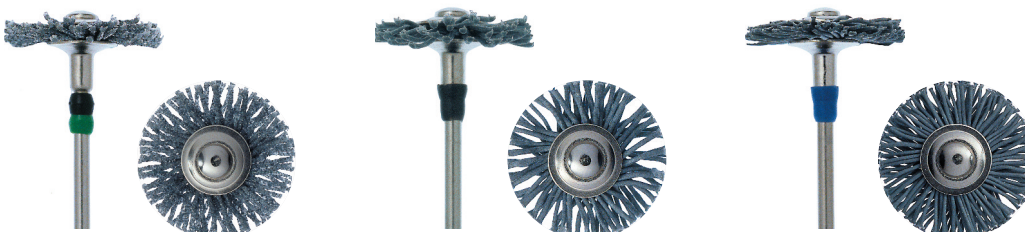
D ø 1/10 mm



	210	210	210
Order-No	700HP	701HP	702HP
ISO shape	543	543	543
P	506	506	506
VE 	5	5	5
Step	0	1	2

Diabrush

S: HP

Speed: 3'-5.000

D ø 1/10 mm

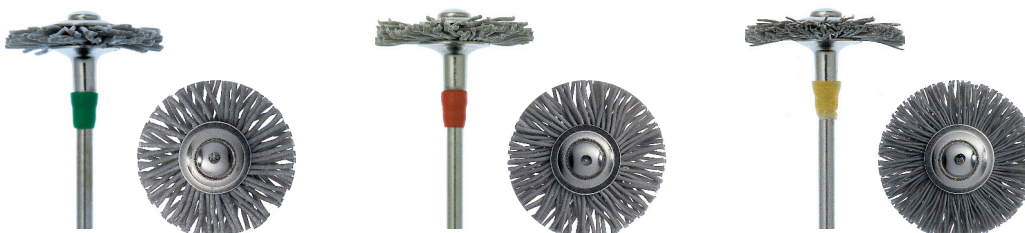

	210	210	210
Order-No	703HP	704HP	705HP
ISO shape	543	543	543
P	506	506	506
VE 	5	5	5
Step	3	4	5

Diaswiss Felt

Diamond-impregnated felt for ultimate high-shine.

Diaswiss Felt

Feutres diamantés pour un brillant ultime poli-glacé.

Diaswiss Felt

Diamantierte Filze für den ultimativen Hochglanz.

Diaswiss Felt

Filtros diamantados para un excelente pulido de alto brillo.

Diaswiss Felt

Feltrini diamantati per la brillantatura finale.

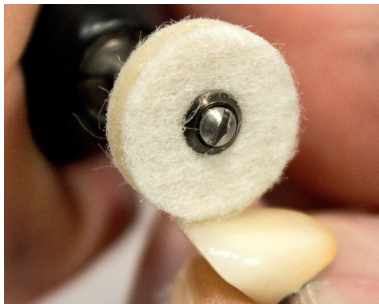

Diafelt

S: HP

Speed: 1'-3.000

L	3	3
D ø 1/10 mm	150	120
Order-No	710HP	711HP
ISO shape	372	372
P	507	507
VE 	10 + 1 mandrel	10 + 1 mandrel



Diagoat

Goat-hair brush for polishing of precious metals, composites and acrylics (polishing paste needed).

Diagoat

Brosse de polissage en poils de chèvre pour le polissage des alliages précieux, des composites et des résines. Pâte à polir nécessaire.

Diagoat

Polierbürste aus Ziegenhaar zum Polieren von Edelmetall, Kompositen und Kunststoffen. Polierpaste erforderlich.

Diagoat

Cepillos de pelo de cabra para pulir aleaciones preciosas, resinas compuestas y acrílicos protéticos. Imprescindible usar con pasta de pulir.

Diagoat

Spazzola in pelo di capra per la lucidatura di metalli nobili, compositi e resine. Necessario l'uso di pasta per lucidare.



Diagoat

S: HP

Speed: 5'-10.000

D ø 1/10 mm	150	190
Order-No	720HP	721HP
ISO shape	543	543
P	508	508
VE 	6	6



Model Preparation Kit

P: 510

S: **HP**

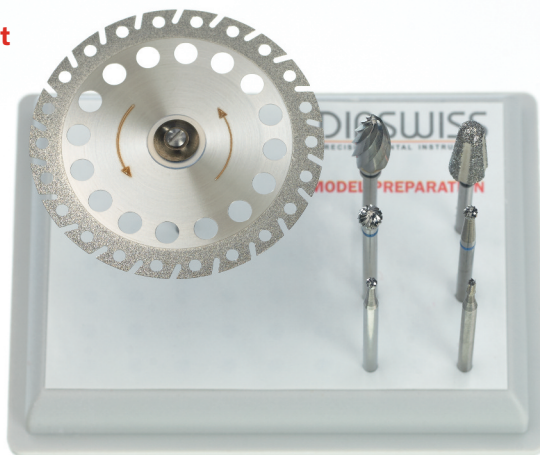

F	934	251	837	71	71	1	21
S	HP	HP	HP	HP	HP	HP	HP
∅	450	060	070	040	023	018	014
P	119	54	102	50	45	31	31

Order-No	104 934 450	1C251EG 060	104 SG 837 070	1CX 71G 040	1CX 71G 023	104 001 018	104 021 014
-----------------	-------------	-------------	----------------	-------------	-------------	-------------	-------------

Lithium disilicate / Zirconia Kit

P: 511

S: **HP**

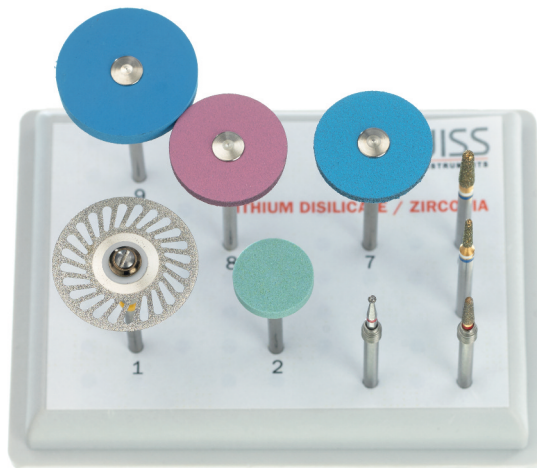

F	914	9507	801	856	847	850	551	561	671	
S	HP	HP	FG	FG	HP	HP	HP	HP	FG-HP	FG-HP
∅	220	110	014	021	016	025	180	180	220	

D			F	F							
P	19	401	1	4	13	14	501	501	501	95	95

Order-No	104SF914SP220	9507 G 110	314 F 801 014	314 FSG 856 021	104 Z 847 016	104 Z 850 025	551HP	561HP	671HP	1Reducer3	1Reducer3
-----------------	---------------	------------	---------------	-----------------	---------------	---------------	-------	-------	-------	-----------	-----------

Composite Kit

P: 512

S: **HP**



F	79	138	2	642	230	240	705	720	721	
S	HP	HP	FG	HP	HP	HP	HP	HP	HP	FG-HP
Ø	040	018	012	080	120	120	210	150	190	
P	43	42	31	503	74	74	506	508	508	95

Order-No	1SX 79UF 040	1SX 138UF 018	314 002 012	642UM	230HP	240HP	705HP	720HP	721HP	1Reducer3
-----------------	--------------	---------------	-------------	-------	-------	-------	-------	-------	-------	-----------

Acrylics Kit

P: 513

S: **HP**



F	251	251	79	251	138	3	21	21	2	1	640	650	705	721
S	HP	HP	HP	HP	HP	HP	HP	HP	HP	HP	HP	HP	HP	HP
Ø	060	060	040	060	016	023	014	012	016	006	120	120	210	190
P	51	53	47	43	46	41	31	31	31	31	501	501	506	508

Order-No	1C 251SG 060	1CX 251F 060	1CX 79F 040	1C 251F 060	1CX 138F 016	1CC 3 023	104 021 014	104 021R 012	104 002 016	104 001 006	640UM	650UM	705HP	721HP
-----------------	--------------	--------------	-------------	-------------	--------------	-----------	-------------	--------------	-------------	-------------	-------	-------	-------	-------

Precious alloys Kit

P: 514

S: **HP**



F	7001	78	79	487	77	138	33	23	600	610	721
S	HP	HP	HP	HP	HP	HP	HP	HP	HP	HP	HP
∅	220	060	045	023	023	018	016	010	220	220	190
P	121	53	54	50	50	42	31	31	502	502	508

Order-No

104 7001 220
1CX 78F 060
1CX 79SF 045
1CX 487SF 023
1CX 77SF 023
1CX 138UF 018
104 033R 016
104 023R 010
600HP
610HP
721HP

Non precious alloys Kit

P: 515

S: **HP**

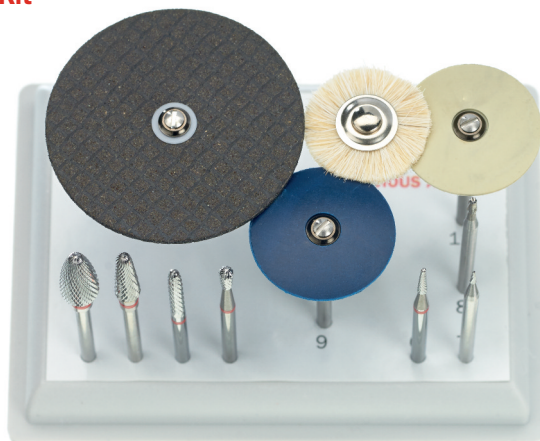

F	7003	78	79	487	77	138	23R	33R	600	610	721
S	HP	HP	HP	HP	HP	HP	HP	HP	HP	HP	HP
∅	400	060	040	023	023	016	010	016	220	220	190
P	122	53	47	47	46	46	31	31	502	502	508

Order-No

104 7003 400
1CX 78F 060
1CX 79F 040
1CX 487F 023
1CX 77F 023
1CX 138F 016
104 023R 010
104 033R 016
600HP
610HP
721HP

Ceramics Kit

P: 516

S: **HP**

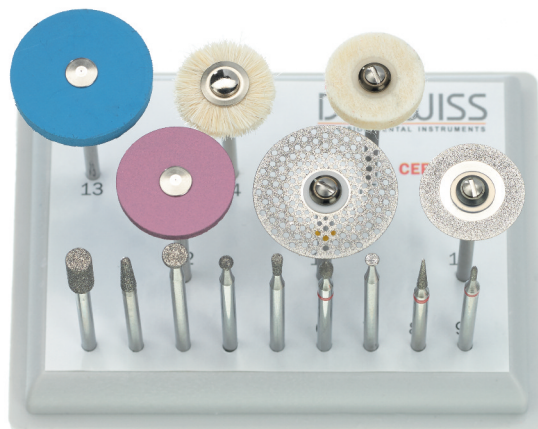

F	840	850	818	801	807	368	808	859	860	914	914	561	671	720	710
S	HP	HP	HP	HP	HP	HP	HP	HP	HP	HP	HP	HP	HP	HP	HP
∅	040	025	040	023	018	023	023	018	012	160	220	180	220	150	150
P	14	13	14	12	11	12	12	11	11	19	19	501	501	508	507
Order-No	104 840 040	104 850 025	104 818 040	104 801 023	104 807 018	104F 368 023	104 808 023	104F 859 018	104F 860 012	104SF 914 160	104SF914CT220	561HP	671HP	720HP	710HP

Partial framework / Stellite Kit

P: 517

S: **HP**



F	7003	950	139	79	74	138	581	591
S	HP	HP	HP	HP	HP	HP	HP	HP
∅	400	210	023	040	060	016	220	220
P	122	16	45	50	50	45	504	504
Order-No	104 7003 400	104SF 950 210	1CX 139G 023	1CX 79G 040	1CX 74G 060	1CX 138G 016	581LUM	591LUM

DIASWISS Superbright

Diamond polishing paste for high-shine polishing of all types of dental ceramics, especially full ceramics such as lithium disilicate or zirconia. Highly concentrated diamond content, to be used with goat hair brush, felt or similar.

Grit size: 3-5 µ, Content: 6 g

Order-No 90800
Price category 607



DIASWISS Superbright

Pâte à polir concentrée pour polissage final, haute brillance de tous types de céramiques dentaires, p. ex. disilicate de lithium ou zircon. Haute concentration de diamants, à utiliser avec une brosse de poils de chèvre, feutres ou similaires.

Grain : 3-5 µ, Contenu: 6 g

Référence 90800
Catégorie de prix 607

DIASWISS Superbright

Hochkonzentrierte Polierpaste zur finalen Hochglanzpolitur aller Arten von Dentalkeramik, insbesondere Vollkeramiken, z.B. Lithiumdisilikat oder Zirkondioxid. Zu verwenden mit kurzhaarigen Ziegenhaarbürsten, Filzen o.ä.

Körnung 3-5 µ, Inhalt: 6 g

Bestell-Nr. 90800
Preiskategorie 607

DIASWISS Superbright

Pasta para pulir altamente concentrada para el pulido final de alto brillo de todos los tipos de cerámica dental, especialmente cerámicas sin metal, por ejemplo disilicato de litio o dióxido de zirconio. Para utilizarse con cepillos de pelo de cabra de pelo corto, fieltros o similares.

Granulado: 3-5 µ, Contenido: 6 g

N.º de pedido 90800
Grupo de precio 607

DIASWISS Superbright

Pasta diamantata per la lucidatura - brillantatura di tutti i tipi di ceramiche, come anche per: disilicato di litio e ossido di zirconio. Uso: con spazzole pelo di capra - feltrini ecc ecc.

Grana: 3-5 µ, Contenuto: 6 gr

Nº di codice 90800
Gruppo prezzo 607

DIASWISS Powerpaste

Diamond polishing paste for high-shine polishing of all types of dental ceramics, especially full ceramics such as lithium disilicate or zirconia. Extremely high concentration of diamonds for superb polishing results.

Grit size: 3-5 µ, Content: 6 g

Order-No 90900
Price category 608



DIASWISS Powerpaste

Pâte à polir hautement concentrée pour polissage final, haute brillance de tous types de céramiques dentaires, p. ex. disilicate de lithium ou zircon. Très forte concentration de diamants.

Grain : 3-5 µ, Contenu: 6 g

Référence 90900
Groupe de prix 608

DIASWISS Powerpaste

Extrem hochkonzentrierte Polierpaste zur finalen Hochglanzpolitur aller Arten von Dentalkeramik, insbesondere Vollkeramiken, z.B. Lithiumdisilikat oder Zirkondioxid.

Körnung 3-5 µ, Inhalt: 6 g

Bestell-Nr. 90900
Preiskategorie 608

DIASWISS Powerpaste

Pasta para pulir extremadamente concentrada para el pulido final de alto brillo de todos los tipos de cerámica dental, especialmente cerámicas sin metal, por ejemplo disilicato de litio o dióxido de zirconio.

Granulado: 3-5 µ, Contenido: 6 g

N.º de pedido 90900
Grupo de precio 608

DIASWISS Powerpaste

Pasta diamantata estremamente concentrata per la lucidatura - brillantatura di tutti i tipi di ceramiche, come anche per: disilicato di litio e lo zirconio.

Grana: 3-5 µ, Contenuto: 6 gr

Nº di codice 90900
Gruppo prezzo 608

Polishing compound

Does not contain animal fat.
Super-finishing compound
for resins, CoCr, precious
alloys, titanium.
Content: 120 g



Order-No 90820
Price category 607



Pâte à polir

Ne contient pas de graisse animale. Pâte à polir haute brillance pour résines, CoCr, alliages précieux et titane.
Contenu: 120 g

Polierpaste

Frei von tierischen Fetten. Hochglanzpolierpaste für Kunststoffe, NE, Edelmetall, Titan.
Inhalt: 120 g

Pasta para pulir

Libre de grasas animales. Pasta para pulir de alto brillo para acrílicos, metales no preciosos, metales preciosos, titanio.
Contenido: 120 g

Pasta lucidante

Priva di grassi animali. Pasta brillantante per resina, leghe stelliti, leghe nobili e titanio.
Contenuto: 120 gr

Référence 90820
Catégorie de prix 607

Bestell-Nr. 90820
Preiskategorie 607

N.° de pedido 90820
Grupo de precio 607

N° di codice 90820
Gruppo prezzo 607

Diaspacer

Diaswiss die spacer is available in several colours and thicknesses. Excellent bonding, even coverage, scratch resistant with short drying time. Available in:

		Order no. P:		
blue	5µ	90010	600	
red	10µ	90020	600	
silver	13µ	90030	600	
gold	15µ	90040	600	
clear	3-5µ	90050	600	
thinner		90060	601	

Content: 25 ml

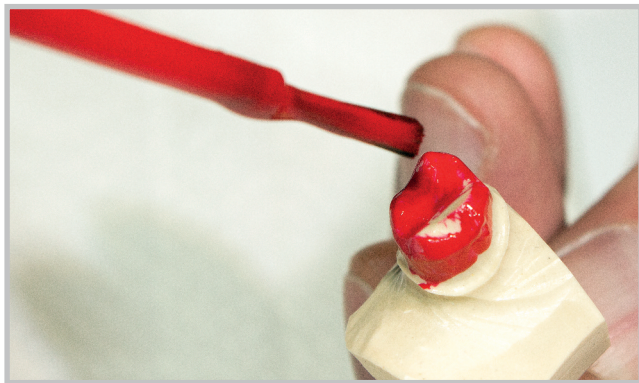

Diaspacer

Diaswiss die spacer est disponible en différentes couleurs et épaisseurs de couches. Excellent pouvoir couvrant uniforme, résistant aux rayures, temps de séchage court. Disponible en :

		Référence P		
Bleu	5µ	90010	600	
Rouge	10µ	90020	600	
Argent	13µ	90030	600	
Or	15µ	90040	600	
Clair	3-5µ	90050	600	
Diluant		90060	601	

Contenu de la bouteille: 25 ml

Diaspacer

Diaswiss Stumpflack ist in verschiedenen Farben und Schichtstärken erhältlich. Gut und gleichmäßig deckend, kratzfest, mit kurzer Trockenzeit. Erhältlich in:

		Best.-Nr. P		
Blau	5µ	90010	600	
Rot	10µ	90020	600	
Silber	13µ	90030	600	
Gold	15µ	90040	600	
Klar	3-5µ	90050	600	
Verdünner		90060	601	

Flascheninhalt: 25 ml

Diaspacer

La laca de muñones de Diaswiss está disponible en diferentes colores y espesores de capa. Cubre de forma óptima y uniforme, es resistente a los arañazos y su tiempo de secado es breve. La laca está disponible en:

		Num. ped. P		
Azul	5 µ	90010	600	
Rojo	10 µ	90020	600	
Plata	13 µ	90030	600	
Oro	15 µ	90040	600	
Claro	3-5 µ	90050	600	
Disolvente		90060	601	

Contenido de la botella: 25 ml

Diaspacer

La lacca per monconi è disponibile in diversi colori e spessori. Copertura ottima e uniforme, resistente all'abrasione, tempo di essiccazione breve. Disponibile in:

		Num. d'ordP		
Blu	5 µ	90010	600	
Rosso	10 µ	90020	600	
Argento	13 µ	90030	600	
Oro	15 µ	90040	600	
Trasparente	3-5 µ	90050	600	
Diluyente		90060	601	

Contenuto flacone: 25 ml

Diaswiss Debubblizer

The Diaswiss silicone and wax wetting agent helps you achieve exact bubble-free models of plaster or investment from silicone and other impression or duplicating materials. Not compatible with alignates and hydrocolloids. Evaporates without residue, short drying time. Avoid puddles. Content: 500 ml, with 125 ml pump spray bottle

Order-No 90200

Price category 603



Diaswiss Debubblizer

Ce détendeur de cire et de silicone permet la reproduction exacte et sans bulles des modèles en plâtre et en revêtement à partir de moulages en silicone, de gel de duplication et d'objets coulés. Ne convient pas pour les alginates et les hydrogels. Évaporation sans résidus, temps de séchage réduit. Éviter la formation de flaques.

Contenu: 500 ml, avec pulvérisateur à pompe 125 ml

Référence: 90200

Catégorie de prix: 603

Diaswiss Debubblizer

Dieser Silikon- und Wachsentspanner erlaubt die konturscharfe und blasenfreie Wiedergabe von Gips- und Einbettmassemodellen aus Silikonabdrücken, Dubliermaterial und Gussobjekten. Nicht geeignet für Alginate und Hydro-Gele. Rückstandsfree Verdunstung, kurze Trockenzeit. Pfützenbildung vermeiden.

Inhalt: 500 ml, mit 125 ml Pumpsprühflasche

Bestell-Nr. 90200

Preisgruppe: 603

Diaswiss Debubblizer

Este reductor de tensión para silicona y cera permite la reproducción sin burbujas y con contornos nítidos de los modelos de yeso y de revestimiento de impresiones de silicona, materiales de duplicación y objetos colados. No está indicado para alginatos ni hidrogeles. Volatilización sin residuos, tiempo de secado breve.

Evitar la formación de charcos. Contenido: 500 ml, con botella pulverizadora 125 ml

N.º de pedido 90200

Grupo de precio: 603

Diaswiss Debubblizer

Riduttore di tensione per silicone e cera, consente la riproduzione dai contorni definiti e senza soffiature di modelli di gesso e massa da rivestimento per impronte di silicone, materiale di duplicazione e oggetti di fusione. Non idoneo per alginati e idrogel. Evaporazione senza residui, tempi di essiccazione brevi.

Contenuto: 500 ml, con nebulizzatore 125 ml.

N° d'ordine 90200

Gruppo prezzo: 603

Diaswiss Silicone spray

Diaswiss Silicone spray separates plaster against plaster, acrylics, rubber, silicone, metals and wax.

Spray distance: 10 cm.

Content 75 ml.

Order no: 90100

Price category: 601



Diaswiss Silicone spray

Pulvérisation universelle pour séparer le plâtre du plâtre, du plastique, du caoutchouc, du métal et de la cire.

Distance de pulvérisation env. 10 cm.

Contenu 75 ml.

Référence: 90100

Catégorie de prix: 601

Diaswiss Silicone spray

Universell einsetzbarer Spray zum Separieren von Gips gegen Gips, Kunststoff, Gummi, Metall und Wachs.

Sprühentfernung ca. 10 cm.

Inhalt 75 ml.

Bestell-Nr. 90100

Preisgruppe: 601

Diaswiss Silicone spray

Spray de aplicación universal para separar yeso del yeso, acrílicos, goma, metal y cera.

Distancia de pulverización aprox. 10 cm.

Contenido 75 ml.

N.º de pedido 90100

Grupo de precio: 601

Diaswiss Silicone spray

Spray universale per la separazione del gesso da gesso, plastica, gomma, metallo e cera.

Distanza di nebulizzazione, circa 10 cm.

Contenuto 75 ml.

N° d'ordine 90100

Gruppo prezzo: 601

Diaswiss Adhesive spray

The Diaswiss adhesive spray is used to apply wax relief parts to the model when modeling partials. The spray leaves a very thin layer, wax relief parts stick and do not detach during the vibration of the investment. Modelations are enhanced as waxing of single parts is no longer necessary.

Spray distance: 10-15 cm.

Content: 75 ml.

Order-No **90300**

Price category **601**



Diaswiss Adhesive spray

Ce spray adhésif pour coulées de modèle est destiné à l'application d'éléments préfabriqués en cire dans la zone de coulée du modèle. La pulvérisation laisse une couche très fine, les pièces en cire pressées adhèrent de façon indissociable et ne se détachent pas lorsque le revêtement vibre. Les modèles sont plus graciles, étant donné qu'il n'est pas nécessaire d'enrober les pièces de cire.

Distance de pulvérisation:
10-15 cm.

Contenu: 75 ml.

Référence: **90300**

Catégorie de prix: **601**

Diaswiss Adhesive spray

Das Diaswiss Haftspray für Modellguss dient zur Applikation von Wachsfertigteilen im Modellguss. Der Spray hinterlässt eine sehr dünne Schicht, angedrückte Wachsteile haften unverrückbar und lösen sich nicht beim Einvibrieren der Einbettmasse. Modellationen werden graciler, da Teile nicht angewachst werden müssen.

Sprühdistanz: 10-15 cm.

Inhalt: 75 ml.

Bestell-Nr. **90300**

Preisgruppe: **601**

Diaswiss Adhesive spray

Este aerosol adhesivo para esqueléticos está indicado para la aplicación de componentes de cera fabricados en el área del esquelético. El aerosol forma una capa muy fina, los componentes presionados en ella se quedan firmemente adheridos y no se despegan durante la carga por vibración del revestimiento. De este modo se consiguen modelados más graciles porque no es necesario encerar los componentes.

Distancia de pulverización:
10-15 cm.

Contenido: 75 ml.

N.º de pedido **90300**

Grupo de precio: **601**

Diaswiss Adhesive spray

Spray adesivo per preformati in cera per la costruzione di scheletrati. Lascia dopo lo spruzzo una patina adesiva sul modello in rivestimento, che facilita l'applicazione dei preformati in cera. Brucia senza lasciare residui.

Distanza di nebulizzazione:
10-15 cm.

Contenuto: 75 ml.

N° d'ordine **90300**

Gruppo prezzo: **601**

Diaswiss Ceramspray

The Diaswiss Ceramspray is a silicone-free spray to separate ceramics against plaster. Residue-free as remains on the ceramics burn without leaving residue.

Spray distance 5-8 cm.

Content: 75 ml.

Order-No 90400

Price category 600



Diaswiss Ceramspray

Diaswiss Ceramspray est un spray de séparation sans silicone pour séparer la céramique du plâtre. Les restes demeurés sur la céramique brûlent sans laisser des résidus.

Distance de pulvérisation 5-8 cm

Contenu: 75 ml.

Référence: 90400

Catégorie de prix: 600

Diaswiss Ceramspray

Diaswiss Ceramspray ist ein silikonfreier Separierspray für Keramik gegen Gips. Rückstandsfrei, da auf der Keramik verbleibende Reste verbrennen.

Sprühentfernung 5-8 cm.

Inhalt: 75 ml.

Bestell-Nr: 90400

Preisgruppe: 600

Diaswiss Ceramspray

Diaswiss Ceramspray es un aerosol separador sin silicona para separar cerámica contra yeso. No deja residuos porque los restos sobre la cerámica se queman.

Distancia de pulverización 5-8 cm.

Contenido: 75 ml.

N.º de pedido: 90400

Grupo de precio: 600

Diaswiss Ceramspray

Diaswiss Ceramspray è uno spray senza silicone per isolare la ceramica dal gesso, brucia senza lasciare alcun residuo.

Distanza nebulizzazione 5-8 cm.

Contenuto: 75 ml.

N° d'ordine: 90400

Gruppo prezzo: 600

Diaswiss Occlusion spray

This extra-fine Diaswiss occlusion spray is available in several colours. The spray allows easy marking of contact points on prosthetic works and crowns. Easy to control, non-flammable, incl. tube nozzle. Easy to remove with brush or steam-jet. Insoluble in water or alcohol. Spray film thickness: 6 – 8 µ. Spray distance: 3-5 cm. Content: 75 ml.

	Order no	P
green	90510	604
red	90520	604
blue	90530	604
white	90540	604



Diaswiss Occlusion spray

Le spray d'occlusion très fin Diaswiss est disponible en plusieurs couleurs et sert à repérer les points de contact des travaux de prothèses et des couronnes. Facile à doser, ininflammable, avec buse ronde. S'enlève aisément au pinceau ou au jet de vapeur. Non soluble dans l'eau ou l'alcool. Épaisseur du film de pulvérisation: 6-8 µ. Distance de pulvérisation 3-5 cm. Contenu: 75 ml.

	Référence	P
Vert	90510	604
Rouge	90520	604
Bleu	90530	604
Blanc	90540	604

Diaswiss Occlusion spray

Das hochfeine Diaswiss Okklusionsspray ist in mehreren Farben erhältlich und dient zur Markierung der Kontaktpunkte prothetischer Arbeiten und Kronen. Leicht dosierbar, nicht brennbar, inkl. Rohrdüse. Mit dem Pinsel oder Dampfstrahler leicht zu entfernen. Nicht löslich in Wasser oder Alkohol. Sprühfilmdicke: 6 – 8 µ. Sprühentfernung 3-5 cm. Inhalt: 75 ml.

	Best.-Nr.	P
grün	90510	604
rot	90520	604
blau	90530	604
weiss	90540	604

Diaswiss Occlusion Spray

El spray de oclusión extrafino de Diaswiss está disponible en diferentes colores y se emplea para marcar los puntos de contacto de las prótesis y coronas. Fácil de dosificar, no inflamable, incl. boquilla de tubo. Remoción sencilla con pincel o chorro de vapor. No es soluble en agua ni en alcohol. Espesor de película: 6 – 8 µ. Distancia de pulverización 3-5 cm. Contenido: 75 ml.

	N.º de pedido	P
verde	90510	604
rojo	90520	604
azul	90530	604
blanco	90540	604

Diaswiss Occlusion spray

Il finissimo spray per occlusione Diaswiss è disponibile in diversi colori ed è impiegato per contrassegnare i punti di contatto di ponti e corone. Facile da dosare, non infiammabile, con ugello compreso. Semplice da rimuovere a pennello o vapore. Non solubile in acqua o alcool. Spessore della pellicola: 6 – 8 µ. Distanza di nebulizzazione 3-5 cm. Contenuto: 75 ml.

	N° d'ordine	P
verde	90510	604
rosso	90520	604
blu	90530	604
bianco	90540	604

Diascan spray

Diaswiss scanspray is an ultrafine spray for preparation of surfaces for CAD/CAM scanning and for friction testing on telescopic crowns and attachments. Can be easily removed with a brush, insoluble in water and alcohol. Do not expose to sunlight or temperatures above 50° C.

Content: 75 ml.

	Order no	P
white	90610	605
red	90620	605



Diascan spray

Diaswiss scanspray est un spray extrêmement fin pour la préparation de surfaces pour le scannage par CAD/CAM ainsi que pour l'essai de friction des couronnes coniques et télescopiques, barres et gouttières de toute sorte. S'enlève à sec, non soluble dans l'eau ou l'alcool. Protéger des rayons solaires ou du réchauffement à plus de 50°C.

Contenu: 75 ml.

Diascan spray

Diaswiss scanspray ist ein extrem feiner Spray zur Vorbereitung von Oberflächen zum CAD/CAM – Scanning sowie zur Friktionsprüfung von Konus- und Teleskopkronen, Riegeln und Geschieben aller Art. Trocken entfernbar, nicht löslich in Wasser oder Alkohol.

Vor Sonnenbestrahlung oder Erwärmung über 50° C schützen. Inhalt: 75 ml.

Diascan spray

El spray para escaneado de Diaswiss es un aerosol extremadamente fino indicado tanto para la preparación de las superficies para el escaneado CAD/CAM, como para la comprobación de la fricción de las coronas cónicas y telescópicas, barras y attaches de todo tipo. No es soluble en agua ni en alcohol.

Proteger de la radiación del sol y del calentamiento por encima de los 50 °C.

Contenido: 75 ml.

Diascan spray

Diaswiss scanspray è uno spray estremamente fine per la preparazione di superfici per la scansione con CAD/CAM, nonché per la prova di frizione di corone coniche e telescopiche, chiavistelli ed attacchi di tutti i tipi. Semplice da rimuovere, non solubile con acqua o alcool.

Proteggere dalle radiazioni solari e da temperature superiori a 50 °C.

Contenuto: 75 ml.

	Référence	P
Blanc	90610	605
Rouge	90620	605

	Best.-Nr.	P
weiss	90610	605
rot	90620	605

	N.° de pedido	P
blanco	90610	605
rojo	90620	605

	N° d'ordine	P
bianco	90610	605
rosso	90620	605

Bur blocks

sterilizable up to 135°C

24 pieces HP

Order no. Bur block HP 24

P: 90

48 pieces HP

Order no. Bur block HP 48

P: 91

72 pieces HP

Order no. Bur block HP 72

P: 92

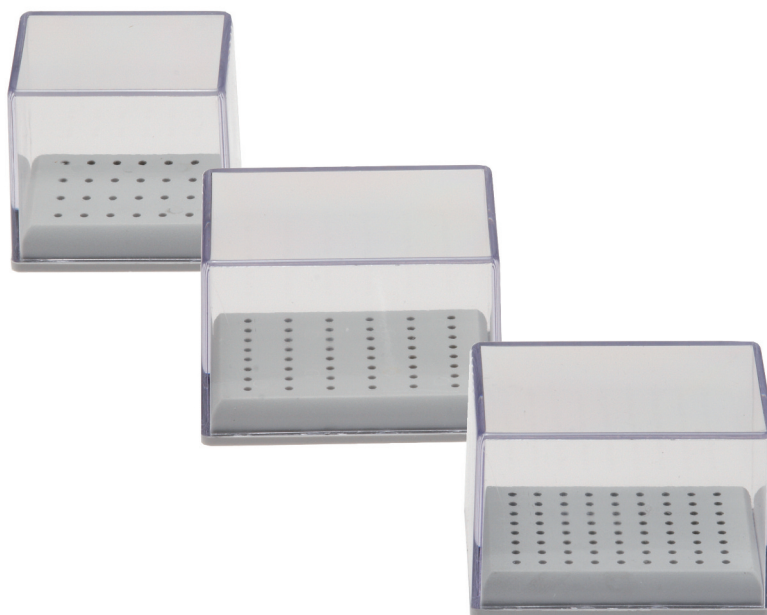

Porte-fraises

stérilisable à une température maxi de 135 °C

24 pièces PM

Référence Bur block HP 24

P: 90

48 pièces PM

Référence Bur block HP 48

P: 91

72 pièces PM

Référence Bur block HP 72

P: 92

Bohrerständer

sterilisierbar bis 135°C

24 Stück HST

Best.-Nr. Bur block HP 24

P: 90

48 Stück HST

Best.-Nr. Bur block HP 48

P: 91

72 Stück HST

Best.-Nr. Bur block HP 72

P: 92

Fresero Diaswiss

esterilizable hasta 135 °C

24 unidades PM

N.º de pedido Bur block HP 24

P: 90

48 unidades PM

N.º de pedido Bur block HP 48

P: 91

72 unidades PM

N.º de pedido Bur block HP 72

P: 92

Portafrese Diaswiss

sterilizzabile fino a 135°C

24 pezzi H.P.

Nº d'ordine Bur block HP 24

P: 90

48 pezzi H.P.

Nº d'ordine Bur block HP 48

P: 91

72 pezzi H.P.

Nº d'ordine Bur block HP 72

P: 92

Mandrels

Mandrins

Mandrelle

Mandriles

Mandrini

Mandrels



L	-	-	-	-	-	12	-	-
D \varnothing 1/10 mm	030	050	070	-	050	055	030	050
Order-No	4003HP	4005HP	4007HP	4008HP	4009HP	4020HP	2005RA	4030RA
P	96	96	97	98	97	97	32	32

Reducers

Réducteurs

Reduzierstücke

Reductores

Riduttori

Reducers

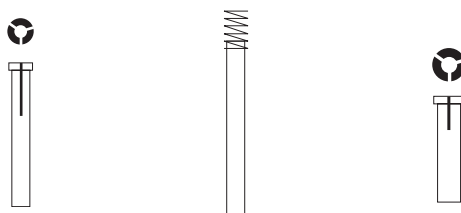

L	190	340	140
	FG - HP	FG - HP	2,35 -> 3
Order-No	Reducer1	Reducer3	Reducer5
P	93	95	95



Index Dentist

Adjustment kit.....59
 Bur blocks73
 Carbide burs.....44-55
 Crown cutter carbide54-55
 Diabrush ceram61
 Diacarb carbide burs44-55
 Diaceram 2-step58
 Diaceram 3-step59
 Diacleen.....74-75
 Diacomp60
 Diaflex mini33
 Diamond instruments8-38
 Diaprophy62
 Diasoft crown cutter33
 Diaswiss dentistry sets39-43
 Diaswiss Felt.....62
 DIAtaper71
 Diatemp.....61
 Diazircon crown cutter.....31
 Disinfection74-75
 Endodontic instruments.....69-72
 FG and RA diamonds12-29
 FG diamonds for zirconia/allceramics30
 FG diamonds microprep27
 FG diamonds reducers and depth markers26
 FG preparation tools with guide pin.....29
 FG turbo grinders.....25
 Finishing burs carbide52-53
 Orthodontic carbide bur.....55
 Perio diamond instruments28
 Pictograms76
 Polishers56-62
 Reducers73
 Surgical burs63-68
 Surgicut68
 Swiss Goldies.....34-38
 Trepanation instrument zirconia32
 Zirconia crown cutter32

Index Dental lab

Adhesive spray157
 Bur blocks161
 Carbide burs.....78-99
 Ceramspray158
 Debubblizer155
 Diabrush146
 Diaceram 2-step140
 Diaceram 3-step141
 Diacrown.....143
 Diacryl Pol144
 Diagoat147
 Diametal142
 Diamond discs118-128
 Diaspacer154
 Diaswiss Felt.....147
 Diatitan.....145
 Diatrim109
 Diazircon.....133
 HP diamonds100-109
 infiniti carbide burs90-91
 Mandrels162
 Milling technique95-99
 Occlusion spray159
 Pin Drill.....87
 Plaster discs128
 Poli-Max134-135
 Polishers139-147
 Polishing paste152-153
 Reducers162
 Scanspray160
 Separating discs129
 Silicon spray156
 Sintered diamond discs117
 Sintered diamonds110-117
 Tool kits148-151
 Turbo diamonds HP108
 Wire brush wheel109
 Zirconia tools130-138



Index cabinet dentaire

Adjustment kit.....	59
Coupe couronnes carbure.....	54-55
Coupe couronnes zircon.....	32
Désinfection.....	74-75
Diabrush ceram.....	61
Diacarb fraises carbure de tungstène.....	44-55
Diaceram 2-step.....	58
Diaceram 3-step.....	59
Diacleen.....	74-75
Diacomp.....	60
Diaflex mini.....	33
Diamants FG microprep.....	27
Diamants FG pour zircon/céramique sans métal.....	30
Diamants FG réducteurs et marqueurs de profondeur.....	26
Diaprophy.....	62
Diasoft coupe couronnes.....	33
Diaswiss Felt.....	62
Diaswiss sets cabinet.....	39-43
DIAtaper.....	71
Diatemp.....	61
Diazircon coupe couronnes.....	31
FG Turbo.....	25
Fraise orthodontique.....	55
Fraises carbure de tungstène.....	44-55
Fraises chirurgicales.....	63-68
Fraises de finition en carbure.....	52-53
Fraises diamantées FG et RA.....	12-29
Instruments diamantés.....	8-38
Instruments diamantés perio.....	28
Instruments endodontiques.....	69-72
Instruments pour trépaner zircon.....	32
Outils de préparation avec guide FG.....	29
Pictogrammes.....	76
Polissoirs.....	56-62
Porte-fraises.....	73
Réducteurs.....	73
Surgicut.....	68
Swiss Goldies.....	34-38

Index laboratoire

Brosse en acier diamanté.....	109
Ceramspray.....	158
Debubblizer.....	155
Diabrush.....	146
Diaceram 2-step.....	140
Diaceram 3-step.....	141
Diacrown.....	143
Diacryl Pol.....	144
Diagoat.....	147
Diametal.....	142
Diaspacer.....	154
Diaswiss Felt.....	147
Diatitan.....	145
Diatrim.....	109
Diazircon.....	133
Disques diamantés.....	118-128
Disques diamantés frittés.....	117
Disques pour plâtre.....	128
Disques pour tronçonner.....	129
Fraises diamantées avec spirale.....	108
Fraises en carbure de tungstène.....	78-99
Fraise pour pins.....	87
infiniti fraises carbure.....	90-91
Instruments diamantés frittés.....	110-117
Instruments diamantés PM.....	100-109
Instruments pour le zircon.....	130-138
Mandrins.....	162
Pâte à polir.....	152-153
Poli-Max.....	134-135
Polissoirs.....	139-147
Porte-fraises.....	161
Réducteurs.....	162
Scanspray.....	160
Silicon spray.....	156
Spray adhésif.....	157
Spray d'occlusion.....	159
Technique de fraisage.....	95-99
Tool kits.....	148-151



Index Zahnarzt

Adjustment kit.....	59
Bohrerstände.....	73
Chirurgische Instrumente.....	63-68
Diabrush ceram.....	61
Diacarb Hartmetallwerkzeuge.....	44-55
Diaceram 2-step.....	58
Diaceram 3-step.....	59
Diacleen.....	74-75
Diacomp.....	60
Diaflex mini.....	33
Diamantwerkzeuge.....	8-38
Diaprophy.....	62
Diasoft Kronentrenner.....	33
Diaswiss Felt.....	62
Diaswiss Sets Zahnmedizin.....	39-43
DIAtaper.....	71
Diatemp.....	61
Diazircon Kronentrenner.....	31
Endodontische Instrumente.....	69-72
FG und WST Diamanten.....	12-29
FG Diamanten für Zirkon/Vollkeramik.....	30
FG Diamanten Microprep.....	27
FG Diamanten Reduzierer und Tiefenmarkierer.....	26
FG Präparationswerkzeuge mit Führungspin.....	29
FG Turboschleifer.....	25
Hartmetallfinierer.....	52-53
Hartmetallwerkzeuge.....	44-55
KFO Entferner.....	55
Kronentrenner Hartmetall.....	54-55
Kronentrenner Zirkon.....	32
Perio Instrumente.....	28
Piktogramme.....	76
Polierer.....	56-62
Reduzierer.....	73
Reinigung und Desinfektion.....	74-75
Surgicut.....	68
Swiss Goldies.....	34-38
Trepanierinstrument Zirkon.....	32

Index Labor

Bearbeitungssets.....	148-151
Bohrerstände.....	161
Ceramspray.....	158
Debubblizer.....	155
Diabrush.....	146
Diaceram 2-step.....	140
Diaceram 3-step.....	141
Diacrown.....	143
Diacryl Pol.....	144
Diagoat.....	147
Diamantscheiben.....	118-128
Diametal.....	142
Diaspacer.....	154
Diaswiss Felt.....	147
Diatitan.....	145
Diatrim.....	109
Diazircon.....	133
Frästechnik.....	95-99
Galvanische Diamantwerkzeuge HST.....	100-109
Gipstrennscheiben.....	128
Haftspray.....	157
Hartmetallfräser.....	78-99
infiniti Hartmetallfräser.....	90-91
Mandrelle.....	162
Okklusionsspray.....	159
Pinbohrer.....	87
Polierer.....	139-147
Polierpaste.....	152-153
Poli-Max.....	134-135
Reduzierstücke.....	162
Scanspray.....	160
Silikonspray.....	156
Sinterdiamanten.....	110-117
Sinterdiamantscheiben.....	117
Stahldrahtbürste.....	109
Trennscheiben.....	129
Turbodiamanten mit Spirale.....	108
Zirkoninstrumente.....	130-138



Índice clínica dental

Adjustment kit.....	59
Cortador de coronas zirconio.....	32
Cortadores de corona en carburo de tungsteno.....	54-55
Desinfección.....	74-75
Diabrush ceram.....	61
Diacarb instrumentos de carburo de tungsteno.....	44-55
Diaceram 2-step.....	58
Diaceram 3-step.....	59
Diacleen.....	74-75
Diacomp.....	60
Diaflex mini.....	33
Diaprophy.....	62
Diasoft cortador de coronas.....	33
Diaswiss Felt.....	62
Diaswiss sets clínica dental.....	39-43
DIAtaper.....	71
Diatemp.....	61
Diazircon cortador de coronas.....	31
Fresas de carburo para acabado.....	52-53
Fresas diamantadas FG y CA.....	12-29
Fresas diamantadas FG con espiral.....	25
Fresas diamantadas FG con guía.....	29
Fresas diamantadas FG microprep.....	27
Fresas diamantadas FG para zirconia/cerámica sin metal.....	30
Fresas diamantadas FG reductores y marcadores de profundidad.....	26
Freseros.....	73
Instrumento para trepanación de circonio.....	32
Instrumentos de carburo de tungsteno.....	44-55
Instrumentos de endodoncia.....	69-72
Instrumentos diamantados.....	8-38
Instrumentos diamantados perio.....	28
Instrumentos quirúrgicos.....	63-68
Pictogramas.....	76
Pulidores.....	56-62
Reductores.....	73
Removedor de ortodoncia.....	55
Surgicut.....	68
Swiss Goldies.....	34-38

Índice laboratorio dental

Broca de pin.....	87
Cepillo de alambre de acero diamantado.....	109
Ceramspray.....	158
Debubblizer.....	155
Diabrush.....	146
Diaceram 2-step.....	140
Diaceram 3-step.....	141
Diacrown.....	143
Diacryl Pol.....	144
Diagoat.....	147
Diametal.....	142
Diaspacer.....	154
Diaswiss Felt.....	147
Diatitan.....	145
Diatrim.....	109
Diazircon.....	133
Discos de diamante.....	118-128
Discos de diamante macizo.....	117
Discos de separación.....	129
Discos diamantados para yeso.....	128
Fresas de carburo de tungsteno.....	78-99
Fresas diamantadas con espiral.....	108
Freseros.....	161
Infiniti fresas de carburo de tungsteno.....	90-91
Instrumentos de diamante galvánicos PM.....	100-109
Instrumentos de diamante macizo.....	110-117
Instrumentos para zirconio.....	130-138
Mandriles.....	162
Occlusion spray.....	159
Pasta para pulir.....	152-153
Poli-Max.....	134-135
Pulidores.....	139-147
Reductores.....	162
Scanspray.....	160
Sets de elaboración.....	148-151
Silicon spray.....	156
Spray adhesivo.....	157
Técnica de fresado.....	95-99







Indice studio

Adjustment kit.....	59
Diabrush ceram.....	61
Diacarb strumenti in carburo di tungsteno.....	44-55
Diaceram 2-step.....	58
Diaceram 3-step.....	59
Diacleen.....	74-75
Diacomp.....	60
Diaflex mini.....	33
Diaphophy.....	62
Diasoft tagliacorone.....	33
Diaswiss Felt.....	62
Diaswiss sets studio.....	39-43
DIAtaper.....	71
Diatemp.....	61
Diazircon tagliacorone.....	31
Disinfezione.....	74-75
Fresa per rimuovere i lavori di ortodonzia.....	55
Frese diamantate FG e CA.....	12-29
Frese diamantate FG con punta di riferimento.....	29
Frese diamantate FG microprep.....	27
Frese diamantate FG per zirconio/ceramica integrale.....	30
Frese diamantate perio.....	28
Frese dimantate FG a spirale.....	25
Frese in carburo di tungsteno per la finitura.....	52-53
Gommini.....	56-62
Pittogramme.....	76
Portafrese.....	73
Riduttori.....	73
Riduttori e incisori di profondità FG.....	26
Strumenti canalari ENDO.....	69-72
Strumenti chirurgici.....	63-68
Strumenti diamantati.....	8-38
Strumenti in carburo di tungsteno.....	44-55
Strumento per trepanare zirconio.....	32
Surgicut.....	68
Swiss Goldies.....	34-38
Tagliacorone in carburo di tungsteno.....	54-55
Tagliacorone zirconio.....	32

Indice laboratorio

Adhesive spray.....	157
Ceramspray.....	158
Debubblizer.....	155
Diabrush.....	146
Diaceram 2-step.....	140
Diaceram 3-step.....	141
Diacrown.....	143
Diacryl Pol.....	144
Diagoat.....	147
Diametal.....	142
Diaspacer.....	154
Diaswiss Felt.....	147
Diatitan.....	145
Diatrim.....	109
Diazircon.....	133
Dischi diamantati.....	118-128
Dischi diamantati per gesso.....	128
Dischi diamantati sinterizzati.....	117
Dischi separatori.....	129
Fresa fora gessi.....	87
Frese diamantate a spirale.....	108
Frese in carburo di tungsteno.....	78-99
Gommini.....	139-147
infiniti frese in carburo di tungsteno.....	90-91
Mandrini.....	162
Occlusion spray.....	159
Pasta per lucidatura.....	152-153
Poli-Max.....	134-135
Portafrese.....	161
Riduttori.....	162
Scanspray.....	160
Silicon spray.....	156
Spazzola in metallo diamantata.....	109
Strumenti diamantati galvanizzati H.P.....	100-109
Strumenti diamantati sinterizzati.....	110-117
Strumenti per zirconio.....	130-138
Tecnica de fresaggio.....	95-99
Tool kits.....	148-151

-  Diamond instruments | Carbide instruments | Polishers | Consumables | Endodontic instruments
-  Instruments diamantés | Fraises en carbure | Polissoirs | Consommables | Instruments endodontiques
-  Diamantwerkzeuge | Hartmetallinstrumente | Polierer | Verbrauchsartikel | Endodontische Instrumente
-  Instrumentos diamantados | Fresas en carburo de tungsteno | Pulidores | Consumibles | Instrumentos de endodoncia
-  Strumenti diamantati | Frese in carburo di tungsteno | Gommini | Articoli di consumo | Strumenti canalari ENDO

DIASWISS
PRECISION DENTAL INSTRUMENTS

Tel: +41 22 301 56 00
Fax: +41 22 301 56 50

mail@diaswiss.ch
www.diaswiss.ch